

# 弹指之间

Since 1991



1991



1996



2002



# 序 Introduction



在笔者从事吉他教学工作及参与各类型吉他讲座中，最常被询问到的问题便是——如何突破弹吉他的瓶颈？所以在这本书的开头，笔者就个人经验来和大家谈谈这个问题。

- 一、 舍弃会让人偷懒的移调夹(Capo)：Capo 的使用固然可以让歌曲弹奏简化，但是太过简易的弹奏，却是阻碍技巧进步的最大原因。所以笔者建议大家多弹弹其他的调性，尝试另一种方式的诠释。
- 二、 工欲善其事，必先利其器：可能在你弹奏多年的吉他后却惊讶地发现，阻碍你进步的竟然是你的吉他。所以在你进步的同时，你可能需要选择一把适合你弹奏的吉他。好吉他除了能让你得到好音色外，更重要的是好弹，至少不会虐待你的手指头！但是，当然的，好吉他的造价通常也比较昂贵。
- 三、 不要疏于音阶的练习：任何技巧的根基必定在于手指的灵活度，而这点却是许多民谣吉他手所欠缺的，不要排斥任何音阶的练习，这么一来才能活用吉他。
- 四、 熟悉乐理知识：学习乐理除了能充实自己的音乐知识外，更重要的是，要能大胆地使用和弦及音阶，这样才不会造成学了一大堆却不会活用的窘境。
- 五、 多抓歌，让自己的教材不至于匮乏：我认为，抓歌是进步的最大利器，因为抓歌可以偷偷学习到别人的吉他弹奏技巧及编曲方式。如果你有七分的模仿力，再加上三分的创造力，那就太完美了。

写到这里，我想每个人所遇到的瓶颈都不同，有的人可能还停留在四个和弦（C、Am、Dm、G7），有的人则是找不到喜欢的教材。不过，无论如何，笔者都希望这本书能够让各位朋友对民谣吉他的弹奏有一个通盘的了解，进而对突破瓶颈有些许的帮助。

本书的出版要感谢麦书国际文化事业有限公司的各位同仁，运用电脑排版，突破传统的谱面设计，给人耳目一新的感觉。更感谢各校吉他相关社团老师及学生们，及各位读者们的支持，谢谢大家！

潘尚文 1999.10

屈指一数，从笔者的第一本著作“音乐精灵”一直到本书“弹指之间”，算一算已经迈向第十个年头了，在从事著书及教学的这几年当中，笔者深深感觉到国内吉他音乐的起伏与变迁。就如同经过了校园民歌到现在的流行歌曲：从过去的类比式录音到现在的数位化录音：从一个人唱歌的民歌西餐厅到现在以乐团为主的 PUB；从以前弹 Jim Croce 到现在乏人问津，个中滋味，点滴在心头。时代在变，音乐在变，也意味着教材也需要改变。所以在这一次的修订版次中，笔者也大幅修改了弹指之间的部分内容，特别是在歌曲的应用上，相信更能符合弹奏者的实际需要。

在这本书里，个人以多年的吉他弹奏经历及从事专业音乐相关工作的经验，例举了许许多多流行歌曲的吉他弹奏方法，几乎已经涵盖了传统的基本技巧以及现在流行的特殊技巧，60篇循序渐进的单元内容与近500页的技巧练习，相信足以带领您进入吉他的音乐世界。首先，在内容上，我将繁杂的文章删去，增加了许许多多的图片说明，笔者深信简单而又扎实的文章，才是对琴友们最有助益的。其次，在技巧的取材上，我在本书曲例的空白处，整理了一些手指与乐句的练习范例，我称它叫“练功房”，这些都是你平常该练习的技巧。你可以把它当做暖指练习或是边看电视边做练习，都可以，其实是很生活化的东西，但是对你又非常的有帮助。最后在选曲上，除了大家较熟悉的国语流行歌曲外，另外再加上一些经典的西洋歌曲，配合技巧的解说做适度的编排。另外，对于很多琴友们的一致困扰，那便是书中会有很多的西洋歌曲没听过，而阻碍了学习，关于这一点，笔者建议各位花点时间去找朋友借借看，或者到唱片行去买音乐带回来听，因为既然收录在书中，必定是对弹奏技巧上有相当的帮助。再者，由于现代民谣吉他技巧，已融入了有关电吉他与古典吉他的特殊技巧，这点也是要请琴友们多加揣摩的，尤其是在某些电吉他技巧经过改编成民谣吉他弹奏的曲子上，更需要配合音乐带来练习，总之，多听、多唱、多写、多弹，是学好民谣吉他的不二法门。

此刻，有句朗朗上口广告词是这么说的「品客一口口，片刻不离手」，就如同本书一样，我正试着在撰写一本能够浅显易懂，没有太多艰深且多余的文字，最好能够让你依样就可以划葫芦，完完全全可以自学的吉他教材。至今，虽然还不能完全确定我是不是已经做到了，但我确有这样的使命感与目标。当你在使用本书时，期待你也能感受到此项的特色。最后，诚心的希望这本“弹指之间”，在各位学习的路上是您永远的老师，也衷心希望各位因为研读此书，而能够对于突破瓶颈有些许的帮助，那将是笔者最感到快乐的事了！ 祝福各位。

# 吉它 目录

1. 吉他的分类.....	8
2. 吉他各部名称.....	9
3. 选购吉他DIY.....	10
4. 吉他弹奏姿势.....	12
5. 本书使用符号与技巧解说.....	15
6. 基础乐理.....	18
7. 简谱.....	20
生日快乐歌	
Love Me Tender	
太湖船	
8. 如何使用PICK来弹奏.....	26
9. 强化左右手的速度.....	28
10. 如何换弦.....	29
11. 如何调音.....	30
12. 和弦.....	32
13. 15个初学者必学和弦.....	34
14. 和弦转换.....	36
15. 六线套谱上的指法与节奏.....	38
16. 音乐类型【一】慢灵魂乐 Slow Soul(8Beat).....	40
拥抱.....	41
至少还有你.....	44
被动.....	46
爱你一万年.....	48
17. 音乐类型【二】民谣摇滚 Folk Rock.....	50
静止.....	51
花心.....	54
分享.....	56

19. 复合和弦 Polychord.....	62
朋友.....	64
身边.....	66
约定.....	70
20. 音乐类型【四】慢摇滚 Slow Rock.....	74
浪人情歌.....	75
新不了情.....	78
痛哭的人.....	80
21. 音乐类型【五】灵魂乐 Soul(16Beat).....	83
分手吧.....	84
可以爱你真好.....	87
22. 音乐类型【六】跑马式的节奏.....	90
旷野寄情.....	91
凡人歌.....	94
23. 根音与经过音的变化与填充.....	96
对面的女孩看过来.....	98
24. 三和弦与七和弦的组成.....	102
25. 左右手的技巧【一】槌音、勾音、滑音与推音.....	106
Vincent.....	108
26. 音乐类型【七】三指法.....	112
还是会寂寞.....	114
外面的世界.....	117
27. 移调及移调夹的使用.....	120
28. 封闭和弦 Barre Chord.....	122
挪威的森林.....	127
征服.....	130
温柔.....	132
你要的爱.....	134
29. 出神入化的PICK弹奏.....	137
30. 大调音阶与小调音阶.....	139
自由.....	143
志明与春娇.....	147
31. 双音.....	151
To Be With You.....	153
一开始就没退路.....	157
32. 和弦动音线 Line Cliches.....	164
IF.....	166
解脱.....	169
爱我别走.....	173
秘密.....	177
33. 级数与顺阶和弦 Diatonic Chord.....	180
因为.....	182
如果有一天.....	187
开始懂了.....	191



34. 简易吉他编曲.....	194
爱情酿的酒.....	197
用心良苦.....	199
好不好.....	201
龙卷风.....	205
与你到永久.....	208
在凌晨.....	211
Wonderful Tonight.....	215
原来你什么都不想要.....	219
35. 右手的技巧【二】打板.....	222
写一首歌.....	223
More Than Words.....	228
星晴.....	233
36. 音感的培养.....	237
37. 节奏感的培养.....	238
38. 漫谈抓歌技巧.....	239
39. 简化和弦.....	243
Lemon Tree.....	245
想太多.....	250
40. 左右手的技巧【三】切音与闷音.....	256
情非得已.....	257
当我开始偷偷地想你.....	263
水蓝色眼泪.....	267
41. 复根音的伴奏方式.....	270
New York's Not My Home.....	272
I Have To Say I Love You In A Song.....	275
42. 五度圈.....	282
43. 转调.....	284
爱的初体验.....	287
Tears In Heaven.....	291
44. 左右手的技巧【四】泛音.....	295
45. 音乐类型【八】Bossa Nova.....	297
她的眼泪.....	299
46. 增减和弦 Diminished & Augmented.....	304
普通朋友.....	306
国王的新歌.....	310
47. 双吉他的伴奏.....	314
双手的温柔.....	317
Now And Forever.....	320
Hotel California.....	324
小小的太阳.....	331
48. 和弦的外音修饰.....	334
梦一场.....	336
她他.....	340
我可以抱你吗.....	345

一个人万岁.....	348
她来听我的演唱会.....	351
<b>49. 和弦的连接与经过和弦.....</b>	<b>354</b>
离人.....	357
<b>50. 代理和弦.....</b>	<b>361</b>
<b>51. 浅谈唱片制作.....</b>	<b>364</b>
剪爱.....	368
听海.....	372
光辉岁月.....	376
能不能不要说.....	380
有没有一首歌会让你想起我.....	385
开不了口.....	389
简单爱.....	393
爱的就是你.....	397
It's Just Love.....	401
未来人.....	406
<b>52. 二重唱.....</b>	<b>411</b>
无情的情书.....	414
大海.....	417
屋顶.....	419
广岛之恋.....	424
<b>53. Finger Style演奏曲.....</b>	<b>428</b>
Romance.....	429
Can You Feel The Love Tonight.....	431
玫瑰玫瑰我爱你.....	433
<b>54. 特殊调弦法.....</b>	<b>436</b>
明天我要嫁给你.....	438
Longer.....	441
<b>55. Slide / Bottleneck.....</b>	<b>445</b>
Dear.....	448
<b>56. 音乐类型 (+) 十二小节式的蓝调伴奏模式.....</b>	<b>454</b>
<b>57. 蓝调音阶.....</b>	<b>456</b>
<b>58. 琴弦整平.....</b>	<b>457</b>
<b>59. 各级和弦图表.....</b>	<b>458</b>
<b>60. 各调音阶图解.....</b>	<b>460</b>

# Guitar 1 吉他的分类



电吉他  
Electric Guitar

在琴身上配置电子拾音器 (Pick-ups) 扩音装置，多半在节奏性强、较现代之热门歌曲中来演奏。



古典吉他  
Classic Guitar

多使用于古典音乐与佛拉明哥 (Flamenco) 等类型之音乐中。



民谣吉他  
Folk Guitar

多使用于民谣歌曲、摇滚乐、蓝调音乐、爵士音乐等型态之音乐中，俗称为“空心木吉他”。



# Guitar 2 吉他各部名称

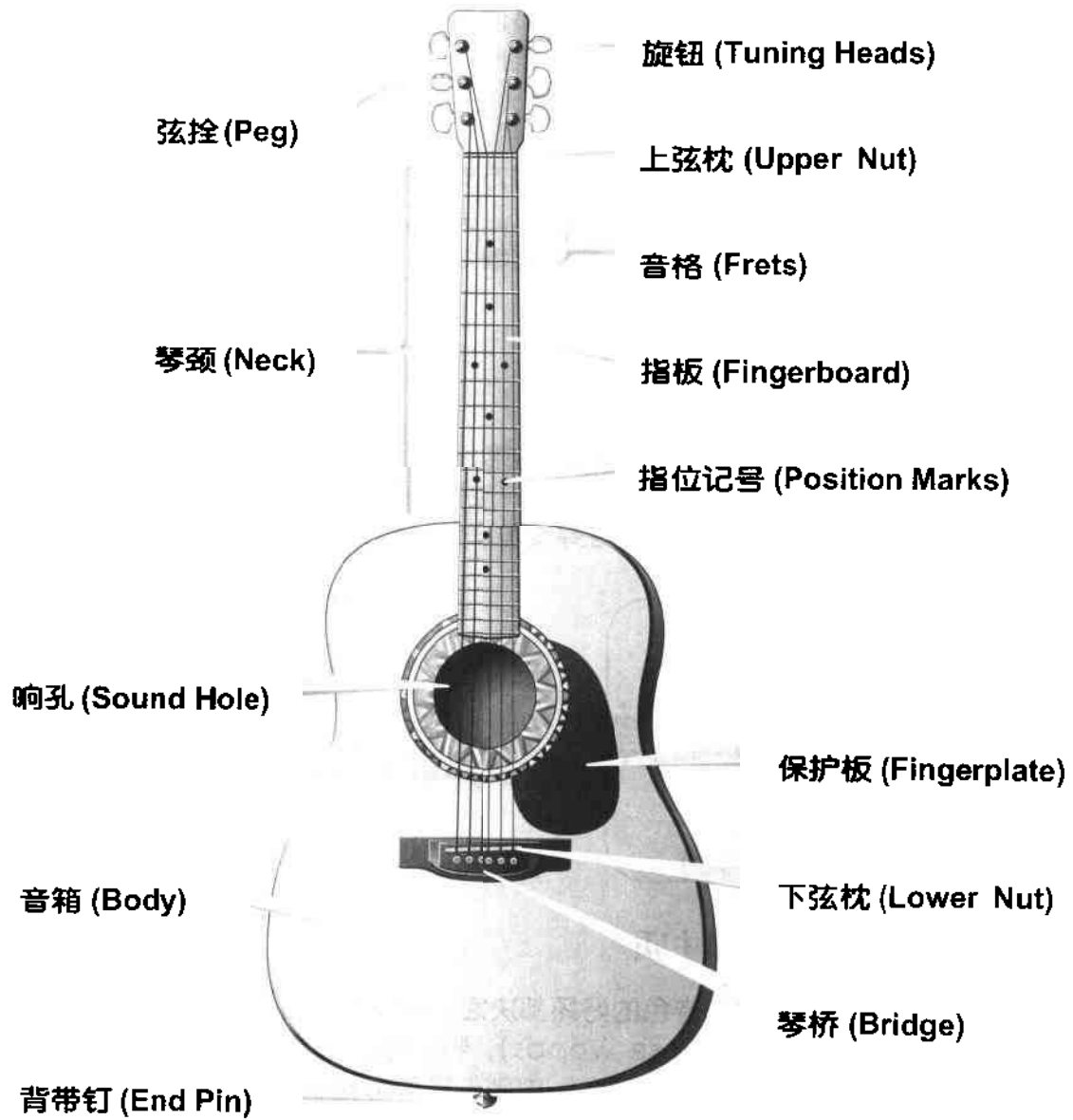



### 三、检视涂装部份

因为吉他喷了油漆之后增加了厚度，而导致音色的改变，这是在涂装工作上经常发生的事。不均匀的漆也容易造成共鸣的偏差，所以在购买时，涂装的均匀度会成为我们参考的一个重点，特别是在面板与侧底板的部份。

### 四、是否装置可调式钢管

一般只要是在中价位以上的吉他，在琴颈内都会装置有可调式钢管，当琴颈受到环境气候的改变而受潮弯曲时，可以适度的调整钢管使之复原，尤其是在潮湿的地区，是否装置钢管是蛮重要的选择依据。调整琴颈可使用六角板手在音孔内的琴颈末端螺丝孔处来做调整（有些吉他是在琴颈上方）。



### 五、弦高是否恰当

弦高是指当弦上紧之后与指板间的距离，一般来说，民谣吉他的弦高以 0.2 ~ 0.25 cm 最为恰当，如果弦高太高会使你的左手压弦变得困难，影响弹奏上的乐趣。然而太低的弦高则容易使弦因振动而碰触琴弦，产生吱吱的杂音，一般称为“打弦”，所以在选购时务必每一弦每一格测试，排除以上的问题。

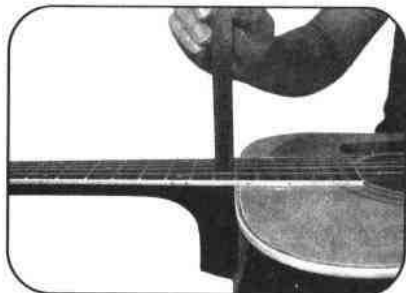

# Guitar 4 吉他弹奏姿势

正确的姿势，才能奏出好听的琴音，加速琴艺的进步。下图所示均为正确姿势，请选择适合自己的方式。

## 一、坐的方法



【一】  
右脚跷在左脚上，音箱凹部放在右腿上；也可以左脚跷在右腿上。此为古典吉他常用的姿势。



【二】  
浅坐在椅子上，稍把两腿放开，音箱凹部放右腿，此法适合身高比较矮及手比较短的人。

## 二、站的方法：



【三】  
使用吊带 (Strap) 挂在左肩上以安定琴身。此为民谣吉他演唱时，最常用的姿势。



【四】  
使用椅子辅助，把音箱凹部放于右腿。此亦为民谣吉他演唱时，另一种站的方法。



### 三、左手的姿势

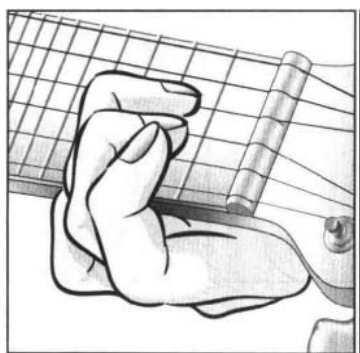

(1) 按弦尽量使指尖与弦垂直。

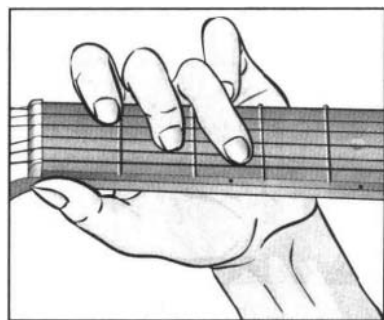

(2) 按弦以靠近琴格下方为佳，可使弹奏更为省力。

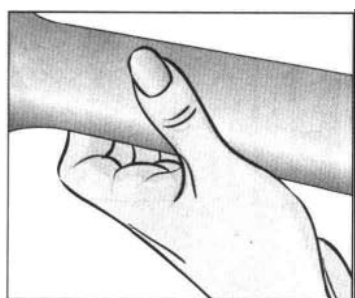

(3) 左手拇指置于琴颈中央，切勿扣住琴颈。

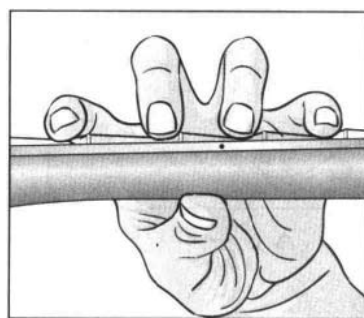

(4) 四只手指依序压在其主要负责之琴格上。



## 四、右手的姿势

### 1. 指法

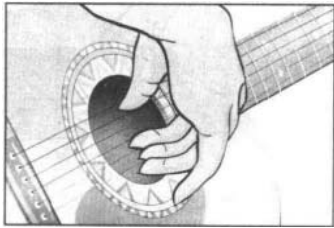

(A) 一般弹奏方式

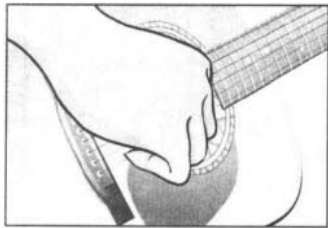

(B) 闷音弹奏方式



(C) 小指靠在琴上的弹奏

### 2. 使用 Pick 弹奏

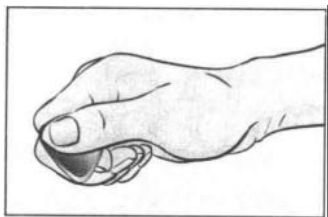

(A) 一般握法

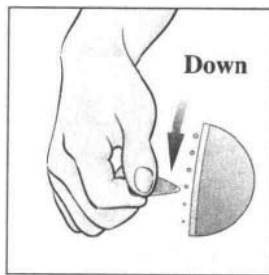

(B) 向下击弦

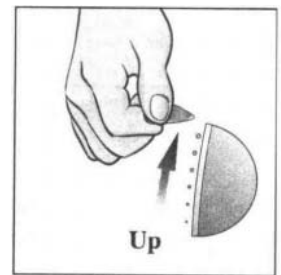

(C) 向上挑弦



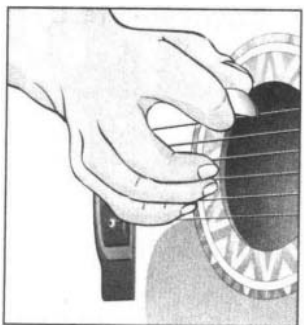





### 3. 综合弹奏



※使用Pick与手指的综合弹奏



# 5 Guitar 本书使用符号与技巧解说

 <p><b>Key</b> 原曲调号。在本书中均记录唱片原曲的原调。</p>	 <p><b>Rhythm</b> 歌曲音乐中的节奏形态。</p>
 <p><b>Play</b> 弹奏调号。即表示本曲使用此调来弹奏。</p>	 <p><b>Picking</b> 刷 Chord 的弹奏形态。</p>
 <p><b>Capo</b> 移调夹所夹的琴格数。</p>	 <p><b>Fingers</b> 歌曲弹奏时所使用的指法。</p>
 <p><b>Tempo</b> 节奏速度。(♩=N) 表示歌曲弹奏速度为每分钟 N 拍。</p>	 <p><b>Tune</b> 调弦法。</p>

常见范例:

<p><b>Key : E</b> <b>Play : D</b> <b>Capo : 2</b> <b>Rhythm : Slow Soul</b> <b>Tempo : 4/4 ♩=72</b></p>	<p>左例中表示歌曲为 E 大调, 但有时我们考虑弹奏的方便及技巧的使用, 可使用别的调来弹奏。好, 如果我们使用 D 大调来弹奏, 将移调夹夹在第 2 格, 可得与原曲一样之 E 大调, 此时歌曲弹奏速度为每分钟 72 拍。弹奏的节奏为 Slow Soul。</p>
---	--

常见谱上记号:

- ⋮ : 小节线。
- || : 乐句线, 通常我们以 4 小节或 8 小节称之。
- ||: : Repeat, 反覆弹唱记号。
- DC : Da Capo, 从头弹起。
- ※ 或 DS : Da Seqnue, 从另一个处再※弹一次。
- DC.N/R : D.C. No/Repeat, 从头弹起, 遇反覆记号则不须反覆弹奏。
- ※ N/R : ※ No/Repeat, 从另一个※处再弹一次, 遇反覆记号则不须反覆弹奏。
- ⊕ : Coda, 跳至下一个 Coda 弹奏至结束。
- Fine : 结束弹奏记号。
- Rit .... : Ritardando, 指速度渐次徐缓地渐慢。
- F.O. : Fade Out, 声音逐渐消失。
- Ad-lib. : 即兴创意演奏。



乐谱范例：

	1	2	3	4	
※				— 1. —	
:	5	6	7	8-1	:
				— 2. —	
	8-2		9	10	11
⊕		12		13	14
				※	
⊕		15		16	17
					18
					Fine

在采谱制谱过程中，为了要节省视谱的时间及缩短版面大小，我们将使用一些特殊符号来连接每一个乐句。在上例中，是一个比较常见之歌曲进行模式，歌曲中1至4小节为前奏，第5小节出现一反覆记号，但我们必须找到下一个反覆记号来做反覆弹奏，所以当我们弹奏至8-1小节时，须接回第八小节继续弹奏。但有时反覆弹奏时，旋律会不一样，所以我们就把不一样的地方另外写出来，如8-2小节；并在小节的上方标示出弹奏的顺序。

歌曲中9至12小节为副歌，13到14小节为间奏，在第14小节乐句线下可看到※记号，此时我们就寻找另一个※记号来做反覆弹奏，如果在※记号后没有特别注明No/Repeat，那我们将再把第一遍歌曲中，有反覆的地方再弹一次，直到出现有⊕记号。

最后，我们就往下寻找另一个⊕记号演奏至Fine结束。

有时我们会将歌曲的最后一小节写在⊕的第1小节，如上之12小节和15小节，这样做更能清楚看出歌与尾奏间的衔接情况。

演奏顺序： 1→4    5→8-1    5→7→8-2    9→14
5→8-1    5→7→8-2    9→11    15→18



弹指之间



## 各类乐器简写对照

钢琴	PN.
电钢琴	EPN.
空心吉他	AGT.
电吉他	EGT.
古典吉他	CGT.
分散和弦	Arp.
弦乐	Strings
小提琴	Vol.
电子琴	Organ
魔音琴/合成乐器	Syn.
萨克斯风	Sax.
歌声	Vo.
鼓	Dr.
电贝士	Bs.
长笛	Fl.
口白	Os.
小喇叭	Tp.

看谱是你进入音乐世界的第一步，了解乐谱上的各项演奏资讯，有助于你弹奏出更正确乐曲，你学到的将不仅是弹吉他而已。



# Guitar 6 基础乐理

## 一、音阶 (Scale)

在谱上以任何一音为基础，按照音程的顺序排列若干的阶级，至其高或低八度音为止，即成一音阶。

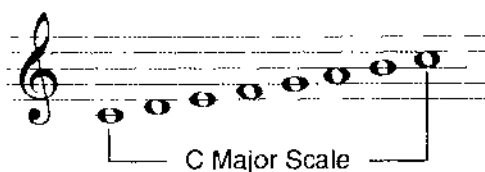

## 二、最常见的音阶种类

大调音阶 (Major Scale)

小调音阶 (Minor Scale)

自然小调音阶	Natural Minor Scale
和声小调音阶	Harmonic Minor Scale
旋律上行小调音阶	Ascending Melodic Minor Scale
旋律下行小调音阶	Descending Melodic Minor Scale

## 三、音阶与音级

音名	<b>C</b>	<b>D</b>	<b>E</b>	<b>F</b>	<b>G</b>	<b>A</b>	<b>B</b>	<b>C</b>
唱名	Do	Re	Mi	Fa	Sol	La	Si	Do
简谱记号	1	2	3	4	5	6	7	1̇
音级	I	II	III	IV	V	VI	VII	I
属名	主音	上主音	中音	下属音	属音	下中音	导音	主音



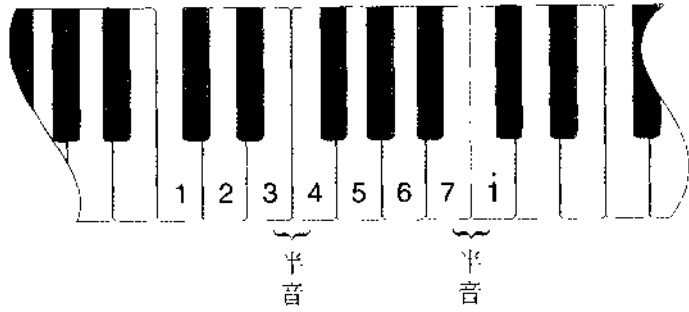

#### 四、C大调音阶 (C Major Scale)

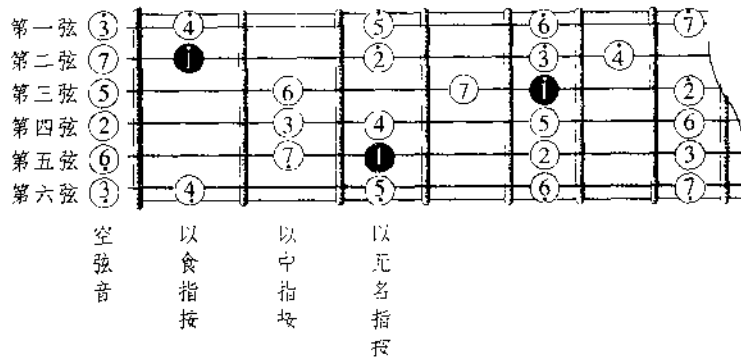

【注】 1·上图中黑点为音阶的主音，也就是音阶的第一音，但是一般乐器或是人的发声音域不仅仅只有七音，还包括低音（音符下方加注黑点）及高音（音符上方加注黑点），所以此一音就不只七音了。

2·当你在记忆音阶时，切记不要死背音格的位置，因为在一大调音阶中，3、4、7、i之间的距离为半音，而在吉他上每一琴格的距离即是半音，有了这个观念之后，只要在琴格上推算一下，就自然而然地把音阶记下来了。



# Guitar 7 简谱

一段旋律的产生是由音的长短与高低组合而成，在歌曲中是最能影响歌曲变化与情绪起伏的部份。记录这些音的长短与高低，在流行音乐中就用“简谱”来表示。

「简谱」，就像学校音乐课里所教的五线谱(豆芽菜)一样，里面记载了弹奏的各项资讯，也是目前在流行音乐里最通行的乐谱，您一定得学会看。以下的识谱法，笔者刻意将五线谱与简谱一起列出来，希望你不仅要会看五线谱，更要熟悉简谱。

## 一、音符

1 全音符 (○) 4 拍



2 二分音符 (◡) 2 拍

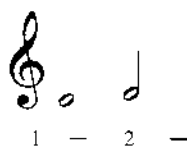

3 四分音符 (♩) 1 拍

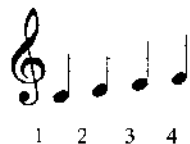

4 八分音符 (♪) 半拍



5 十六分音符 (♩♩) 1/4 拍



6 三十二分音符 (♩♩♩) 1/8 拍



## 二、附点音符

每一附点音符其拍数为前一音符之一半。

### 1 附点 4 分音符(·)



### 2 附点 8 分音符(·)



## 三、三连音

### 1 4 拍三连音



### 2 2 拍三连音



### 3 1 拍三连音



## 四、休止符

1 全休止符( — ) 4 拍

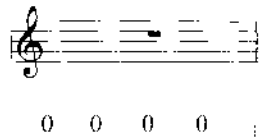

2 二分休止符( — ) 2 拍



3 四分休止符( ♩ ) 1 拍



4 八分休止符( ♪ ) 半拍



【注】



藉由脚的上下惯性摆动，是除了节拍器以外，最能够稳定拍子的一种方式，练习时千万不要忘了它的存在，尤其是在一些复拍子的弹奏上，更须要使用脚来分析拍子。

当然，最好你也能拥有一台节拍器。



以下三首练习曲，请你试着一边唱出音符一边弹出旋律。

还记得前面所提到的C大调音阶吗？笔者再把它列出来，方便你的练习！

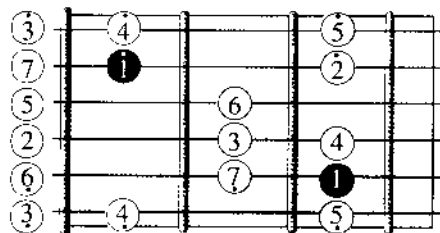

▶ 范例一 《生日快乐歌》

0 0 5 5 | 6 5 i | 7 - 5 5 | 6 5 2 | i - 5 5 |

5 3 i | 7 6 4 4 | 3 i 2 | i - - ||



## ▶ 范例二 《Love Me Tender》

C D7 G7 C

T  
A  
B

|: 5 i 7 i | 2 6 2 - | i 7 6 7 | i - - - :||

C E7 Am C7 F Fm C

T  
A  
B

| 3 3 3 3 | 3 3 3 - | 3 2 i 2 | 3 - - - |

A7 D7 G7 C

T  
A  
B

| 3 3 4 3 | 2 6 2 - | i 7 6 7 | i - - - ||





▶ 范例三 《太湖船》

C C C G

3 5 3 2 3 | 5 3 2 3 - | 3 5 3 2 1 | 2 3 5 2 3

F G C G C

1 1 6 5 6 | 1 2 3 1 - | 2 3 2 3 | 5 6 5 3 -

C G F G F G C

3 5 3 2 1 | 2 3 5 2 3 | 1 1 6 5 6 | 1 2 3 1 -

以上的练习，每行谱的最上方，笔者把它的和弦(详见第13章)列出来，您可以请你的朋友或老师帮你做伴奏，这样练习起来就好玩多了。



# 8 如何使用PICK来弹奏

## 一、Pick的种类

Pick可以分为一般Pick与拇指Pick（俗称指套）二种。一般弹奏都使用一般型的Pick居多，但在一些需要低音的乐曲中使用指套来代替拇指，会更有特色。

**Pick可依其厚薄大致分成三类：**

1. 薄的Thin (0.46 ~ 0.58 mm)
2. 中等的Medium (0.58 ~ 0.72 mm)
3. 厚的Heavy (0.72 ~ 1.2 mm)



较薄的Pick，可弹出较清脆的声音，多用于民谣吉他刷Chord时使用；较厚的Pick，弹出的音色较扎实，多用于民谣吉他或电吉他Solo时使用。



## 二、弹奏方式

一般使用Pick弹奏时，以向下弹弦的方式，音色会比较平均，但在一般具有多音的拍子上，使用单一方向的弹奏方式，速度不易增快，所以必须使用来回反覆弹奏(Alternative Picking)的方式，至于使用下压或反勾的弹奏方向，则视弹奏的习惯为主，并无一定的标准。(请参考本书第29章)

## 三、Pick的握法

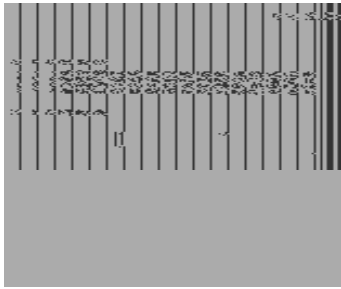

# Guitar 9 强化左右手的速度

在吉他的各种技巧中，速度算是最需要长时间不断地练习才能达成的技巧。（这里所指的「速度」，是指双手的灵活度，而非弹奏速度。）所以建议每个想弹好吉他的朋友，一定要把这种练习当作每天例行的功课，长久下来，吉他的根基必定扎实，是尔后进步的最佳利器。

接下来的四种练习方法，练习时请依次前进手指，务必将每个音都能确实弹出，切勿模拟两可，最好还能有个节拍器辅助练习。

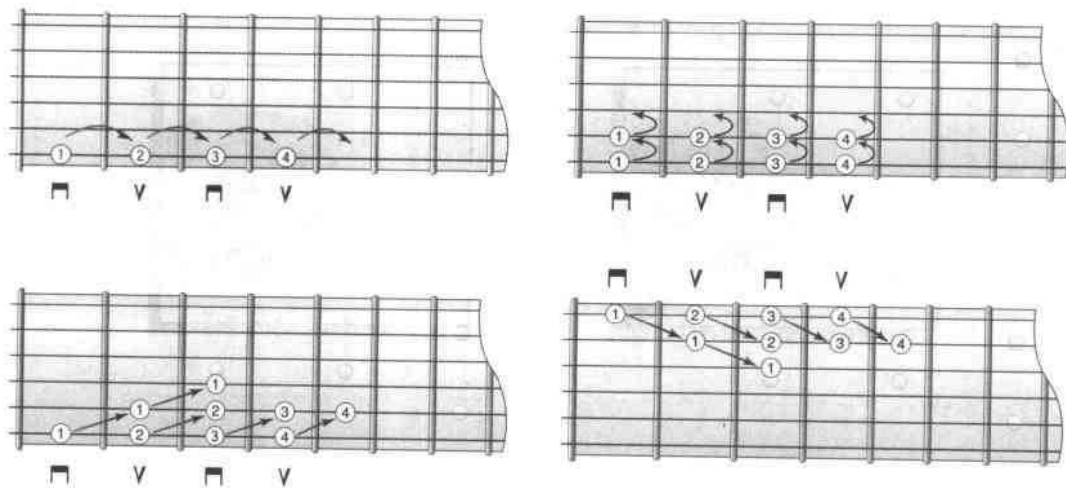

注：【一】可选择任一琴格开始练习。

【二】①②③④ 分别代表左手之食指、中指、无名指、小指。

【三】尽可能以 Pick 上下交替拨弦的方式练习。□下压、△上钩。

虽然上面的练习是依照手指1. 2. 3. 4来排列，但是你也可以改变这个顺序来练习，譬如说让手指的顺序变成像1. 3. 2. 4. 或2. 1. 3. 4. 或4. 1. 2. 3.....等等（太多变化了），每日做不一样的手指练习，可以是随性的或是任意的变化，相性很快就能适应吉他的指板了。



# Guitar 10 如何换弦

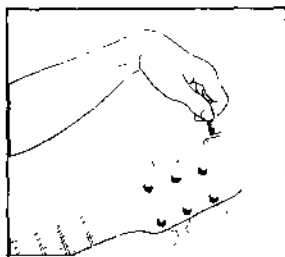

【一】使用弦卷器或以手将弦松开。

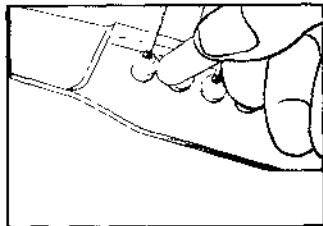

【二】使用硬质塑胶片将弦栓挖起。

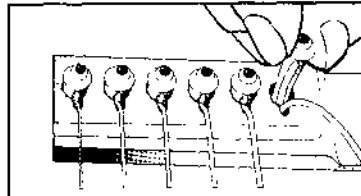

【三】将弦放入孔中后塞入弦栓，弦栓凹槽处应对准弦的方向。

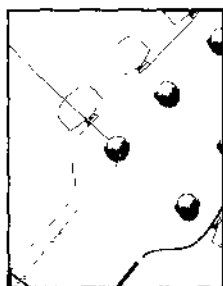

【四】将弦之另一端插入该弦之旋钮孔中。



【五】按图示方向，将弦转紧。

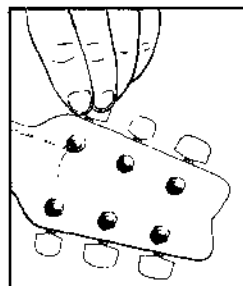

【六】再将各弦依照顺序调至其标准音高即可。

换弦时，请尽量保持一条一条换，并在换完一条弦后，即将该弦调至其标准音高，因为钢弦吉他的张力很大，为了避免琴颈所受到的张力忽然改变而造成弯曲变形，所以应尽量避免将弦全部拆下后才全部装上。

另外，如果你只断一条弦，最好买与其他弦同一厂牌同一型号之弦，不然就得换一整组新弦，因为不同厂牌弦的张力一定不同，将会破坏整体音色及平衡感。所以笔者特别建议大家要养成这种观念，这样你的吉他才能够历久弥新。



# Guitar 11 如何调音

## 一、同音乐器调音法

### 【一】使用钢琴调音：

在钢琴上依次弹出吉他之六个空弦音：

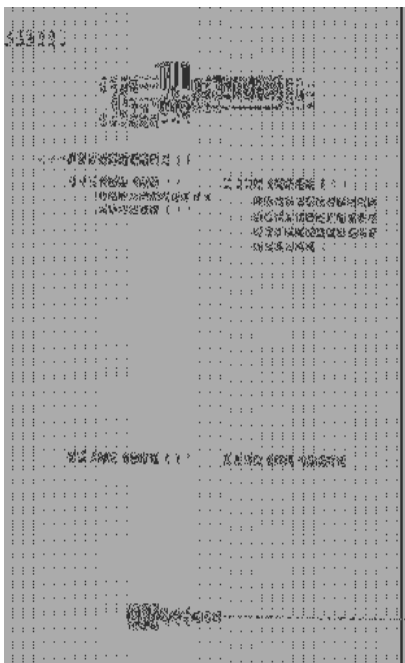

### 【二】使用电话调音：

最克难的方法，当你四周都没有调音的工具时，可以使用这种方式来调音，请调整吉他之第五弦使之与之同音。

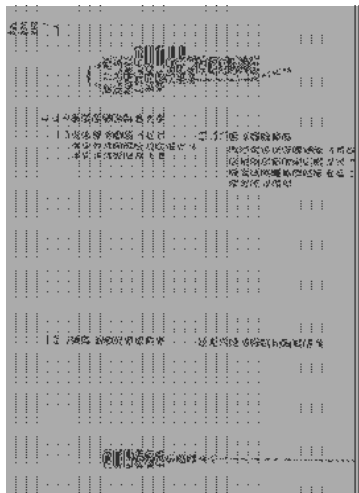

### 【三】使用调音笛调音：

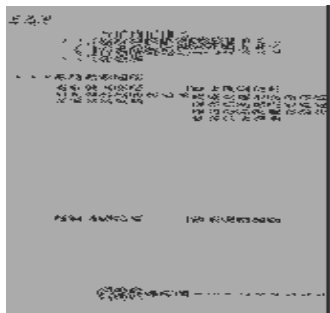

### 【四】使用电子调音器调音：

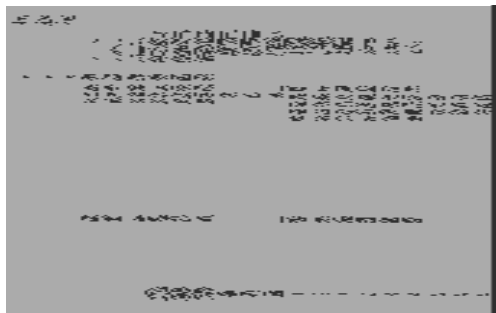

## 二、相对调音法 / Relative Tuning

### 方法（一）：标准调音法（Normal Tuning）

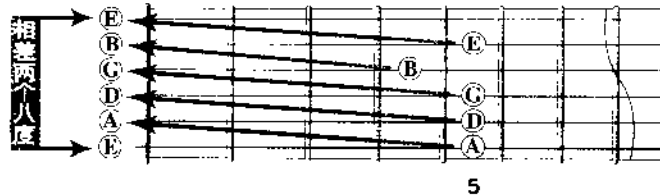

1. 首先决定第 1 空弦的基准音，如果要调整为C大调，则可比照钢琴之E音，如果调整为B调，则为钢琴之 $\flat$ E ( $\sharp$ D) 音。
2. 调整第 6 弦之空弦音，与第 1 弦相差两个八度音。
3. 按住第 6 弦第 5 琴格之A音，将第 5 弦之空弦音调整为与之同音。
4. 按住第 5 弦第 5 琴格之D音，将第 4 弦之空弦音调整为与之同音。
5. 按住第 4 弦第 5 琴格之G音，将第 3 弦之空弦音调整为与之同音。
6. 按住第 3 弦第 4 琴格之B音，将第 2 弦之空弦音调整为与之同音。

### 方法（二）：泛音调音法（Harmonics Tuning）

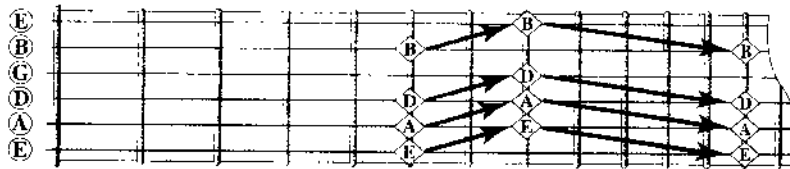

1. 首先决定第 1 空弦的基准音，如果要调整为C大调，则可比照钢琴之E音。
2. 调整第 6 弦之空弦音，与第 1 弦相差两个八度音。
3. 先弹奏第 6 弦第 5 琴格之泛音E音，再迅速弹奏第 5 弦第 7 琴格之泛音，调整为与之同音。
4. 先弹奏第 5 弦第 5 琴格之泛音A音，再迅速弹奏第 4 弦第 7 琴格之泛音，调整为与之同音。
5. 先弹奏第 4 弦第 5 琴格之泛音D音，再迅速弹奏第 3 弦第 7 琴格之泛音，调整为与之同音。
6. 弹奏第 1 弦第 7 琴格之泛音，再迅速弹奏第 2 弦之空弦音或第 2 弦第 12 琴格之泛音，调整为与之同音。



# Guitar 12 和弦

## 一、和弦

由数个（至少两个）高度不同的音，同时鸣响而产生共鸣，则称之为“和弦”或“和声”。

## 二、和弦的念法

和弦记名	和弦全名	和弦属性	组成音
C	C major	大三和弦	C E G
Cm	C minor	小三和弦	C <sup>b</sup> E G
C7	C dominant seven	属七和弦	C E G <sup>b</sup> B
Cm7	C minor seven	小七和弦	C <sup>b</sup> E G <sup>b</sup> B
Cmajor7	C major seven	大七和弦	C E G B
Cm9	C minor nine	小九和弦	C <sup>b</sup> E G B D
C9	C dominant nine	属九和弦	C E G <sup>b</sup> B D
Cadd9	C add nine	加九和弦	C E G D
C6	C six	大六和弦	C E G A
Csus4	C suspended four	挂留四和弦	C F G
C11	C dominant eleven	属十一和弦	C E G <sup>b</sup> B D F
C13	C dominant thirteen	属十三和弦	C E G <sup>b</sup> B D F A
Cm7-5(C <sup>o</sup> )	C minor seven flat five	半减和弦	C <sup>b</sup> E <sup>b</sup> G <sup>b</sup> B
Cdim7(C <sup>o</sup> )	C diminished seven	减七和弦	C <sup>b</sup> E <sup>b</sup> G A
Caug(C <sup>+</sup> )	C augmented	增三和弦	C E <sup>#</sup> G
C7+9	C seven sharp nine	属七升九和弦	C E G <sup>b</sup> B <sup>#</sup> D
C7-5	C seven flat five	属七减五和弦	C E <sup>b</sup> G <sup>b</sup> B





### 三、和弦示意图

#### (一) 和弦图表

和弦图表上

- ① 表左手食指
- ② 表左手中指
- ③ 表左手无名指
- ④ 表小指

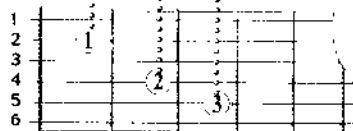
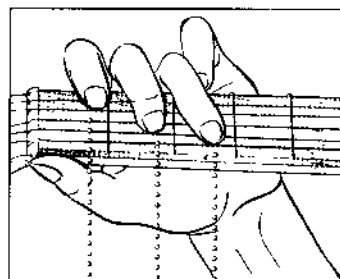

#### (二) 左手手指

压和弦时，尽量保持指尖与指板垂直，手指接触弦的位置尽量保持在靠近琴格稍下方的位置，才是能够得到最省力的方法。（如右图）

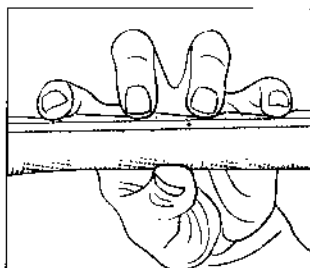

#### (三) 左手拇指姿势

左手拇指保持在琴颈中央的位置。

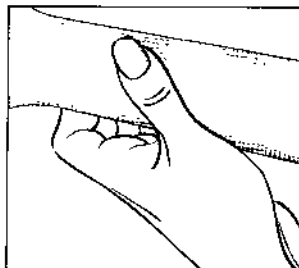

# 13 15个初学者必学和弦

C (C major)

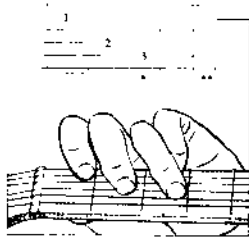

C7 (C seventh)

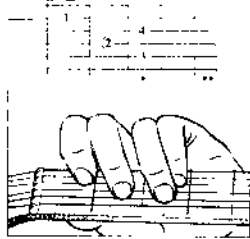

F (F major)

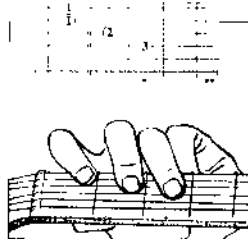

G (G major)

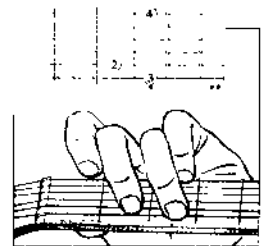

G7 (G seventh)

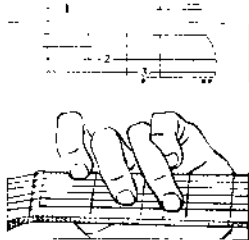

B7 (B seventh)

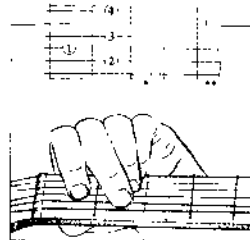

D (D major)

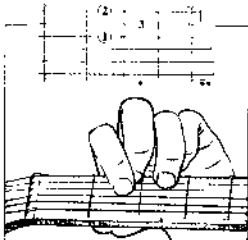

Dm (D minor)

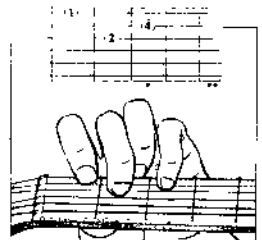

D7 (D seventh)

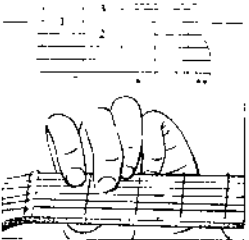

A (A major)

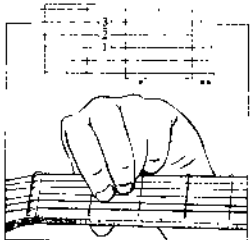

Am (A minor)

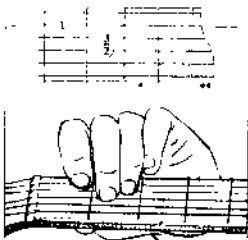

A7 (A seventh)

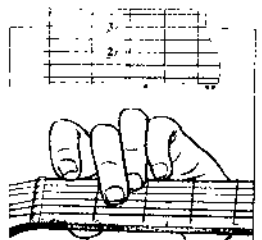

E (E major)

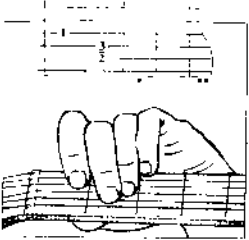

Em (E minor)

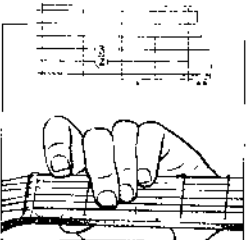

E7 (E seventh)

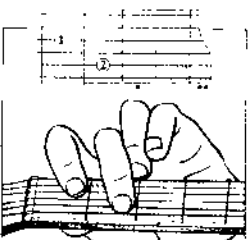

## ▶ 范例一

C      Am      Dm      G7      Cmaj7

4/4

## ▶ 范例二

C      Em      F      G      Cmaj7

4/4

## ▶ 范例三

C      G      Am      Em      F      C      Dm      G      Cmaj7

4/4

以上的练习，右手保持以一拍一下的方式来弹奏，越简单越好，眼睛请注视左手和弦的转动，一直到可以很顺利的转换和弦为止。笔者在每个范例的上方已经帮你把和弦找出来，方便你的练习，但请注意您的手指位置，尽可能得照上方手指代号的按法来练习否则日后就很难改了。



# Guitar 14 和弦转换

## 》如何加快和弦转换

嗯！在前面的练习后，相信你已经稍为可以转换一些基本的和弦了，恭喜你！但是我想你应该还会有些疑问？尤其是在一些手指需要全部移动的两个和弦上，一定伤透脑筋了。没错！的确有许多的朋友因为不能灵活的转换和弦而半途而废，所以笔者在本章中要提供几点个人转换和弦的经验，希望对你有点帮助。

### 一、先移动低音部的手指

在你移动手指时，不需急着将一个和弦一下子就按好。事实上很多和弦的转换，尤其是手指需全部移动的和弦上（例如Am换Dm、C换F），这对于刚刚接触吉他的朋友来说是很难办到的。所以笔者建议大家换和弦时，先移动低音部份的手指，因为不管在指法或是刷法的弹奏上，都是先弹根音或是低音的，所以你再转换和弦时，可以先移动低音部份的手指，这样其他手指便有充分的时间来按别的音了。如下图

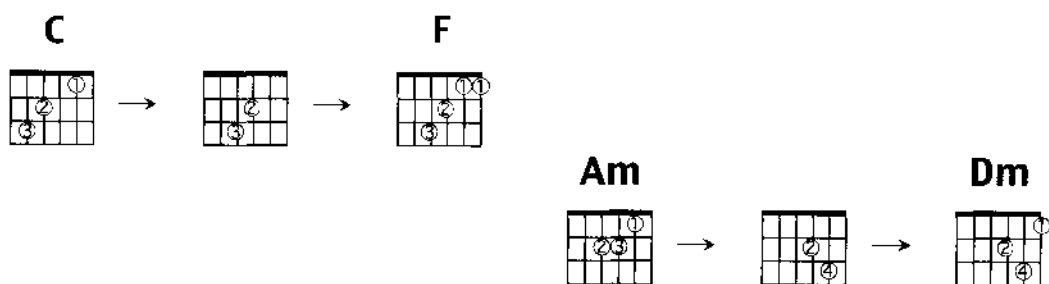

## 二、不需移动的手指，就别移动它

如果你是依照书上的压法来按和弦的，你应该可以发现，有很多和弦在转换时会有相同的音，这些相同的音你可以不须移动你的手指，只需移动不相同音的手指即可。如下图

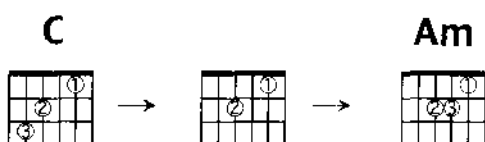

## 三、放慢速度，试着边弹边换和弦

做到以上二点后，您还得放慢速度试着边弹边换和弦，但千万不要弹完一个和弦后，让右手停下来，等下一个和弦按好后再弹，因为这样容易让你养成习惯，对于练习是没有帮助的。

好！我想和弦的转换需要练习时多多体会，掌握以上的诀窍，相信你很快就能上手了。



# 15 六线套谱上的 指法与节奏

## 》 六线套谱(TAB)上的指法与节奏

就像学古典乐看五线谱一样，吉他则是采用专属的六线谱(TAB)，不过你放心，这种谱是目前世界通行的乐谱，只不过老外习惯加上五线谱来对照。无论如何，学会弹奏六线谱(TAB)，对你来说是再重要不过了。

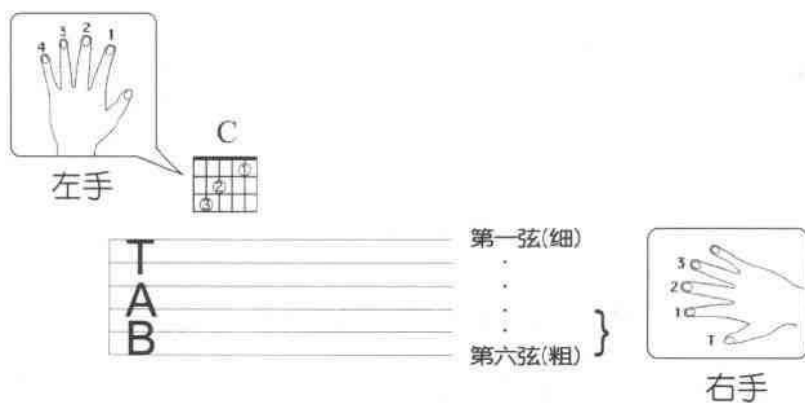

### 一、指法 / Finger Styles

- (1) “指法”又称分散和弦 (Arpeggios)，顾名思义，即是将和弦内音以分解的方式一一弹出。
- (2) 弹奏指法，笔者建议大家，不妨将右手的指甲稍微留长，这样能使弹奏的音色更加明亮。

T：姆指代号，一般弹奏和弦之根音（主音）

1：食指代号，一般弹奏第三弦

2：中指代号，一般弹奏第二弦

3：无名指代号，一般弹奏第一弦

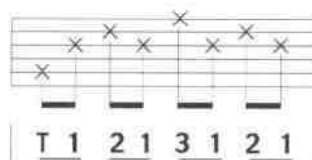
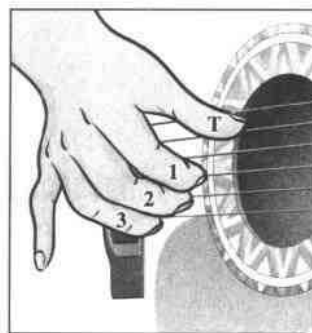

## 二、节奏/Rhythm

- (1) 节奏乃由音的长短与强弱组合而成。
- (2) 为使弹奏音色更加铿锵有力，在民谣吉他中，常使用Pick来代替手指。
- (3) 在歌曲的弹唱中，通常在歌曲的副歌或节奏强烈的乐句中，适时的加入特定节奏来演奏，以达到起承转合的目的。

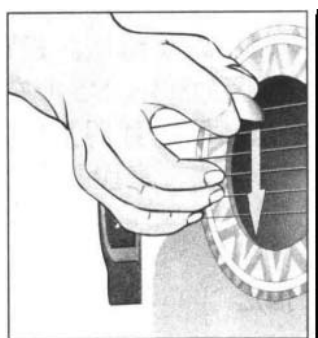

- > : 重拍记号。
- ↑ : 切音记号。
- ↑ : 闷音记号。

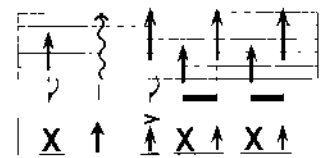

- × : 一般以弹奏三至六弦为主，右手往下击弦。
- ↑ : 一般以弹奏一至四弦为主，箭头往上，表示右手往下击弦。
- ↓ : 一般以弹奏一至四弦为主，箭头往下，表示右手往上勾弦。
- ↑ : 琶音记号。右手由上往下，以顺序的方式将每弦弹出。



# Guitar 16 音乐类型【一】 慢灵魂乐

## Slow Soul (88beat)

Slow Soul 灵魂乐，是现在流行歌曲中最常出现的节奏型态之一，你一定要会喔！就因为Slow Soul 在每小节内几乎都是以 8 分音符来弹奏，每一小节内有 8 个拍点，所以我们又称之为“8 Beat”节奏。练习时使用节拍器速度控制在  $\text{♩} = 80$  左右，最能表现此节奏的特色。以下是几种常见的弹奏方式。

指法

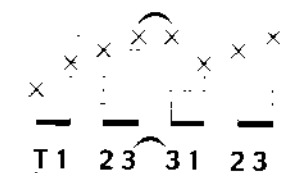
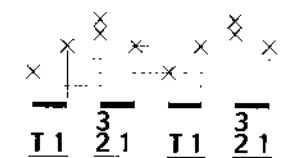
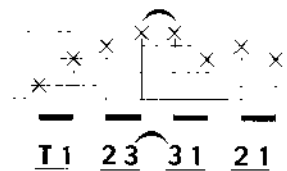
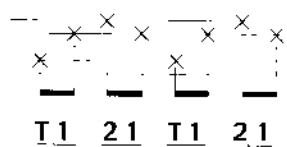
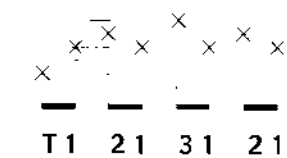

节奏

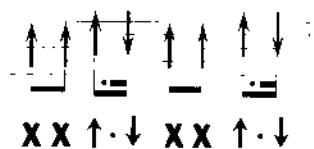
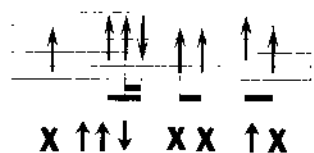
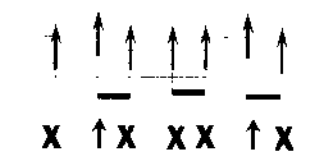
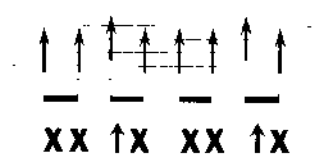

8Beat Slow Soul 不尽然都是以8分音符弹奏为主，有时可搭配16分音符或是切分音符来弹奏，但请勿搭配过多而形成另一种的节奏形态（后叙）。



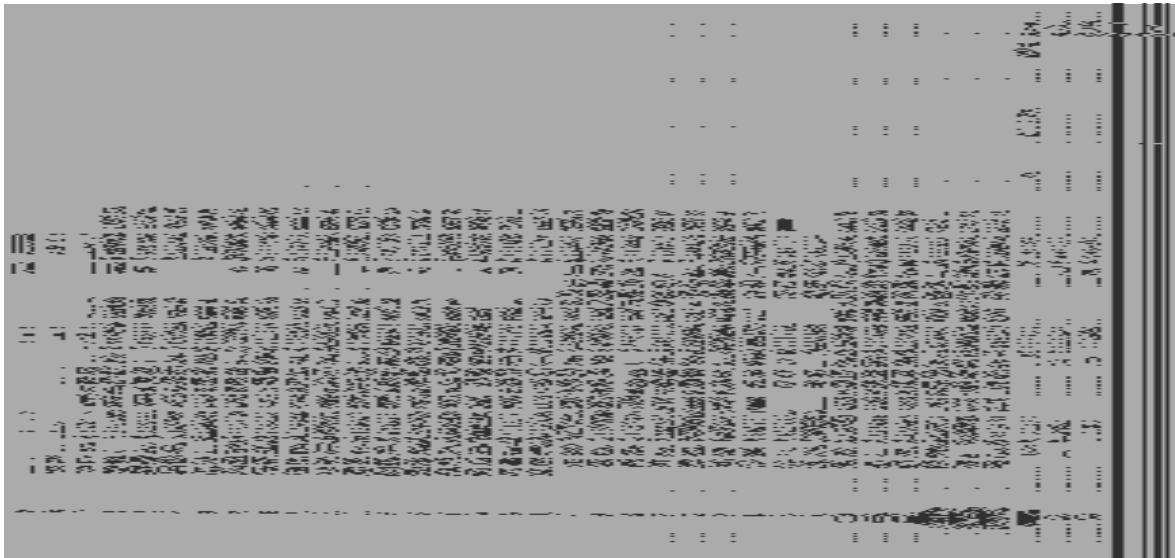

Fmaj7 Em Dm7 C Fmaj7 Em Dm7 C

0 0 0 0 | 0 0 0 0 || 3 1 6 3 2 5 2 2 | 1 1 1 1 6 . 7 7 5 5

脱下长日的假面 奔向梦幻的疆界  
隐藏自己的疲倦 表达自己的狼狈

Fmaj7 Em Dm7 C Fmaj7 Em Dm7 C

3 1 6 3 2 5 2 2 | 1 1 1 1 6 5 1 1 1 1 | 3 1 6 3 2 5 2 2 | 1 1 1 1 6 . 7 7 5 5

南瓜马车的午夜 换上童话的玻璃鞋  
放纵自己的狂野 找寻自己的明天  
让我享受这感觉 我是孤傲的蔷薇  
向你要求的誓言 就算是你的谎言

Fmaj7 Em Dm7 C Fmaj7 Em Dm7 C

3 1 6 3 2 5 2 2 | 1 1 1 1 6 5 1 1 1 1 | 0 1 6 1 1 . 0 7 5 7 7 . | 6 6 6 2 | 2 3 3 3

让我品尝这滋味 纷乱世间的 不了解  
我需要爱的慰藉 就算那爱已如潮水  
昨天太近 明天太远 默默聆听 那黑夜



Fmaj7 Em Dm7 C Fmaj7 Em Dm7 C

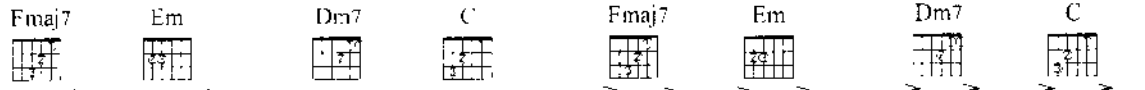

晚风吻尽 荷花叶 任我 醉倒 在池边 等你清楚看见我的美 月光 晒干眼泪

0 1 6 1 1 0 7 5 7 3 1 6 5 1 1 1 0 1 1 1 1 1 2 5 6 5 5 | 4 3 1 1 6 5 3 2 1 1 2 .

Fmaj7 Em Dm7 C Fmaj7 Em Dm7 C

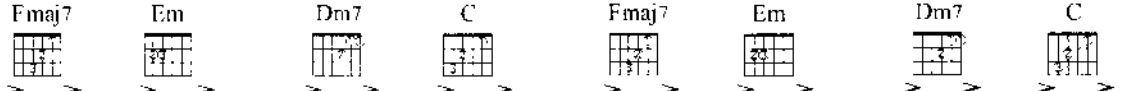

哪一个人 爱 我 将我的手 紧 握

0 6 1 6 1 1 1 0 2 . 5 | 0 5 3 2 1 6 5 5 . 6 1 | 1 0 3 . 2 1 .

Fmaj7 Em Dm7 C Fmaj7 Em Dm7 C

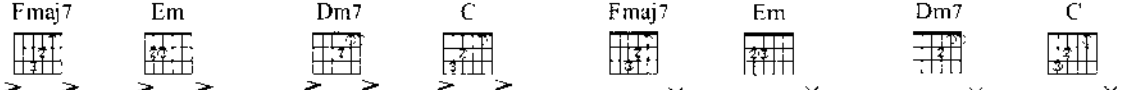

抱紧我 吻 我 喔 爱 别走

0 1 1 1 0 2 . 5 . 5 4 3 1 6 5 5 2 1 1 | 0 0 0 0 0 0 0 0

Fmaj7 Em Dm7 C Fmaj7 Em Dm7 C

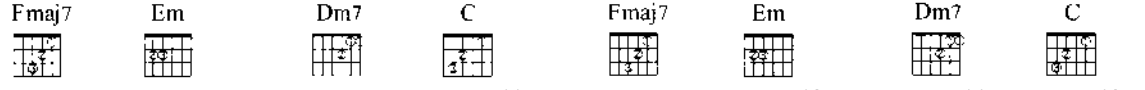

抱紧我 吻 我 喔 爱 别走

0 0 0 0 0 0 0 0 | 0 1 1 1 0 2 . 5 . 5 4 3 1 6 5 5 2 1 1 |

Fmaj7 Em Dm7 C Fmaj7 Em Dm7 C

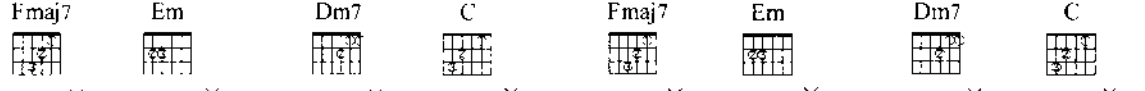

抱紧我 吻 我 喔 爱

0 1 1 1 0 2 . 5 . 5 4 3 1 6 5 5 0 0 0 0 0 0 0 0



Emaj7    Em    Dm7    C    Fmaj7    Em    Dm7    C

0 0 0 0 | 0 0 0 0 | 0 0 0 0 | 0 0 0 0

Fine



和弦主根音

C



T (根音位置)  
Do

Dm



T (根音位置)  
Re

Em



T T (根音位置)  
Mi Mi

F



T (根音位置)  
Fa

G



T (根音位置)  
Sol

Am



































T (根音位置)  
La



# 至少还有你

词/林夕 曲/Davy Char 演唱/林忆莲

Key E Play C Tempo 4/4, =63 Rhythm Slow Soul Picking | ↑ ↑ ↑ ↑ |

C 	C 	F 	F 
0 0 0 1̇ 1̇ 3 2 5 3 — — 3 2 1 6 4 4 1 2 3 4 3 2 3 2 1 5 3 — — 3 2 1 6			
F 	C 	F 	C 
4 4 1 2 3 4 3 2 0 3 3 3 5 1̇ 1̇ — 0 5 5 1 5 6 6 — 0 3 3 3 5 1̇ 1̇ 2 2 2 1 0 1 2 1			
我 怕 来 不 及 我 要 抱 着 你 直 到 感 觉 你 的 皱 纹 有 了			
Em 	F 	Fm 	C 
A7 	F 	Fm 	
3 7 7 7 6 7 7 0 5 5 6 1 1 6 2 2 1 1 5 5 3 4 4 4 3 3 3 3 6 1 1 — b6 b6 1			
岁 月 的 痕 迹 直 到 肯 定 你 是 真 的 直 到 失 去 力 气 为 了 你 我 愿			
G 	C 	F 	C 
b6 5 — — 0 3 3 3 5 1̇ 1̇ — 0 5 5 1 5 6 6 — 0 3 3 3 5 1̇ 1̇ 2 2 2 1 0 1 2 1			
意 动 也 不 能 动 也 要 看 着 你 直 到 感 觉 你 的 发 线 有 了			
Em 	F 	Fm 	C 
A7 	F 	G 	
3 7 7 7 6 7 7 0 5 5 6 1 1 6 2 2 1 1 5 5 3 3 4 4 4 3 3 3 6 1 1 0 5 5 6 1 1			
白 雪 的 痕 迹 直 到 视 线 变 得 模 糊 直 到 不 能 呼 吸 让 我 们 形 影 不 离			
C 	F 	G 	C 
G 	F 	Fm 	
1 — 1 2 3 3 3 3 2 3 3 5 5 5 5 3 2 2 2 2 1 2 2 5 5 5 5 2 1 1 1 5 5 b3 2 b3 b6 b6 1			
如 果 全 世 界 我 也 可 以 放 弃 至 少 还 有 你 值 得 我 去 珍 惜 而 你 在 这 里 就 是 生 命 的 奇 迹			



弹指之间

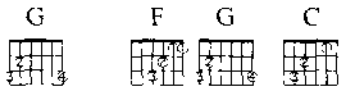

$\overset{b}{6}$  5 5 1 2 3 3 3 3 2 3 3 5 5 5 5 3 2 2 2 2 1 2 2 5 5 5 5 2 1 1 1 5 5 3 2 2 1 1

也许全世界我也可以忘记就是不愿意失去你的消息你掌心的痣我总记得在那里



1. 0 0 0 0 3 3 :|| 1 0 7 1 2 2 3 2 3 2 3 2 1 2

我怕 (E.G Solo)



0 5 6 1 5 1 2 5 2 3 2 3 2 3 2 3 2 1 1 1 5 5 1 1 5 5 1 1 5 5 5 5 7 2 6 7 0 5 5 6 1 6 1 1 5 5 3 2 2 1 3

我们好不容易我们身不由



$\overset{b}{6}$  5 5 — 0 5 5 6 1 6 1 1 5 5 3 2 2 1 1 1 2 3 3 0 0 5 5 6 1 6 1 1 5 5 3 2 2 1 3

己我怕时间太快如何将你看仔细我怕时间太慢日夜担心失去你



3 3 5 5 3 2 2 1 1 2 3 1 1 0 3 4 3 3 2 2 1 2

恨不得一夜之间白头永不分离如果%

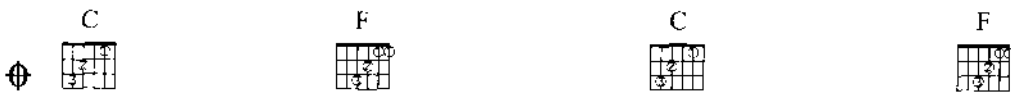

1 — — — 0 0 0 2 1 1 1 2 3 3 — — 3 — 0 0

在那里



1 — — — ||  
Fine



# 被动

词/潘丽玉 曲/吴俊霖 演唱/苏慧伦

Key F 调 Play C 谱 Capo 5 等 Tempo 4/4, =62 等 Rhythm Slow Soul 等 Picking | X ↑↑↓ X ↑↑↓ | - - -

Drum Fill

C G F C G

0 0 0 0 0 0 0 0 0 0 0 0 0 0 0 0

G

C G F C Dm7 Am

0 0 0 0 6 6 1 | 2 1 1 1 7 1 7 3 5 5 5 5 | 6 1 1 6 5 2 3 · 0 3 3 5 | 2 2 1 2 1 1 5 6 6 5 5 |

我可以 很 久 不和你联络 任日子一天天这么过 让日子 忙碌可以当作借口 逃避

F G C G F C

6 1 6 5 6 5 3 5 0 6 6 1 | 2 1 1 1 7 1 7 3 5 5 5 5 | 6 1 1 6 5 2 3 · 0 3 3 5 |

想念 你的 种种软弱 我可以 学 会 对你 很冷漠 为何 学不 会将爱 没收 面对你

Dm7 Am F G

2 2 1 2 1 1 5 6 6 5 5 6 1 6 1 6 · 6 1 6 2 2 - - 0

是对 我最 大的折磨 这些 年始终 没有 对你说

C Am Em F C

5 3 3 2 2 3 1 2 1 6 1 1 5 6 2 1 1 7 5 3 5 5 | 6 1 1 6 5 5 6 5 6 1 6 5 |

爱 你 越久我越 被动 只因 你的 爱 居无 定所是 你让 我的心 慢慢退缩退到



弹指之间

Dm7 G C Am Em  
 6 1 1 6 1 6 6 1 2 2 5 3 3 2 2 3 1 2 1 6 1 1 5 6 2 1 1 7 1 7 5 3 5 5  
 你 看 不 见 的 角 落 爱 你 越 久 我 越 被 动 只 因 我 的 爱 不 再 为 你 挥 霍 是  
 F C F Dm7 G  
 6 1 1 6 5 5 6 5 6 1 6 5 6 1 6 1 6 6 1 6 3 2 2 2 2 - - -  
 我 让 我 的 心 失 去 自 由 却 再 也 没 有 勇 气 放 纵

C G F C G F  
 6 5 1 1 6 1 2 1 5 5 3 5 2 3 2 1 1 1 1 3 5 6 5 1 1 6 1 2 1 5 5 3 5 2 1 1 1 - 0 6 6 1 :  
 我 可 以

C Am Em F C  
 5 3 3 2 2 3 1 2 1 6 1 1 5 6 2 1 1 7 5 3 5 5 6 1 1 6 5 5 6 5 6 1 6 5 :  
 爱 你 越 久 我 越 被 动 只 因 你 的 爱 居 无 定 所 是 你 让 我 的 心 慢 慢 退 缩 退 到  
 Dm7 G C Am Em  
 6 1 1 6 1 6 6 1 2 2 5 3 3 2 2 3 1 2 1 6 1 1 5 6 2 1 1 7 1 7 5 3 5 5 :  
 你 看 不 见 的 角 落 爱 你 越 久 我 越 被 动 只 因 我 的 爱 不 再 为 你 挥 霍 是  
 F C F Dm7 G  
 6 1 1 6 5 5 6 5 6 1 6 5 6 1 6 1 6 6 1 6 3 2 2 2 2 - 0 3 2 1 6 :  
 我 让 我 的 心 失 去 自 由 却 再 也 没 有 勇 气 放 纵 没 有 勇 气

C  
 6 2 1 1 1 1 - 0 0 0 0  
 放 纵

Fine



# 爱你一万年

词/杜丽 曲/大野克夫 演唱/吴俊霖

Key **Em** Play **Em** Tempo **4/4** Rhythm **Slow Soul**

Fingers | T1  $\overset{3}{2}$  T1 T1 |

Picking | X  $\uparrow\downarrow$  X  $\uparrow\downarrow$  |



0 6 1  $\underline{2\ 3}$   $\underline{2\ 1}$  6  $\underline{2\ 3}$   $\underline{3\ 3}$  3 | 0 6 1  $\underline{2\ 3}$   $\underline{2\ 1}$  6  $\underline{2\ 3}$   $\underline{\#5\ \#5}$  3 3



0 6 1  $\underline{2\ 3}$   $\underline{2\ 1}$  6  $\underline{2\ 3}$   $\underline{\#5\ \#5}$  3 3 | 3 3  $\underline{3\ 2\ 1}$   $\underline{2\ 3}$  3 | 2 2 2 2 2  $\cdot$  3  $\underline{1\ 6}$   $\underline{6\ 3\ 3}$   
寒风 吹起 细雨 迷离 风雨揭开我的记忆 我像



$\underline{5\ 5}$   $\underline{5\ 3}$   $\underline{5\ 7}$   $\underline{6\ 6}$  6 |  $\underline{2\ 2\ 1}$   $\underline{2\ 2\ 3}$   $\underline{2\ 2}$  0 3 3 | 3 3  $\underline{3\ 2\ 1}$   $\underline{2\ 3}$  3 |  
小船 寻找 港湾 不能把你忘记 爱的希望 爱的回味



$\underline{2\ 2\ 2\ 2\ 2}$   $\cdot$  3  $\underline{1\ 6}$   $\underline{6\ 3\ 3}$  |  $\underline{5\ 5}$   $\underline{5\ 3}$   $\underline{5\ 7}$   $\underline{6\ 6}$  6 |  $\underline{2\ 2}$   $\underline{2\ 1\ 2\ 3}$  2  $\underline{1\ 2}$  ||  
爱的往事难以追忆 风中 花瓣 深怕 枯萎 我要为你祝福 我爱



3  $\underline{3\ 3\ 3}$   $\underline{\#5\ \#5\ \#5}$   $\underline{\#5}$  |  $\underline{6\ 6}$   $\underline{6\ 5\ 6}$  3  $\underline{1\ 1}$  |  $\underline{2\ 2}$   $\underline{2\ 2\ 3}$   $\underline{1\ 6}$  6 |  
你 我心已属于你 今生 今世不移 在我 心中 再没有谁



$\underline{2\ 2}$   $\underline{2\ 1\ 2\ 3}$  2  $\underline{1\ 2}$  | 3  $\underline{3\ 3\ 3\ 3}$   $\underline{\#5\ \#5\ \#5}$   $\underline{\#5}$  |  $\underline{6\ 6}$   $\underline{6\ 5\ 6}$  3  $\underline{1\ 1}$   
代替 你的地位 我爱 你 对你付出真情意 不会 飘浮不定 你要







$\underline{2} \underline{2} \cdot \underline{2} \underline{2} \underline{3} \underline{1} \underline{6} \cdot \underline{6}$   
为我 再想 一想

$\underline{0} \underline{7} \underline{7} \underline{1} \underline{7} \underline{5} \underline{5} \underline{3}$   
我 决定 爱你 一万

$\parallel \underline{6} \underline{6} \underline{1} \underline{2} \underline{3} \underline{2} \underline{1} \underline{6} \underline{2} \underline{3} \underline{3} \underline{3} \parallel$   
年



$\underline{0} \underline{6} \underline{1} \underline{2} \underline{3} \underline{2} \underline{1} \underline{6} \underline{2} \underline{3} \underline{\#5} \underline{1} \underline{2}$  3  $\underline{3} \underline{3} \underline{3} \underline{\#5} \underline{\#5} \underline{\#5} \underline{\#5}$   
我爱 你 我心已 属于你

$\underline{6} \underline{6} \underline{6} \underline{5} \underline{6} \underline{3} \cdot \underline{1} \underline{1}$   
今生 今世不 移 在我



$\underline{2} \underline{2} \cdot \underline{2} \underline{2} \underline{3} \underline{1} \underline{6} \cdot \underline{6}$   
心中 再没 有谁

$\underline{2} \underline{2} \underline{2} \underline{1} \underline{2} \underline{3} \underline{2} \underline{1} \underline{2}$   
代替 你的地 位 我爱

$\underline{3} \underline{3} \underline{3} \underline{3} \underline{\#5} \underline{\#5} \underline{\#5} \underline{\#5}$   
你 对你付出真情意



$\underline{6} \underline{6} \underline{6} \underline{5} \underline{6} \underline{3} \cdot \underline{1} \underline{1}$   
不会 飘浮不 定 你要

$\underline{2} \underline{2} \cdot \underline{2} \underline{2} \underline{3} \underline{1} \underline{6} \cdot \underline{6}$   
为我 再想 一想

$\underline{0} \underline{7} \underline{7} \underline{1} \underline{7} \underline{5} \underline{5} \underline{3}$   
我 决定 爱你 一万



$\underline{6} \underline{6} \underline{1} \underline{2} \underline{3} \underline{2} \underline{1} \underline{6} \underline{2} \underline{3} \underline{3} \underline{3}$   
年

$\underline{0} \underline{6} \underline{1} \underline{2} \underline{3} \underline{2} \underline{1} \underline{6} \underline{2} \underline{3} \underline{\#5} \underline{\#5}$

$\underline{0} \underline{6} \underline{1} \underline{2} \underline{3} \underline{2} \underline{1} \underline{6} \underline{2} \underline{3} \underline{3} \underline{3}$



$\underline{0} \underline{6} \underline{1} \underline{2} \underline{3} \underline{2} \underline{1} \underline{6} \underline{2} \underline{3} \underline{\#5} \underline{\#5}$

6 - - -

Fine



# 17 音乐类型【二】 民谣摇滚 Folk Rock

Folk Rock节奏是最能表现吉他特色的一种节奏，节奏以8Beat型态为主，轻快活泼，吉他入门者一定要学会。

如果再配上几个基础和弦，相信很快就能运用到吉他的世界。练习时使用节拍器速度控制在♩=120以上，最能表现此节奏的特色。

## 指法

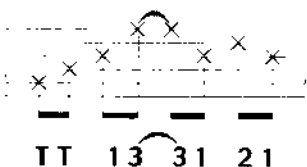
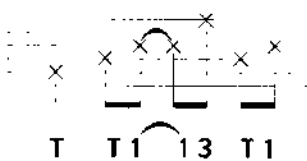
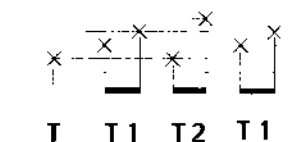

## 节奏

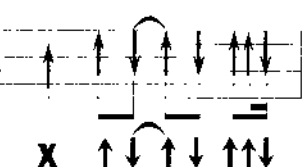
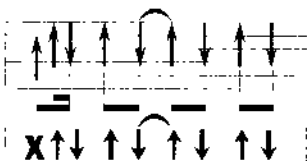
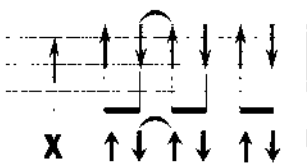

## 加入附点切分音符而形成Swing节奏

Swing节奏是「爵士乐」的重要元素之一，请你务必体会出这种“摇摆”的感觉。

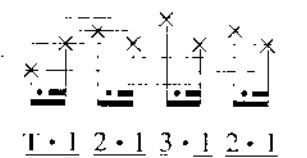

# 静 止

词 / 大张伟 曲 / 大张伟 演唱 / 杨乃文

Key D Play C Capo 2 Tempo 4/4 Rhythm Soul Picking | x ↑ ↓ ↑ ↓ ↑ ↓ |



2 3

3 2

3

3 2

|

2 3

3 2

3

3 2

2 3

3 2

3

3 4

4 4

4 3

4 3

4 5



2 3

3 2

3

3 2

2 2

2 2

2 4

4 4

2 3

3 2

3

3 2

2 3

3 2

3

3 2



2 3

3 2

3

3 4

4 4

4 3

4 3

4 5

2 3

3 2

3

3 2

2 2

2 2

0 5

5 5

寂寞围



3

2 3

3 3

3

3

3

2 3

3 3

3 1

|

3 1

1 2

2 3

3 3

|

3

—

0 3

4 3

绕 着 电 视  
瞬 间 消 失

垂 死 坚 持 在  
被 稀 释 不

两 点 半 消 失  
停 转 动 着 手 指

多 希 望  
我 幻 想



1 1

1 1

1 6

6

0

2 1

3

2

5 5

5 4

4 3

3 2

2

3 3

3 1

2 1

有 人 来 陪 我  
美 丽 的 生 活

度 过 未 日  
何 时 开 始

空 虚 敲 打 着  
时 光 不 经 意

意 志 仿 佛 这  
流 逝 像 颗 在



4 3

3 1

1 2

3 3

3

—

0 3

4 3

|

1 1

1 1

1 6

6

0

2 1

3

2 1

时 间 已 静 止  
耗 费 的 电 池

我 怀 疑  
我 感 到

人 们 的 生 活  
有 点 失 落

有 所 掩 饰  
无 法 抑 制







5 4 4 3 3 2 2 5 5    5 4 4 3 3 2 2 5 5    5 4 4 3 3 2 2 1    2 3 2 1 2 1 1 |



|: 1 — 0 4 3 4 1 — 0 4 3 4 3 — — — 2 1 3 3 2 2 1 |  
 啊 啊 啊 啊 啊 啊 垂 死 坚 持



1 — 0 4 3 4 | 1 — 0 4 3 4 3 — — — | 2 1 3 3 2 2 1 :|  
 啊 啊 啊 啊 啊 啊 全 部 消 失



3 — 3 — — — 3 — — — 3 — — — 1 2 2 2 2 — 0 5 5 5  
 已 静 止 寂 寞 围 绕



1 1 1 1 2 1 1    0 2 1 3 2 1 1 — — — 1 — — — |  
 人 们 的 生 活    有 所 掩 饰

Fine



## 花心

词/厉曼婷 曲/齐纳 演唱/周华健

● Key G ● Play G ● Tempo 4/4 ● Rhythm Folk Rock ● Picking | X ↑ ↓ ↑ ↓ ↑ ↓ |



5 - -



6 5 | 2 · 1 1 - |



3 2 2 - 6 |



i - - 3 5 |



5 · 5 5 · 3



6 5 3 -



2 3 |



2 · 2 2 6 |



i - - - ||



0 0 5 5



6 6

1 2 3 1 |



2 3 2 1 7 7 1 |



1 - - -



1 - - -



0 0 5 5



6 6

1 1 1 5 |



6 1 6 5 3 3 5 |



5 - - -



5 - - -



0 0 5 5



6 6

1 2 3 1 |



2 2 2 3 1 6 5 |



5 - 3 5



5 - 3 5



0 3 3 3 3



2 1 0 2 2 3 2 1 7 |



7 7 7 7 7 1 2 1 |



1 - - -



1 - - - ||

黑夜又白潮  
起又潮

昼落































黑夜又白潮  
起又潮

昼落

人生为欢有  
送走人间许

几多  
何愁



C 	Am 	F 	Fm 
: 0 5 5 5 6 1   1 - - 0 1 2 1 6 5   5 6 5 3 5			
春去春会来 - - 花谢花会再开			
Am 	Dm7 	G7 	C 
0 3 3 3 2 1   0 2 2 3 2 1 7   7 7 7 7 7 1 2 1   1 - - - :			
只要你愿意 只要你愿意 让梦滑向你心海			
C 	Am 	Dm7 	C 
5 - - 6 1 - - 0 6 3 2 2 - 6   1 - - 3 5			
C 	Am 	Dm7 	G7 
5 5 5 3 6 5 3 - 2 3 2 2 2 2 6   1 - - -			
C 	Am 	Dm7 	C 
0 0 0 0 0 0 0 0 0 0 0 0 0 0 0 0			
C 	Am 	Dm7 	G7 
0 0 0 0   0 0 0 0 0 0 0 0 0 0 0 0			
Am 	Dm7 	G7 	C 
0 3 3 3 2 1   0 2 2 3 2 1 7   7 7 7 7 7 1 2 1   1 - - -			
只要你愿意 只要你愿意 让梦滑向你心海			
Am 	Dm7 	C 	
1 2 6 - 5 6 5 - 0 3 2 1 - - -			

Fine



# 分享

词/姚谦 曲/伍思凯 演唱/伍思凯



F



C



5



4/4



Folk Rock



Picking



| X ↑ ↓ ↑ ↓ ↓ ↓ |



0 0 0 0 1 2 | 3 5 1 2 5 2 5 7 2 5 | 1 3 6 1 2 1 3 6 5 | 0 6 4 1 4 3 1 5 3



2 - 1 7 | 1 - - - | 1 - 0 0 3 4 | 5 5 6 6 3 5 5 . 5 1 2 2 |  
时间 已做了 选择 什么人叫



2 3 2 1 | 0 7 1 1 7 5 | 6 - 0 5 1 1 3 4 | 3 3 2 2 1 5 5 0 3 4 | 5 5 6 6 3 5 5 . 5 1 2 2 |  
做朋友 偶而 碰头 心情 却能 一点 就通 因为 我们曾 有过 理想类似



2 3 2 1 | 0 7 1 1 7 5 6 | 6 - 0 5 1 1 3 4 | 3 3 2 2 1 3 3 2 . 2 | 0 7 7 7 1 5 6 6 5 5 4 5 |  
的生活 太多 感受 绝非 三言 两语 能形 容 可能 有时 我们 顾 虑太



5 3 . 3 - 0 | 0 7 7 7 1 5 6 6 5 5 4 4 | 4 5 3 3 - 0 3 3 | 3 2 2 2 2 - 0 2 3 |  
多 太多 决定 需要我 们去 选择 担心 会 犯错 难免



弹指之间



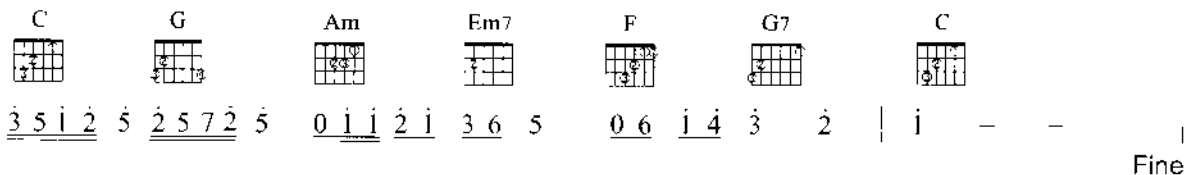
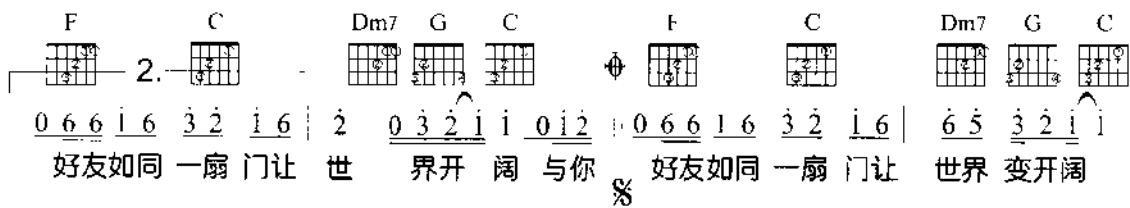
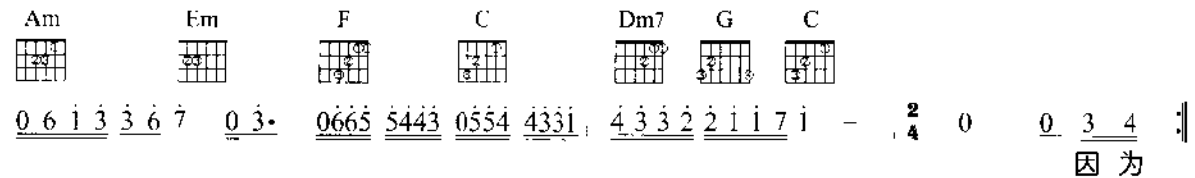
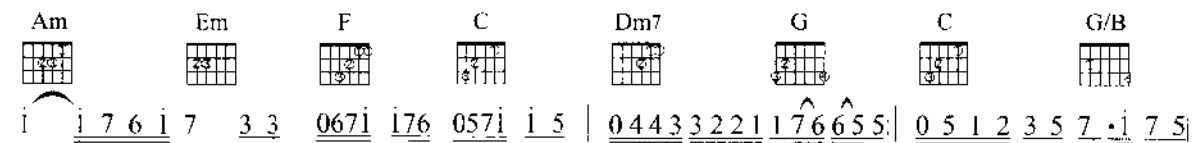
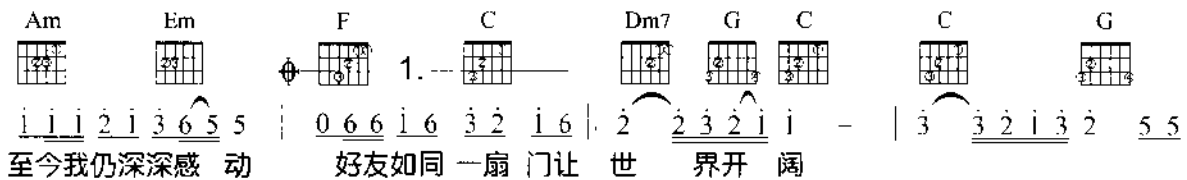
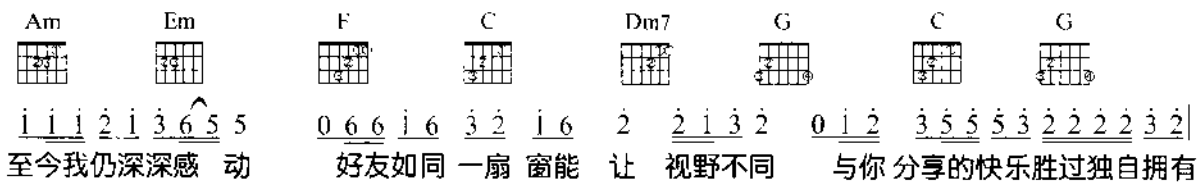
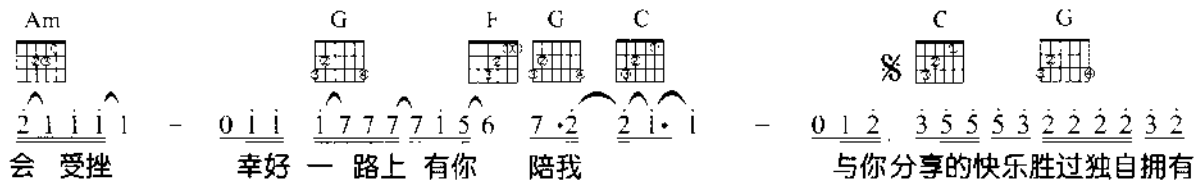

# Guitar 18 音乐类型【三】 华尔兹 Waltz

Waltz (华尔兹) 多半为3/4拍型式出现于歌曲中, 但有时也加入切分音而成为“Swing Waltz”。

指法

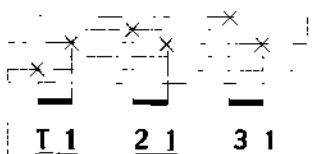
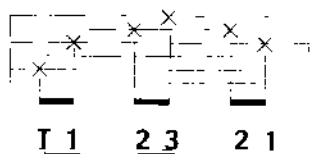

节奏

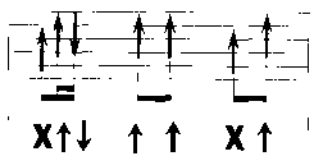
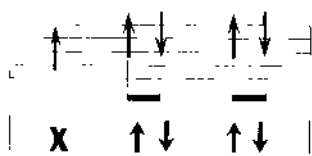

加入切分音之后的Swing Waltz

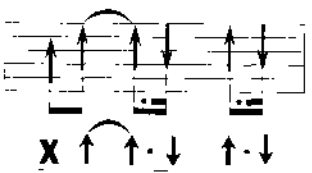
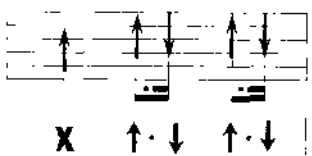
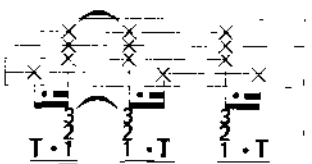
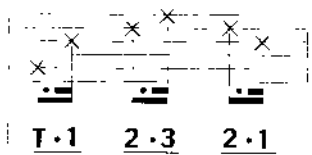

# 棋子

词/潘丽玉 曲/杨明煌 演唱/王菲

● Key Am ● Play Am ● Tempo 3/4 ● Rhythm Swing Waltz ● Picking | T-1 2-1 3-1 |



3̣ 1̣ 6̣ 3̣ 1̣ 6̣ 3̣ 7̣ 5̣ 3̣ 7̣ 5̣ | 1̣ 6̣ 4̣ 1̣ 6̣ 4̣ 7̣ 5̣ 2̣ 3̣ 5̣ 7̣ 3̣ 1̣ 6̣ 3̣ 1̣ 6̣ 3̣ 7̣ 5̣ 3̣ 7̣ 5̣



$\frac{2}{4}$  1̣ 6̣ 4̣ 1̣ 6̣ 4̣  $\frac{4}{4}$  7̣ - - 1̣ . 2̣ 3̣ 2̣ 1̣ 7̣ 1̣ 7̣



6̣ 7̣ 1̣ | 7̣ - 1̣ . 2̣ 3̣ 2̣ 1̣ 7̣ 1̣ 7̣ | 5̣ - - - 1̣ . 2̣ |



3̣ . 2̣ 3̣ 2̣ . 1̣ 2̣ 1̣ 7̣ 1̣ 7̣ 6̣ | 7̣ - 5̣ 6̣ - - 5̣ - -



6̣ - - - 0 0 . 3̣ | 6̣ 6̣ 7̣ 1̣ 1̣ 1̣ 2̣ 1̣ 1̣ . 7̣ 6̣ - 0 . 3̣  
想 走 出 你 控 制 的 领 域 却  
逃 离 你 你 布 下 的 陷 阱 却



6̣ 6̣ 7̣ | 1̣ 1̣ 1̣ 2̣ - 2̣ . 1̣ | 3̣ - 0 . 6̣ | 6̣ - 5̣ 6̣ 5̣ 5̣ . 2̣  
走 进 你 安 排 的 战 局 境 我 没 有 坚 强 的  
陷 入 了 另 一 个 困 境 我 没 有 决 定 的 输



Em7 Am7 F Em7 Am

2 1 1.7 6 - 0.3 6 6 7 1 7 - 6 5 | 6 - - | - 0 0.3 |

防 赢 的 勇 气 也 没 有 后 路 脱 可 以 退 想

Am F G Em Em7

6 - - - 0 0.1 | 6 - 5 6 - 5 3 - - | - 0 0.6 |

运 我 像 是 一 颗 棋 进

F G Em Em7 F G

6 - 5 6 5 0.2 3 - - - 0 0.1 6 6 6 | 6 5 - |

退 任 由 你 决 定 我 不 是 你 眼 中

Em7 Am7 F Em Am

2 1 1.7 6 - 0.3 6 - 7 1 7 - 6 5 | 6 - - | - 0 0.6 |

惟 一 将 领 却 是 不 起 眼 的 小 兵 我

F G Em Em7 F G

6 - 5 6 5 2 | 3 - - - 0 0.6 | 6 - 5 | 6 5 2 |

像 是 一 颗 棋 子 来 去 全 不 由 自

Em Em7 F G Em7 Am7

3 - - - 0 0.6 | 6 - 6 6 5 0.2 | 2 1 7 | 6 - 0.3 |

己 举 手 无 回 你 从 不 曾 犹 豫 我

F Em Am Am7 Em7/G



6 - 7 1 7 - 6 5 | 6 - - - 0 0 | 3 6 1 3 3 5 7 3 |

却 受 控 在 你 手 里



Fmaj7 Em7 Am Em7/G Fmaj7 Em7

3 6 1 3 2 0.5 7 2 3 1 6 3 1 6 | 3 7 5 3 7 5 | 1 6 3 6 3 1 2 - 6 7 1 2 3 4 |







5 - - 1 7 6 3 6 7 i - 6 7 i 2 3 4 | 5 - - i 7 6











3 6 7 i - 6 7 i 2 3 4 5 - - 6 i 2 3 - 0 6 7 i 2 3 2 i 7 6 # 5 3 0 · 3 |





6 - - - 0 0 · 1 6 6 | 6 5 0 · 2 3 - - - 0 0 |

里 我 像 是 一 颗 棋 子 **想 D.S.**





6 6 6 6 5 0 · 2 3 - - - 0 0 · 1 6 - 6 6 5 0 · 2 |

来 去 全 不 由 自 己 举 手 无 回 你 从





2 1 7 6 - 0 · 3 6 - 7 1 7 - 6 5 6 - - - 0 0 · 3 |

不 曾 犹 豫 我 却 受 控 在 你 手 里 我





6 - 7 1 7 - 6 5 6 - - 0 0 · 3 6 - 7 1 7 - - |

却 受 控 在 你 手 里 我 却 受 控 在

6 - 5 || 6 6 i 3 3 5 7 3 | 3 6 i 3 | 2 0 5 7 2 |

你 手 里

3 i 6 3 i 6 | 3 7 5 3 7 5 | i 6 3 6 3 1 | 2 - 5 6 - - | - 0 0 |

**Fine**



# Guitar 19 复合和弦

## Polychord

### 》 复合和弦/Polychords

当和弦之根音不是落在其主音上，而是落在其它的音上，我们就通称这类的和弦叫「复合和弦」。

复合和弦有两种，一种是根音落在和弦内音上，我们叫它「转位和弦」(Inversion Chord)。另一种是根音落在和弦的外音上，我们叫它「分割和弦」(Slash Chord)。

#### 转位和弦/Inversion

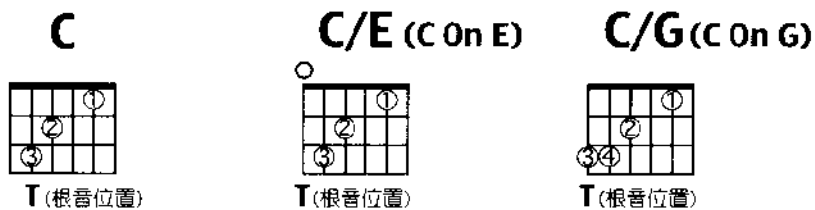

#### 分割和弦/Slash

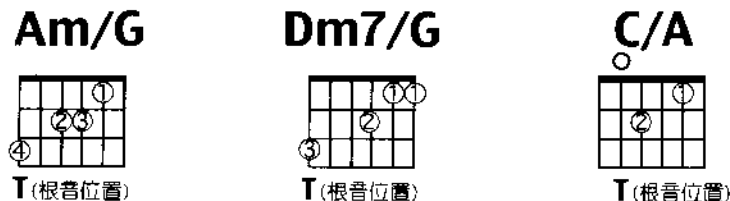

▶ 范例一

C G/B Am Am7/G F C/E Dm7 G7 C

▶ 范例二

G D#F Em Em/D C G/B Am7 D G

▶ 范例三

D D#C Bm Bm/A

G D#F Em7 A D

▶ 范例四

E B#D #Cm #Cm7/B









A E#G #Fm7 B E











## 朋友

词/刘思谔 曲/刘志宏 演唱/周华健







● Key C ● Play C ● Tempo 4/4 ♩ = 70 ● Rhythm Slow Soul ● Picking | X ↑↑↓ X ↑↑↓ |

 C     G/B     Am     Em     F     Em     Dm7     G  
 0 2 3 2 — | 0 1 3 5 — | 0 2 3 1 6 3 | 2 — — —









啊...

 C     G/B     Am     Em     F     Em     Dm7     G  
 1 2 3 2 3 5 6 5 3 3 2 3 | 1 2 3 6 2 3 | 2 6 1 1 —







啊...

 C     Am     Em     Am     Dm7     F  
 1 — 0 2 3 | 1 2 3 1 2 3 | 5 5 6 1 6 1 | 2 2 1 6 6 1









这些 年 一个 人 风也 走 雨也 过 有过 泪 有过 错 还记

 Dm7     G     C     Am     Em     Am     Dm7     F  
 2 3 2 1 2 3 2 | 1 2 3 1 2 3 | 5 5 6 1 6 1 | 2 2 1 6 5 6







得坚 持什么 真爱 过 才会 懂 会寂 寞 会回 首 终有 梦 终有 你 在心

 C     C     G/B     Am     Am7/G     F     Em  
 1 1 1 — 3 5 | 5 5 5 6 5 6 7 | 1 6 6 5 3 3 2 | 1 1 6 5 3 2

中 朋友 一生 一起 走 那些 日子 不再 有 一句 话 一辈子 一生

 Dm7     G     C     G/B     Am     Am7/G     F     Em  
 1 1 6 2 2 3 5 | 5 5 5 6 5 6 7 | 1 6 6 5 3 3 2 | 1 1 6 5 3 2

情 一杯 酒 朋友 不曾 孤单 过 一生 朋友 你会 懂 还有 伤 还有 痛 还要

 Dm7     G     C    1. (转 A key )  A     E     F#m 2fr.  
 1 6 6 1 1 1 1 2 1 | 0 4 3 — 2 3 | 1 — — —

走 还有 我 嘿 呀



A F #Fm 2fr G A

3 - - 2 3 | 1 - - - 2 - 2 2 3 - - - |

嘿 - - - 呀 嘿 - - - 呀

G C (转 C key )

2 - 2 2 | 3 - - - - 2 3 :| 2/4 0 3 5 |

嘿 - - - 呀 这些 朋友

C G/B Am Am7.G F Em Dm7 G

5 5 5 6 5 6 7 | 1 6 6 5 3 3 2 | 1 1 6 5 3 2 | 1 1 6 2 2 3 5 |

一生一起走那些日子不再有一句话一辈子一生情一杯酒朋友

C G/B Am Am7.G F Em Dm7 G

5 5 5 6 5 6 7 | 1 6 6 5 3 3 2 | 1 1 6 5 3 2 | 1 6 6 1 1 1 1 |

不曾孤单过一生朋友你会懂还有伤还有痛还要走还有我

#G 4fr. (转 #C key )

0 0 0 3 5 |

朋友 %

#C #G/C #Am 4fr. Fm #C 4fr. Cm 3fr. bBm7 #D7 4fr.

:| 0 5 3 2 . 2 3 | 2 - - - 0 6 5 1 . 2 3 | 2 - - - :|

嘿 呀 嘿 嘿 嘿 呀 嘿 嘿 嘿

Fade out



# 身边

词/于光中、李宗盛 曲/品冠 演唱/无印良品



4/4 = 98



Soul

C/G    Dm7/G    Gsus4    G    Cmaj7    Bb/G

5 5 1 5    5 6 1 4    5 4 7 2    5 5 7 2    7 1 7 1    7 5 5    5 7 2 4 4 -

Cmaj7    G9sus4    C    G/B    Am7    Am7/G

7 1 7 1 7 1 1    5 - 0 0    5 4 4 3 4 3 2 1    3 4 5 1 1 3 3

坐在你的身边是种满足的体验

F    C/E    Dm7    C    G/B    Am7    Am7/G

6 5 5 4 5 1 1 6    6 5 5 4 5 -    5 4 4 3 4 3 2 1    3 4 5 1 1 3 3

看你看的画面过你过的时间    天也晴了花也开了    微风也沉醉



F C/E Dm7 Dm7 G C Gsus4

6 5 5 4 5 1 1 3 3 4 3 4 5 7 2 2 1 1 - - 0 0 1 2 3 4

虽然你不说话却也早已万语千言分分秒秒

C G/B Am7 Am7 G F G Cadd9

5 5 4 3 2 3 3 2 1 1 2 1 1 6 6 6 6 5 5 5 5 - 5 6 5

显得清澈又珍贵只有你才能给我这种感觉不管心

F C Dm7 G

1 5 6 1 1 5 6 5 1 5 5 3 3 1 2 3 4 4 4 3 2 5 5 5 5 - 5 6 1 5

多疲倦梦想还有多远有你陪伴一切都无所谓我要陪你

Cadd9 G/B Am7 Am7/G

2 1 2 1 2 3 3 2 2 1 2 1 2 5 5 5 1 7 6 6 6 7 7 6 5 - 5 4 4 3

擦拭每个昨天相片日记书签有暖意慢慢浮现我要用默

F Em Dm7 Dm7/G

4 3 1 1 1 7 7 1 7 1 7 5 5 5 4 4 3 4 3 1 3 3 3 2 5 6 1 5

默的体贴让你睁开双眼看见昨夜梦想都实现我也愿意



Cadd9 G/B Am7 Am7/G

2 1 2 1 2 3 3 1 2 1 2 5 5 5 1 7 6 6 6 7 7 6 5 - 5 4 4 3

帮你 打扫 房间 把 身体 好好 锻炼 好 让你 觉得 安 全 让你 记得

F Em Dm7 Dm7/G 1.

4 3 1 1 1 7 7 1 7 1 7 5 5 5 4 4 3 4 5 5 0 0 5 6 5 1

我的 优点 无 论 任何 时间 对我 非常 想念 非常 想念

C G/B Am7 Am7/G C G/B Am7 Am7/G

1 1 2 2 1 2 3 4 3 1 1 - 1 1 2 2 1 2 3 4 3 1 1 -

Dm7/G Dm7/G 2. F#sus2 D# F# G#

1 1 1 - - 0 0 5 6 5 1 2 1 - - - 0 0 5 6 1 5

非常想念 (转C Key) 我要 陪你

#Cadd9 #G/C #Am #Am/#G

2 1 2 1 2 3 3 2 2 1 2 1 2 5 5 5 1 7 6 6 6 7 7 6 5 - 5 4 4 3

擦拭 每个 昨天 相 片 日记 书签 有 暖意 慢慢 浮 现 我要 用默





# 约定

词/姚若龙 曲/姚若龙、陈小霞 演唱/周慧



E

Key



C

Play



4

Capo



4/4, = 80

Tempo



Slow Soul

Rhythm

Fmaj7 Em Am Em  
 3 — — 3 6 7 5 5 5 · 1 7 1 — 1 · 1 1 2 7 1 7 5 5 —

F Em Dm7 G  
 3 2 3 1 1 1 1 2 4 0 3 3 3 3 0 1 0 1 2 1 3 5 5 3 3 X X X 2 X X 1 3 1  
 4 3 4 1 1 · 1 7 5 5 2 2 · 2 3 4 3 1 6 1 · 6 6 5 2 — — 2 1 2 1

G C Fm7/B Am  
 7 — — 0.5 1 2 3 2 1 3 2 · 5 5 · 3 6 7 1 7 6 1  
 远 处的 钟 声 回 荡 在 雨 里 我 们 在 屋 檐 底 下



弹指之间

Em F Em Am F Dm7

7 · 3 5 — 6 5 5 4 5 i 4 3 2 · 1 i · 2 3 4 3 2 j i 6 |

牵 手 听 幻 想 教 堂 里 头 那 场 婚 礼 是 为 祝 福 我 俩 而 举

G C Em7/B Am

2 — — 0 5 | 1 2 3 2 i 3 2 · 7 5 · 3 6 7 i 7 6 i

行 一 路 从 泥 泞 走 到 了 美 景 习 惯 在 彼 此 眼 中

Em F Em Am F Dm7

7 · 3 5 — 6 5 5 4 5 i · 2 · 3 i 6 7 i 6 i · 6 6 5

找 勇 气 累 到 无 力 总 会 想 吻 你 才 能 忘 了 情 路 艰

Gsus4 G C Em7/B Am

5 5 5 — — 5 — — 2 i 5 · 3 3 3 2 i 7 i 7 6 · 3 3 6 6 i 2 i

辛 你 我 约 定 难 过 的 往 事 不 许 提 也 答 应

F Dm7 G Em Am Em Am

6 4 4 3 4 6 7 i | 2 — — 0 3 4 5 5 5 6 i — 0 5 7 2 i · 2 3

永 远 都 不 让 对 方 担 心 要 做 快 乐 的 自 己 照 顾 自 己 就 算



F Dm7 Gsus4 G C Em7/B Am

6 1 4 3 4 4 5 | 3 2 2 — 1 2 1 | 5 . 3 3 3 2 1 7 1 7 | 6 . 3 3 6 6 1 2 1

某 天 一 个 人 孤 寂 你 我 约 定 一 争 吵 很 快 要 喊 停 也 说 好

F Dm7 G Em Am Em Am

6 4 4 3 4 6 7 1 | 2 — 0 3 4 | 5 5 5 6 1 — | 0 5 7 2 1 . 2 3

没 有 秘 密 彼 此 很 透 明 我 会 好 好 的 爱 你 傻 傻 爱 你 不 去

F G C Am Em7/B F

3 6 4 3 1 2 | 3 4 3 4 2 2 2 . 6 7 | 1 7 1 7 6 5 5 . 6 7 | 1 1 1 5 5 5 4 4 3 2 1

计 较 公 平 不 公 平

Em F6 F/A Dm7 G

2 3 5 5 2 3 2 1 — | 0 5 4 3 . 1 1 6 7 | 1 — 1 2 3 4 | 2 — — 0 5 :





F G C Em Am Em Am



3 6 4 3 1 2 | 1 — — 0 3 4 | 5 5 5 6 1 — | 0 5 7 2 1 . 2 3

计 较 公 平 不 公 平 我 会 好 好 的 爱 你 傻 傻 爱 你 不 去





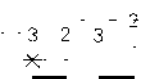

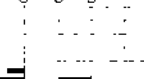
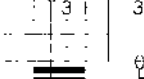





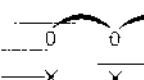

3 6 4 3 1 2 | 1 — 1 1 1 6 | 5 3 3 3 3 1 3 1 | 3 3 3 3 2 4 2 |

计 较 公 平 不 公 平

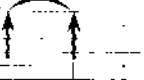
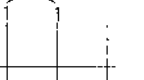
5 — — 0 1 4 5 | 6 — — — | 5 — 5 6 4 4 | 3 — — — |



3 — — — |

Fine



# 20 音乐类型【四】 慢摇滚 Slow Rock

Slow Rock 又称“慢摇滚”节奏，因其在每一拍上均有三个拍点，所以有时可称之为“三连音”的伴奏方式。如果我们将三连音中间的拍点去掉，那就变成了“Shuffle”节奏了。练习时使用节拍器速度控制在  $\text{♩} = 100$  左右，最能表现此节奏的特色。

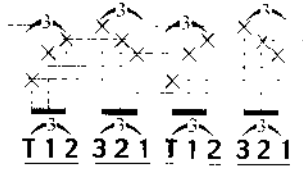
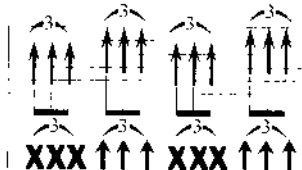
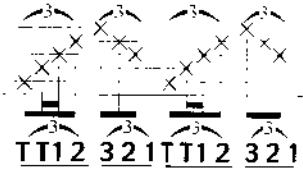
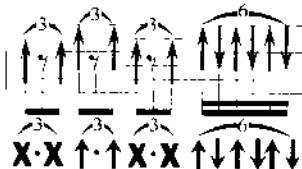
指法	 <p>T 1 2 3 2 1 T 1 2 3 2 1</p>	节奏	 <p>XXX ↑↑↑ XXX ↑↑↑</p>
	 <p>T 1 2 3 2 1 T 1 2 3 2 1</p>		 <p>X·X ↑·↑ X·X ↑·↑</p>

## 加入切分音之后的“Shuffle”节奏

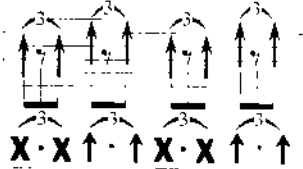
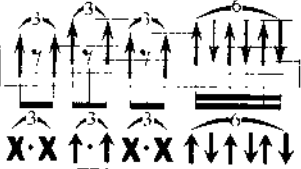
节奏	 <p>X·X ↑·↑ X·X ↑·↑</p>	 <p>X·X ↑·↑ X·X ↑·↑</p>
----	--	---

不同于Swing切分的感觉，Shuffle 是把三连音中，第二个音的拍点休止不弹，所造成顿挫有力的节奏型态，亦是蓝调音乐中不可或缺的元素之一。

一般Shuffle的记谱方式习惯以  $\text{♩} = \text{♩}$  来表示。这样一来谱上只要出现Shuffle的感觉就可以不需加注三连音的记号了。这种记号通常会加注在乐谱的上方，只要看到这种记号，所有的乐手都必须演奏出这种拍子，当然也包括主唱在内。

## 浪人情歌

词 / 吴俊霖 曲 / 吴俊霖 演唱 / 吴俊霖

Key: Gm Play: Em Capo: 4 Tempo: 4/4 Rhythm: Slow Rock Picking:  $\overset{3}{xxx}\overset{3}{\uparrow\uparrow}\overset{3}{xxx}\overset{3}{\uparrow\uparrow}$ 

Em Em Em

0 0  $\overset{3}{023}$  5i | 6  $\overset{3}{2321}$  0  $\overset{3}{261}$  6 0  $\overset{3}{023}$  5i 6 —  $\overset{3}{0321}$   $\overset{3}{231}$

Em Em Em Em

$\overset{3}{216}$  6 —  $\overset{3}{123}$  |  $\overset{3}{653}$   $\overset{3}{321}$   $\overset{3}{216}$   $\overset{3}{653}$   $\overset{3}{532}$   $\overset{3}{321}$   $\overset{3}{216}$   $\overset{3}{165}$   $\overset{3}{653}$   $\overset{3}{532}$   $\overset{3}{321}$   $\overset{3}{216}$

Em Am7 Em G D/F# Em

0  $\overset{3}{665}$  6i — | 0  $\overset{3}{221}$   $\overset{3}{26}$   $\overset{3}{612}$   $\overset{3}{33}$   $\overset{3}{33}$   $\overset{3}{32}$   $\overset{3}{221}$  2.6  $\overset{3}{665}$  6  $\overset{3}{012}$

不要再想你 不要再爱你 让时间悄悄地飞逝 抹去我俩的回忆 对于  
让他随风去 让他无痕迹 所有快乐悲伤 通通都抛去心中

G D Em Am7 D

$\overset{3}{33}$   $\overset{3}{332}$  2  $\overset{3}{25}$  |  $\overset{3}{63}$   $\overset{3}{332}$  3  $\overset{3}{321}$   $\overset{3}{232}$  2 —  $\overset{3}{116}$   $\overset{3}{1655}$  0 0 :

你的名字从今不会再提起 不再让悲伤 将我心占据  
想的念的盼的 望的 不会 再是你 不愿再

Am7 D G C G

$\overset{3}{23}$   $\overset{3}{22}$  —  $\overset{3}{116}$   $\overset{3}{2111}$  — 0 0  $\overset{3}{66}$   $\overset{3}{66}$   $\overset{3}{653}$  |  $\overset{3}{65}$   $\overset{3}{553}$   $\overset{3}{65}$  5

承受 要把你忘记 我会擦去 我不小心滴下的泪水

C G C D/F# Em

0  $\overset{3}{66}$   $\overset{3}{66}$   $\overset{3}{653}$   $\overset{3}{65}$   $\overset{3}{53}$  5  $\overset{3}{035}$  6  $\overset{3}{66}$   $\overset{3}{77}$   $\overset{3}{75}$  i 7 6  $\overset{3}{321}$

还会装做一切 都无所谓 将你和我的爱情全部敲碎 再将他



Am7 D Em Am7 Fm

2 2 2 1 2 6 6 6 3 6 5 5 6 6 5 - | 0 6 6 5 6 1 1 | 0 2 2 1 2 6 6 1 2 |

通通 赶 出我 受伤的 心 扉 让他随 风去 让他无 痕迹 所有

G D#F Em G D Em

3 3 3 3 2 2 2 2 1 2 6 6 6 5 6 0 1 2 3 3 3 3 2 2 2 5 | 6 3 3 3 2 3 3 2 1

快乐 悲伤 所有 过去 通通 都抛 去 心中 想的 念的 盼的 望的 不会 再是 你 不愿再

Am7 D G D#F Em Am7 Em

2 3 2 2 1 1 6 2 1 1 1 - 7 | 6 6 6 5 6 1 1 | 0 2 2 1 2 6 0 1 2 |

承 受 要 把你 忘 记 啊... **G.T.solo**

G D#F Em G D#F Em

3 5 5 3 2 5 5 2 1 5 5 1 6 0 1 2 3 5 5 3 2 5 5 5 | 6 3 3 3 2 3 3 2 1

Am7 D G

2 3 2 2 - 1 1 6 1 2 1 1 - - - |

Am7 D G Am7 D G

2 3 2 2 - 1 1 6 2 1 1 1 - 3 2 1 2 3 2 2 - 1 1 6 2 1 1 1 - 3 2 1 |

承 受 要 把你 忘 记 不 愿再 承 受 我 把你 忘 记 你 会看

Am7 D G D#F Em Em

2 3 2 2 - 0 1 6 2 1 1 1 - 7 6 - - 0 0 0 0 0

见 的 把 你 忘 记 啊.....

Em Em Em Em Em

0 0 0 0 0 0 0 0 0 0 0 0 | 0 0 0 0

(口白) 我想到了一个忘记温柔的你的方法我不要再想你,不要再爱你,不会再提起你



弹指之间

Em                      Em                      Em                      Em



0 0 0 0    0 0 0 0    0 0 0 0    0 0 0 0

我的生命中不曾有你

Fine



### 先行音 (拍)

在乐句中，使用下一个和弦的一个音或数个音，预先出现在本和弦当中，而使得下一个和弦很容易可以预知的方法，这些预先出现的音，就叫做「先行音」。如果出现在节奏上就叫它「先行拍」。

先行拍    | —    7  || / / / / / / /

先行音    | 0 0 0  || 1 23 1 23 |



























# 新不了情

词/黄郁曲/鲍比达 演唱/万芳

Key F Play C Capo 5 Tempo 4/4, = 64

Fingers |  $\overset{1}{T} \overset{2}{1} \overset{3}{2} \overset{1}{T} \overset{2}{1} \overset{3}{2} \overset{1}{T}$  |  
Picking |  $\overset{3}{XXX} \uparrow \uparrow \downarrow \uparrow \overset{3}{XXX} \uparrow \uparrow \downarrow \uparrow$  |

Fmaj7 	Em 	Dm7 	G 
3 6 - $\overset{3}{0} \overset{2}{7} \overset{1}{1}$	2 5 - $\overset{3}{0} \overset{2}{6} \overset{1}{7}$	1 4 - $\overset{3}{1} \overset{2}{7} \overset{1}{6}$	5 - - $\overset{3}{3} \overset{2}{2} \overset{1}{1}$
			心若倦
C 	Em 	Fmaj7 	Em 
3 - - $\overset{3}{3} \overset{2}{2} \overset{1}{1}$	7 - - $\overset{3}{0} \overset{2}{7}$	6 $\overset{3}{0} \overset{2}{\cdot} \overset{1}{6}$ 6 $\overset{3}{6} \overset{2}{5} \overset{1}{3}$	5 - $\overset{3}{5} \overset{2}{7} \overset{1}{1}$
了	泪也干	了	这份深情难舍难
			了 曾经拥
Dm7 	Em 	Am 	Fmaj7 
4 - - $\overset{3}{2} \overset{2}{6} \overset{1}{7}$	5 - - $\overset{3}{5} \overset{2}{4} \overset{1}{3}$	6 - - $\overset{3}{6} \overset{2}{5} \overset{1}{4}$	3 - 2 $\overset{3}{3} \overset{2}{2} \overset{1}{1}$
有	天荒地老	已不见	你 暮暮与朝朝 这一份
C 	Em 	Fmaj7 	Em 
3 - - $\overset{3}{3} \overset{2}{2} \overset{1}{1}$	7 - - $\overset{3}{0} \overset{2}{7} \overset{1}{1}$	6 $\overset{3}{0} \overset{2}{\cdot} \overset{1}{6}$ 6 $\overset{3}{6} \overset{2}{5} \overset{1}{3}$	5 - - $\overset{3}{5} \overset{2}{7} \overset{1}{1}$
情	永远难	了 愿来	生 还能再度拥 抱 爱一个
Dm7 	G 	Fm 	Am 
4	$\overset{3}{2} \overset{2}{6} \overset{1}{7}$	5 5 $\overset{3}{\cdot} \overset{2}{2}$ 1 $\overset{3}{6} \overset{2}{7} \overset{1}{1}$	1 $\overset{3}{1} \overset{2}{\cdot} \overset{1}{4}$ 4 $\overset{3}{6} \overset{2}{7} \overset{1}{1}$ 2 - 5
人	如何厮	守 到老 怎样面	对 一切 我不知 道 回
Fmaj7 	Em 	Am 	Dm7 
3 $\overset{3}{3}$ $\overset{3}{6} \overset{2}{6}$ 6 $\overset{3}{6} \overset{2}{7} \overset{1}{1}$	2 3 2 5 1 1	0 6 7	1 $\overset{3}{1} \overset{2}{\cdot} \overset{1}{4}$ 4 $\overset{3}{1} \overset{2}{7} \overset{1}{6}$   $\overset{3}{6} \overset{2}{5}$ 5 $\overset{3}{4} \overset{2}{\cdot} \overset{1}{3}$ 3 5
忆 过去 痛苦的	相思忘不了	为何	你 还来 拨动我 心跳 爱你 怎



Fmaj7



3 6 6 6 - 3 2 1

么能了

Fmaj7



6 - - 6 5 4

(Sax Solo)

Fmaj7



1 7 7 6 6 6 5 5

Em



Am



2 5 5 5 2 1 1 0 6 7

你应该明了缘难

Em



Am



7 5 5 5 3 3 6 3 5 5

Dm7



G



1. 1. 1. 0 6 7

了情难了

Dm7



G



0 5 5 4 3 3 3 2

C



1 - - -

了

C



C7



6 7 6 5 5 - 5 1

Fmaj7



1 7 7 6 6 6 5 5

Em



A7



6 5 5 3 6 6 -

Dm7



0 6 6 4 4 3 3 4 5

G



2 - - 3 2 1 :

心若倦

Dm7



1 - - 0 6 7

了情难了

Dm7



1 1 4 4 1 7 6

你 还 来 拨 动 我

Dm7



1 - - 6

了情难了

C



5 1 2 1 3 3 -

C



1 - - 5

回忆过去痛苦的

C



C7



6 5 5 4 3 3 5 3

Fmaj7



3 3 6 6 6 6 7 1

回忆过去痛苦的

Fmaj7



3 6 6 6 - 3 2 1

了情难了

C



1 - - -

了

C



6 3 5 3 1 6

Em



2 3 2 5 1 1 0 6 7

相思忘不了为何

Em



Am



2 5 5 5 2 1 1 0 6 7

你应该明了缘难

Fmaj7



5 4 1 1 -

(Sax Solo)

C



2 6 1 1 0

Fine



## 痛哭的人

词/吴俊霖 曲/吴俊霖 演唱/吴俊霖

Key Em · Play Em · Tempo 4/4 ♩ = 60 ♩ Rhythm Slow Rock · Picking | xxx↑↑↑xxx↑↑↑↑↑



Em



0 0 0 0



G

0 0 0 0



D

0 0 0 0

## Acoustic Chord



C

0 0 0 0



Em

6 3 2 5



G

6 3 2 3 5 3 2 1

## Syn.



D

2 3 2 3 2 7



C

1 6 6 5 6 -



Em

6 3 2 5



G

6 3 2 3 5 3 2 1



D

2 3 2 3 2 7



C

1 6 6 5 6 - ||



Em

6 6 5 6 6 7 1 1 2 3

今夜的寒风将我心撕碎



G

3 2 2 2 1 5 1 1 2 3

仓惶的脚步我不醉不归



D

2 2 2 2 3 2 2 2 1 2

朦胧的细雨有朦胧的美



C

1 6 6 6 5 1 -

酒再来一杯



Em

6 6 5 6 6 7 1 1 2 3

爱上你从来就不曾后悔



G

3 2 2 2 1 5 1 1 2 3

离开你之后是宿命的醉



D

2 2 2 2 3 2 2 2 1 2

刺鼻的酒味我浑身欲裂



C

1 6 6 6 6 5 1 -

嘶哑着我的眼泪



Em

6 6 6 6 7 6 6 6 6 6

我怎么哭的如此狼狈







5 3 3 3 2 1 1 1 2 3  
是否我 对你还 有些依 恋



6 6 6 6 7 6 6 6 6 6  
我怎么 哭的 如此狼 狈



1 6 6 6 6 5 1 6 6 5  
肤浅而 恍然的 我 痛哭的



2 3 2 3 2 7 1 6 6 5 6



6 - - 1 6 5 6 - - 1 6 5  
人 痛哭的 人 痛哭的

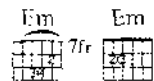

6 0 0 0

啊



0 0 0 0

啊



5 6 6 5 5 2 5 6 6 5 5 2  
一到 了尽头 无法 再回头



5 3 3 3 2 1 1 5 2 3  
是否我 还期待 你的出 现



6 3 2 5 6 3 2 3 5 3 2 1  
人 Syn.



1 6 6 5 6 - - 1 6 5



6 - - 1 6 5 6 - - 1 6 5  
人 痛哭的 人 痛哭的



0 0 0 0

啊



4 - - 4 3 2

啊 爱或者



1 6 6 6 6 5 1 -  
我不是 全都想 过



5 6 6 5 5 2 5 6 6 5 5 2  
无法 再相信 相信 我自己



6 3 2 3 5 3 2 1  
人



6 - - 1 6 5  
人 痛哭的



1 6 5 1 6 5 1 6 5 6 6 6  
痛哭的 痛哭的 痛哭的 啊啊啊



0 0 0 0

啊



3 6 - -

不 爱



Am



Em



Am



4 3 4 4 3 4 | 5 6 5 3 3 3 - | 4 3 4 4 3 2

我 已 经 无 法 分 辨 要 如 何 才 能 够

Em



G



Em



3 1 1 1 - 0 6 | 1 1 1 1 2 6 - - -

忘 记 我 曾 许 下 的 诺 言

Em



G



D



6 6 5 6 6 7 1 1 2 3 | 3 2 2 2 1 5 1 1 2 3 | 2 2 2 2 3 2 5 5 5 6 5

今 夜 的 寒 风 将 我 心 撕 碎 仓 惶 的 脚 步 我 不 醉 不 归 朦 胧 的 细 雨 有 朦 胧 的 美

C



Em



1 6 6 6 5 6 6 5 2 | 3 - - -

酒 再 来 一 杯 痛 哭 的 人

**Fine**



# 21 Guitar 音乐类型【五】

## 16 Beat 灵魂乐

### Soul (16 Beat)

有别于 Slow Soul 的伴奏方式，因其在每一小节内有 16 个拍点，相当于 Slow Soul 的二倍拍点，所以我们用 16 Beat 或 Double Soul 来称之。

一般 16 Beat 的速度也会比 Slow Soul 来得轻快些，练习使用节拍器速度控制在 ♩ = 90 以上，最能表现此节奏特色。

#### 指法

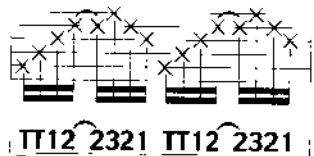
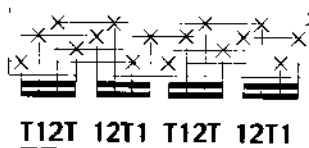

#### 节奏

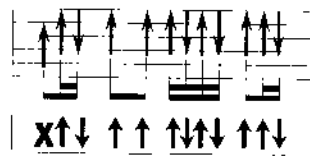
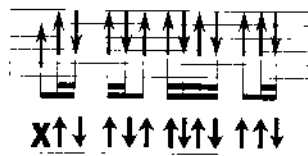

#### 加入切音后而形成“Disco”节奏

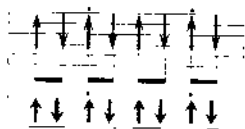

## 分手吧

词/张磊岳 曲/张磊岳 演唱/张磊岳

Key G Play G Tempo 4/4 = 96 Rhythm Soul Picking | x↑↓ ↑↑ ↑x ↑↓ |

0 0 0 0 | 0 0 0 0 | 3 3 3 2 1 2 3 2 3 3 - |

写一封没有地址的信

Em C G G#F

0 0 3 5 4 3 4 3 1 1 - 0 | 3 3 3 2 1 1 2 3 2 3 3 - |

想寄到你的心里 告诉你渐渐变淡的爱

Em C Am Em

0 0 3 5 4 3 4 3 1 1 - 0 | 0 4 4 4 4 3 1 1 | 3 2 2 1 1 - |

你是否曾经注意 过去的美丽 已经不在

Am Em Am Em

0 4 4 4 4 3 4 6 6 3 3 - 0 | 0 4 4 4 4 3 1 1 | 3 2 3 1 1 - |

我还在傻傻后找寻 也许你想要说但说不出口

Am G D#F

0 4 4 4 4 3 1 2 2 - - 0 | 1 7 7 5 5 5 5 3 1 7 7 5 5 1 1 6

我知道你想说 分手吧 我们分手吧 不要再

Em C G

3 2 2 1 1 7 5 6 5 5 5 5 5 6 6 6 6 5 3 1 1 - 0 5 5 5

骗我说你还爱着我 你我的梦 彼此都不同 就算是

A D D Em/C































1. 2.

6 6 6 6 6 6 6 5 5 5 - 0 | 5 - 6 6 3 2 | 1 2 1 1 - - |





当做一时糊涂爱错 喔 我们



弹指之间





Am 	D 	G 	G/F 	Em 
0 0	<u>3</u> · <u>2</u> <u>2</u> 1	1 -	0 0 0 0	0 0 0 0
分手吧				
C 	G 	G/F 	Em 	
0 0 0 0	0 0 0 0	0 0 0 0	0 0 0 0	
C 				
0 0 0 0				
G 	D#F 	Em 	D 	
3 · <u>4</u> 4	5 2 · <u>3</u> 3	4 1 · <u>2</u> 2	3	<u>3 2</u> <u>2 1</u> <u>6 7</u> <u>6 5</u>
<b>G.T. Solo</b>				
C 	G 	A 	D 	
6 · <u>7</u> 7	i 5 · <u>7</u> 7	i #4 · <u>7</u> 7	i	5 4 4 3
G 	D#F 	Em 	D 	
3 · <u>4</u> 4	5 2 · <u>3</u> 3	4 1 · <u>2</u> 2	3	<u>3 2</u> <u>2 1</u> <u>6 7</u> <u>6 5</u>
C 	G 	A 	D 	
6 · <u>7</u> 7	i 5 · <u>7</u> 7	i #4 · <u>7</u> 7	i	5 · <u>6</u> 6 5
G 	D#F 	Em 	D 	
: <u>1</u> · <u>7</u> 7 5	<u>5</u> 5 <u>5</u> 3	<u>1</u> · <u>7</u> 7 5	<u>5</u> 1 <u>1</u> 6	<u>3 2</u> <u>2 1</u> <u>1 7</u> <u>5 6</u>
分手吧 我们	分手吧 不要再	骗我说你	还爱着我	5 · <u>5</u> <u>5</u> 5 <u>5</u> 6
				你 我的梦



6 · 6 6 5 3 1 | 1 - 0 5 5 5 | 6 6 6 6 6 6 5 5 | 5 - - 0 :||

彼此都不同 就算是 当做 一时 糊涂爱 错

5 - · 6 6 3 2 | 1 2 1 1 - - | 0 0 3 2 2 1 | 1 - - 0 |

喔 我 们 分手吧

1. -----  
Fade Out



### 手指练习 Blues Feel

2 1 4 1 2 1 4 1    2 1 4 1 2 1 4 1    2 1 4 1 2 1 4 1

3 2 5 2 3 2 5 2    3 2 5 2 3 2 5 2    3 2 5 2 3 2 5 2

和弦根音

2 1 4 1 2 1 4 1    2 1 4 1 2 1 4 1    2 1 4 1 4 4 2 1

3 2 5 2 3 2 5 2    5 4 7 4 3 2 5 2    3 2 5 2 5 5 3 2 0

注：1 2 3 4 表手指代号，可依次选择任意琴格来作练习。



# 可以爱你真好

美丽佳人GIORDANO蓝丝带活动主题曲

词/徐世珍 曲/张佳添 演唱/蔡健雅



D

Key



D

Play



4/4 = 90

Tempo



Slow Soul

Rhythm

D



Dmaj7



D7



G

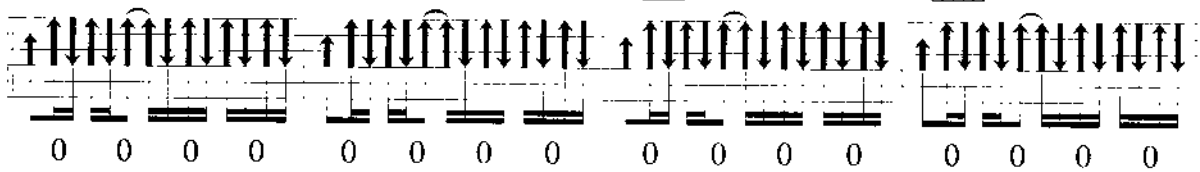

Gm



D



Dmaj7



D7

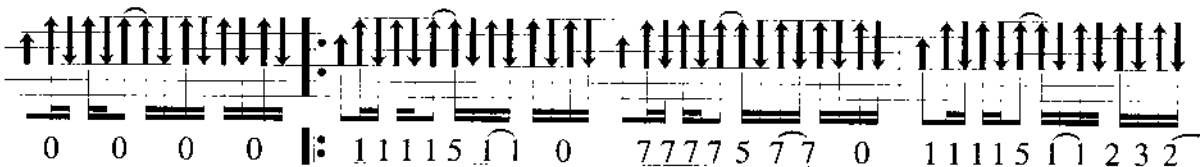

可以爱你真好

可以想你真好

可以被你拥抱 想起你

G



Gm



D



Dmaj7



的微笑 就是 会心跳

可以爱你真好

可以想你真好









# 22 音乐类型【六】 跑马式的节奏

跑马式的节奏，多用于节奏感较强的歌曲中。这种节奏多半须搭配Pick来使用，来增加节奏上的气势。若习惯使用手指，亦可以使用小指，无名指与食指快速地来回，来达到此种效果。

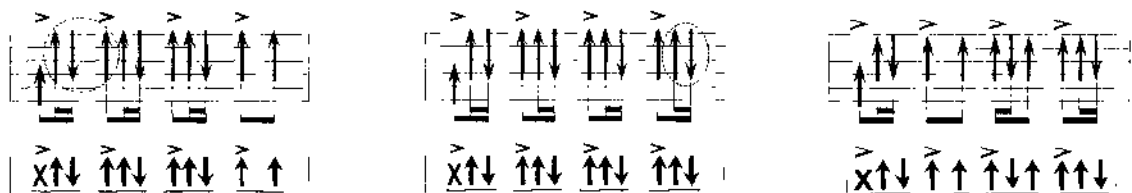

跑马式的连音弹奏方式，常被搭配在Folk Rock与Slow Soul节奏中来使用。

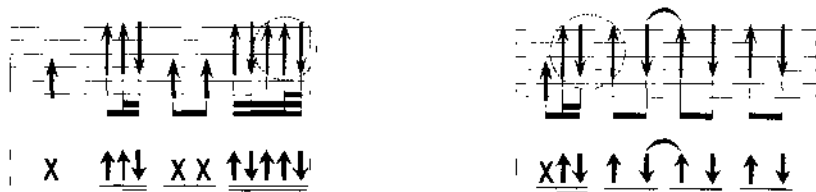

## 弹奏要点：

弹奏时请多增加手腕的摆动，来达到连音的效果。由于连音速度快，所以建议使用较软质的Pick，可以得到省力又清脆的声音喔！



# 旷野寄情

词/靳铁章 曲/靳铁章 演唱/李健复



Gm



Em



3



4/4



↑↑↓↑↑↑↓↑↑↓

Em



Musical notation for the first system, including a guitar staff with fret numbers and a bass line with rhythmic notation.

(Free Temple 自由速度)

D



C





















Musical notation for the second system, including a guitar staff with fret numbers and a bass line with rhythmic notation.

Em



Musical notation for the third system, including a guitar staff with fret numbers and a bass line with rhythmic notation.



<p>Em</p>  <p>0 <math>\dot{1} \dot{1} \dot{1}</math> 2   <math>\dot{3} \dot{3} \dot{3} \dot{4} \dot{3} \dot{2}</math> <math>\dot{1}</math>  </p> <p>我又回到相遇的地方</p>	<p>D</p>  <p>0 7 7 7 <math>\dot{1}</math>   <math>\dot{2} \dot{2} \dot{3} \dot{3} \dot{2}</math> <math>\dot{1} \dot{7}</math> 2  </p> <p>一个空旷凄清的地方</p>
<p>C</p>  <p>0 <math>\dot{1}</math> 6 6 6 7   <math>\dot{1} \dot{2} \dot{2} \dot{1}</math> 7 6  </p> <p>让北风从我脸上吹掠</p>	<p>B7</p>  <p>0 <math>\#5 \#5 \#5</math> 6   7 3 3 <math>\dot{2} \dot{3} \dot{2}</math>  </p> <p>我的心也随风飞翔</p>
<p>Em</p>  <p>0 <math>\dot{1} \dot{1} \dot{1}</math> 2   <math>\dot{3} \dot{3} \dot{3} \dot{4} \dot{3} \dot{2}</math> <math>\dot{1}</math>  </p> <p>我又听到熟悉的音响</p>	<p>D</p>  <p>0 7 7 7 <math>\dot{1}</math>   <math>\dot{2} \dot{2} \dot{3} \dot{3} \dot{2}</math> <math>\dot{1} \dot{7}</math> 2  </p> <p>一种温柔原始的奔放</p>
<p>C</p>  <p>0 <math>\dot{1}</math> 6 6 6 7   <math>\dot{1} \dot{2} \dot{2} \dot{1}</math> 7 6  </p> <p>劈拍拍弦声在山谷回响</p>	<p>B7</p>  <p>0 <math>\#5</math> 6 7   3 2 <math>\dot{1} \dot{7}</math> 7  </p> <p>我的心也随之荡</p>
<p>Em</p>  <p>6 - - - - <math>\dot{6}</math> - - - -</p> <p>漾</p>	<p>D</p>  <p>0 7 7 7   <math>\dot{1}</math> 6 6 <math>\dot{1}</math>  </p> <p>千里冷月伴星</p>
<p>B7</p>  <p>7 - - - <math>\dot{1} \dot{7} \dot{6}</math>   7 - - -</p> <p>光</p>	<p>C</p>  <p>0 6 7 <math>\dot{1}</math>   2 <math>\dot{1}</math> - 2  </p> <p>但我的歌声高</p>
<p>Em</p>  <p>3 - - - - <math>\dot{3}</math> - <math>\dot{3} \dot{4} \dot{4} \dot{3}</math>   <math>\dot{2} \dot{1} \dot{2} \dot{2}</math> - - <math>\dot{2}</math> - <math>\dot{2} \dot{3} \dot{3} \dot{2}</math>  </p> <p>亢 啊 啊</p>	<p>D</p>  <p><math>\dot{2} \dot{1} \dot{2} \dot{2}</math> - - <math>\dot{2}</math> - <math>\dot{2} \dot{3} \dot{3} \dot{2}</math>  </p>
<p>C</p>  <p><math>\dot{1} \dot{7} \dot{1} \dot{1}</math> - -   <math>\dot{6} \dot{7} \dot{1} \dot{2} \dot{2}</math> <math>\dot{1}</math>   <math>\dot{7} \dot{6} \dot{7} \dot{7}</math> - - <math>\dot{7}</math> - <math>\dot{6} \dot{5}</math>  </p> <p>啊 高</p>	<p>B7</p>  <p><math>\dot{7} \dot{6} \dot{7} \dot{7}</math> - - <math>\dot{7}</math> - <math>\dot{6} \dot{5}</math>  </p>
<p>Em</p>  <p>6 - - - - <math>\dot{6}</math> - - - -</p> <p>亢</p>	<p>C</p>  <p>0 0 0 0   0 0 0 0  </p> <p>(Em 调音阶自由发挥)</p>



D C B7



0 0 0 0 | 0 0 0 0 | 0 0 0 0 0 0 0 0

Em Em

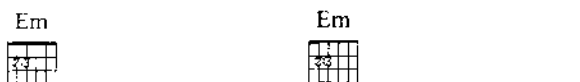

0 0 0 0 | 0 0 0 0 :|

B7



0 #5 6 7 3 2 1 7 7 : 6 - - - 6 - - -

我 的 心 也 随 之 荡 漾

Em D

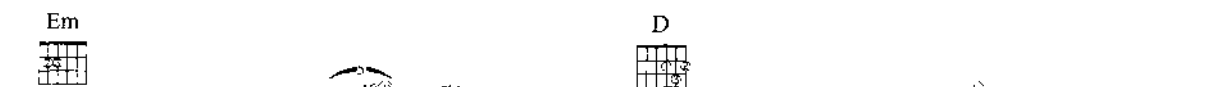

5 5 5 7 8 5 7 8 7 5 7 5 8 7 5 5 5 - 7 8 8 10 10 10 10 10 10

0 0 0 6 6 6 7 1 2 3 4 3 2 3 2 1 7 6 6 - | 0 0 0 5 5 5 6 7 1 2 3 4 4 5 5 5 5 5 5

C B7

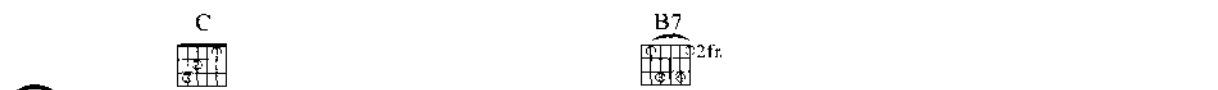

10 10 8 7 5 8 3 7 5 8 7 5 5 7 8 8 - 2 2 2 4 2 4 2 4 5 7 7 4 4

0 0 0 4 3 2 1 | 4 3 2 1 7 6 6 7 1 1 | 0 3 3 3 #4 5 6 7 2 3 #4 5 6 7 - #5 - -

Em



6 - - - -

Fine



## 凡人歌

词/李宗盛 曲/李宗盛 演唱/李宗盛



Key Dm

Play Dm

Tempo 4/4, = 118

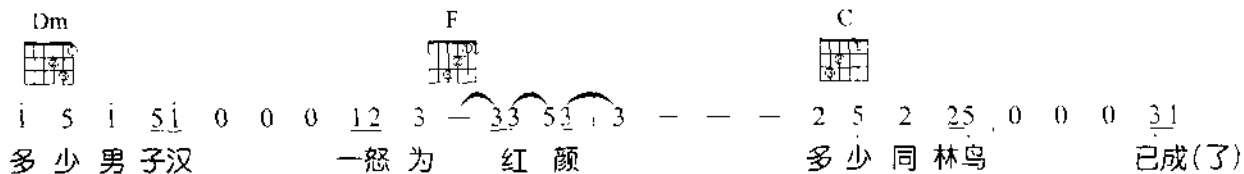
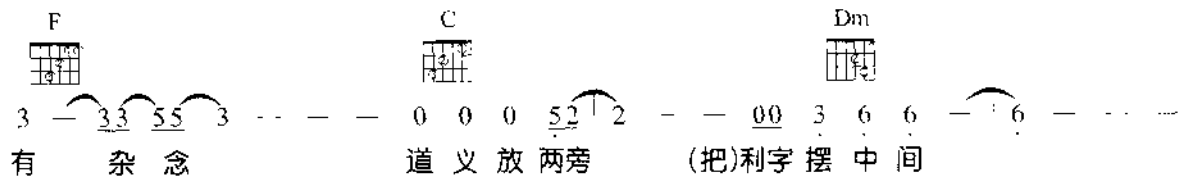
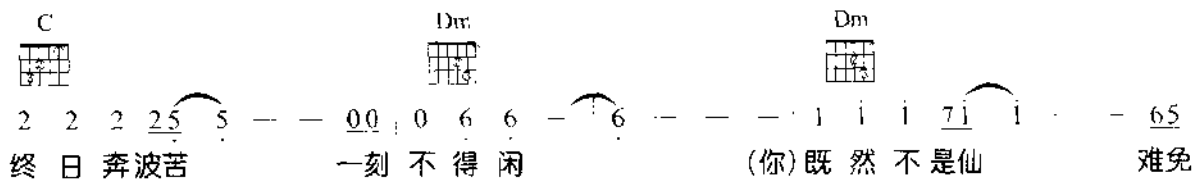
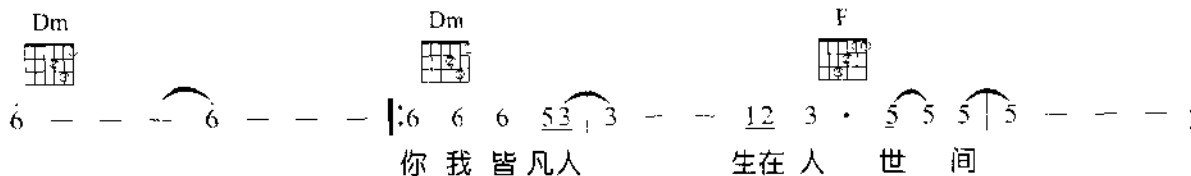
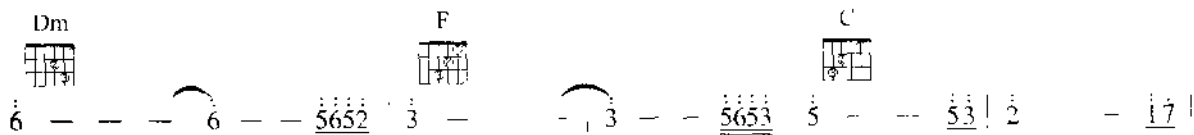
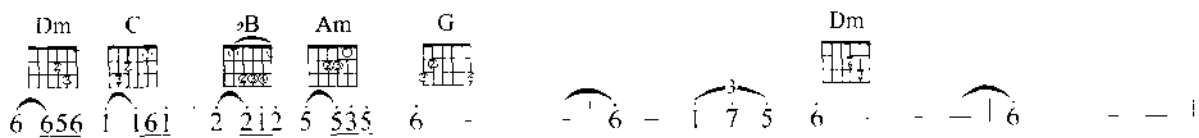



Picking | X↑↓↑↑↑↓↑↑↓ |



Dm  Dm  F 







1 1 16 6 6 — — — | 1 1 1 73 3 — — | 12 | 3 — 33 55 3 — — — |

分飞燕 人生何其短 何必苦苦恋

C  Dm  Dm  F 













2 2 2 25 | 5 — — | 17 1 3 6 — 6 — — — || 66 6 06 61 33 53 0 21 |

爱人不见了 向谁去喊冤 问你何时曾看见 这世





C  Dm  Dm  F  C  Dm 

2 2 2 27 5 6 — — — | 066 66 66 65 66 16 0 31 | 2 2 2 17 5 6 — — — |













界为了人们改变 有了梦寐以求的容颜 是否就算是拥有春天

$\flat B$   C  F  C   $\flat B$   C  Dm  A7   $\flat B$   C  F  C 





6 - 5 - 3 - 2 - 6 · | 76 52 3 - — — | 6 - 5 - 32 1 2 - |

$\flat B$   Am  Dm  Dm 

1 - — — | 7 6 5 3 6 - — — | 6 - — — | 6 - — — | 6 - — — |

$\flat B$   C  F  C   $\flat B$   C  Dm  A7   $\flat B$   C  F  C 

6 - 5 - | 32 1 2 - 6 - 5 - 32 12 3 - 6 · | 7 5 3 | 13 2 -

$\flat B$   Am  Dm  Dm 

1 - 17 61 | 7 5 3 - 6 - — — | 6 - — — | 6 - — — | 6 - — — | 6 - 17 5

6 - — — | 6 - — — —  
 Fine



# 23 根音与经过音的 变化与填充

一般来说，我们在弹奏和弦时，多以其主音为根音来弹奏。但是这样的弹奏方式，显得过于呆板，基本上以三和弦来说，C（1、3、5）之中，1为主根音，3、5我们称之为副根音，在观念上，三和弦的每一个内音，均可当作其根音来使用（转位和弦）。所以在弹奏时，可使用三度根音变换或五度根音变换方法。

在两个和弦根音之间，加入第三音，来当做连接这两个和弦之间的桥梁，这种音的填充，我们称之为过门音（经过音）。

经过音的填充可分：

1. 上行音阶的填充（1 2 3 4 5 6 7  $\dot{1}$ ）
2. 下行音阶的填充（ $\dot{1}$  7 6 5 4 3 2 1）

至于选择上行或下行音阶，则视前后和弦根音的音程差异，一般我们会选择较近的音程组合，如C至G和弦，经过音常使用（1 7 6 5）而不使用（1 2 3 4 5）。

▶ 范例一 》 Slow Soul Style

C                      Am                      F                      G7

1 — — 1 7 6 — — 6 5 | 4 — — 4  $b5$  | 5 — — 6 7 :





▶ 范例二 《 Rumba Style

G Em Am D7

1 — 3 5 6 — 1 3 2 — 4 6 5 — 5 4 3 2 :|

▶ 范例三 《 Folk Style

C F

1 — 5 — 1 — 2 3 4 — 1 — 4 — 3 2

C G

1 — 5 — 1 — 7 6 5 — 2 — 5 5 6 7 :|

▶ 范例四 《 Solw Rock Style

Em G D C

6 — — 6 6 7 1 — — 1 1 2 5 — — 6 5 3 4 — — 4 3 1 :|



# 对面的女孩看过来

词/阿牛 曲/阿牛 演唱/任贤齐



Key

C



Play

C



Tempo

4/4 ♩ = 130



Rhythm

Trot

Chord diagrams for C major (x02321) and guitar notation for the first line of the piece.

Chord diagrams for C, G, Am, and Em, along with the first line of lyrics and guitar notation.

对 面的 女 孩 看 过 来 看 过 来 看 过 来  
对 面 的 女 孩 看 的 过 来 看 说 出 来 看 谁 过 明 白

Chord diagrams for F, C, Am, Dm, and G, along with the second line of lyrics and guitar notation.

6 6 6 5 4 5 5 6 1 2 2 2 1 2 6 3 6 5  
这 不 求 里 的 被 你 表 我 抛 演 的 个 很 样 精 子 吓 彩 坏 来 请 其 哄 不 要 假 装 不 理 不 可 开 睬 爱 怀



弹指之间

G G G

0 0 0 0 | 0 0 0 0 | 0 0 0 0

(没人理我)

C CB Em Am F

0 0 0 0 1 | 1 5 5 7 | 7 2 2 1 | 6 1 1 1 6 1 1 1

我 左 看 右 看 上 看 下 看 原 来 每 个 女 孩 都

G C CB Am Am7/G F

3 2 1 2 2 0 1 | 1 5 5 5 7 7 7 | 7 2 2 2 1 1 | 6 1 1 1 6 1 1 1

不 简 单 我 想 了 又 想 我 猜 了 又 猜 女 孩 们 的 心 事 还

G C CB Am Am7/G F

3 2 1 5 5 0 1 | 2 3 3 5 5 1 | 2 3 3 5 5 6 6 | 3 1 1 1 1 6 1

真 奇 怪 (口琴)

G C CB Am Am7/G F

2 1 5 - 0 1 | 2 3 3 5 5 1 | 2 3 3 5 5 6 6 | 3 2 1 1 1 6 1



G G C G

i - 7 2 5 5 - - - | 1 1 1 1 1 2 2 3 2 -

寂 寞 男 孩 的 苍 蝇 拍

Am Em F C Am

1 1 i - 7 6 5 - 6 6 6 5 4 5 5 5 6 1 -

左 拍 拍 右 拍 拍 为 什 么 还 是 没 人 来 爱

Dm G G C

2 2 2 3 2 - 6 3 6 5 - - - 0 0 | 1 1 1 1 1 1

无 人 问 津 真 无 奈 对 面 的 女 孩

G Am Em F

2 2 2 3 2 - 1 1 i - 7 6 5 - 6 6 5 4

看 过 来 看 过 来 看 过 来 寂 寞 男 孩

C Am Dm G G

5 5 5 6 1 - 2 2 3 2 2 1 6 3 6 5 5 5 - - -

情 窦 初 开 需 要 你 给 我 一 点 爱



G G

7 - - - 0 0 0 0

爱 %

G C C/B Em Am F

0 5 1 6 2 1 1 1 1 2 2 2 7 7 7 1 1 1 1 1 1 1 1 1 1 1

爱 真 奇 怪 来来... 来来... 来来...

G C C/B Em Am F

2 5 3 2 2 - 1 1 1 2 2 2 2 2 7 7 7 1 1 1 1 1 1 1 1 1 1 1

喔 耶喔 来来... 来来... 来来...

G G G G

2 - - - 0 0 0 0 0 0 0 0 0 0 0 0

喔 (唉!算了!回家吧!) Fine



# 24 | 三和弦与七和弦 Guitar 的组成

有一天学生问我说！老师，我们弹的是一样的和弦，为甚么感觉会不一样呢？我便告诉他：因为我学过乐理啊！他又接着问！为甚么乐理跟和弦会有关系呢？我楞了一下...，回答他，因为和弦跟乐理有关系啊，喔！他便摸着头离开了。你认为呢？

一般人会把乐理这个东西想的太深奥了，不过！我只想用最简单的方式告诉你。

## 一、音程

在音阶中，音与音之间相差的距离（五线谱上的高度差）我们称之为「音程」。在乐理上我们习惯以「度」来做为计算音程的单位。

音程名称	音程差	半音数	Example
完全一度 <i>Unison</i>	等音之两音	0	1 → 1
小二度 <i>Minor Second</i>	两音相差一个半音	1	1 → $^b2$
大二度 <i>Major Second</i>	两音相差一个全音	2	1 → 2
小三度 <i>Minor Third</i>	两音相差一个全音又一个半音	3	3 → 5
大三度 <i>Major Third</i>	两音相差二个全音	4	5 → 7
完全四度 <i>Perfect Fourth</i>	两音相差二个全音又一个半音	5	1 → 4
增四度 <i>Augmented Fourth</i>	两音相差三个全音	6	4 → 7
减五度 <i>Diminished Fifth</i>	两音相差三个全音	6	7 → 4
完全五度 <i>Perect Fifth</i>	两音相差三个全音又一个半音	7	1 → 5
小六度 <i>Minor Sixth</i>	两音相差四个全音	8	1 → $^b6$
大六度 <i>Major Sixth</i>	两音相差四个全音又一个半音	9	1 → 6
小七度 <i>Minor Seventh</i>	两音相差五个全音	10	1 → $^b7$
大七度 <i>Major Seventh</i>	两音相差五个全音又一个半音	11	1 → 7
完全八度 <i>Octave</i>	两音相差六个全音	12	1 → $\dot{1}$
小九度 <i>Minor Ninth</i>	两音相差六个全音又一个半音	13	$\dot{7}$ → $\dot{1}$
大九度 <i>Major Ninth</i>	两音相差七个全音	14	1 → $\dot{2}$
小十度 <i>Minor Tenth</i>	两音相差七个全音又一个半音	15	$\dot{6}$ → $\dot{1}$
大十度 <i>Major Tenth</i>	两音相差八个全音	16	1 → $\dot{3}$



在上表中大家要特别注意音程的计算方式，举个例子来说，1(Do)与 $\flat 3$ (降Mi)是一个小三度音程，在五线谱上的高度为两线之间的距离，只不过在3(Mi)前加了一个降记号，再看1(Do)与 $\sharp 2$ (升Re)，表面上 $\flat 3$ (降Mi)与 $\sharp 2$ (升Re)两音是相同的，只是称呼不同，但是在五线谱上的高度却是不一样的，所以 $\flat 3$ 再某些特定的场合是不等于 $\sharp 2$ 的(同音异名)，一定要有这个观念，你才能打破乐理的迷思！OK！

## 二、和弦的组成

### (一) 三和弦(组成音有三个)

#### 1.大三和弦 (major)

大三和弦 = 主音 + 大三度 + 小三度

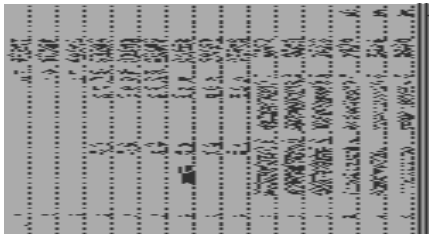

#### 2.小三和弦 (minor)

小三和弦 = 主音 + 小三度 + 大三度

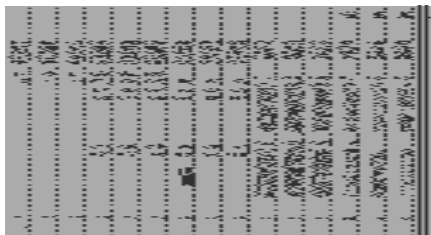

所以依照组成音公式可得12个大调和弦

和弦	组成音
C	1 3 5
$\sharp C/\flat D$	$\flat 2$ 4 $\flat 6$
D	2 $\sharp 4$ 6
$\sharp D/\flat E$	$\flat 3$ 5 $\flat 7$
E	3 $\sharp 5$ 7
F	4 6 1
$\sharp F/\flat G$	$\sharp 4$ $\sharp 6$ $\sharp 1$
G	5 7 2
$\sharp G/\flat A$	$\flat 6$ 1 $\flat 3$
A	6 $\sharp 1$ 3
$\sharp A/\flat B$	$\flat 7$ 2 4
B	7 $\sharp 2$ $\sharp 4$

同理可得12个小三和弦

和弦	组成音
Cm	1 $\flat 3$ 5
$\sharp Cm/\flat Dm$	$\flat 2$ $\flat 4$ $\flat 6$
Dm	2 4 6
$\sharp Dm/\flat Em$	$\flat 3$ $\flat 5$ $\flat 7$
Em	3 5 7
Fm	4 $\flat 6$ 1
$\sharp Fm/\flat Gm$	$\sharp 4$ 6 $\sharp 1$
Gm	5 $\flat 7$ 2
$\sharp Gm/\flat Am$	$\flat 6$ $\flat 1$ $\flat 3$
Am	6 1 3
$\sharp Am/\flat Bm$	$\flat 7$ $\flat 2$ 4
Bm	7 2 $\sharp 4$



### 3. 增和弦 (Augment)

增和弦 = 主音 + 大三度 + 大三度

### 4. 减和弦 (Diminish)

减和弦 = 主音 + 小三度 + 小三度

请参阅本书第47章增减和弦

## (二) 七和弦 (组成音有四个)

### 1. 大七和弦 (major 7)

大七和弦 = 主音 + 大三度 + 小三度 + 大三度

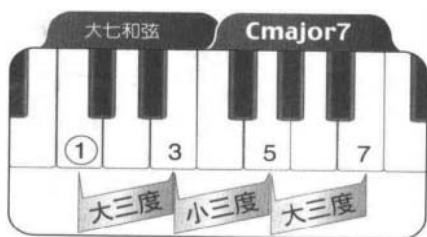

和弦	组成音
Cmaj7	1 3 5 7
$\sharp$ Cmaj7/ $\flat$ Dmaj7	$\flat$ 2 4 $\flat$ 6 1
Dmaj7	2 $\sharp$ 4 6 $\sharp$ 1
$\sharp$ Dmaj7/ $\flat$ Emaj7	$\flat$ 3 5 $\flat$ 7 2
Emaj7	3 $\sharp$ 5 7 2
Fmaj7	4 6 1 3
$\sharp$ Fmaj7/ $\flat$ Gmaj7	$\sharp$ 4 $\sharp$ 6 $\sharp$ 1 $\sharp$ 3
Gmaj7	5 7 2 $\sharp$ 4
$\sharp$ Gmaj7/ $\flat$ Amaj7	$\flat$ 6 1 $\flat$ 3 5
Amaj7	6 $\sharp$ 1 3 $\sharp$ 5
$\sharp$ Amaj7/ $\flat$ Bmaj7	$\flat$ 7 2 4 6
Bmaj7	7 $\sharp$ 2 $\sharp$ 4 $\sharp$ 6

### 2. 小七和弦 (minor 7)

小七和弦 = 主音 + 小三度 + 大三度 + 小三度

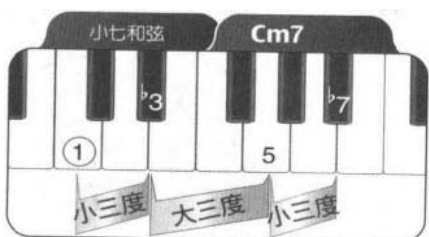

和弦	组成音
Cm7	1 $\flat$ 3 5 $\flat$ 7
$\sharp$ Cm7/ $\flat$ Dm7	$\flat$ 2 $\flat$ 4 $\flat$ 6 $\flat$ 1
Dm7	2 4 6 1
$\sharp$ Dm7/ $\flat$ Em7	$\flat$ 3 $\flat$ 5 $\flat$ 7 $\flat$ 2
Em7	3 5 7 2
Fm7	4 $\flat$ 6 1 $\flat$ 3
$\sharp$ Fm7/ $\flat$ Gm7	$\sharp$ 4 6 $\sharp$ 1 3
Gm7	5 $\flat$ 7 2 4
$\sharp$ Gm7/ $\flat$ Am7	$\flat$ 6 $\flat$ 1 $\flat$ 3 $\flat$ 5
Am7	6 1 3 5
$\sharp$ Am7/ $\flat$ Bm7	$\flat$ 7 $\flat$ 2 4 $\flat$ 6
Bm7	7 2 $\sharp$ 4 6





### 3. 属七和弦 (Dominant7)

属七和弦 = 主音 + 大三度 + 小三度 + 小三度

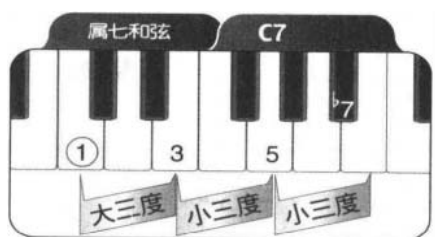

和弦	组成音
C7	1 3 5 $\flat$ 7
$\sharp$ C7/ $\flat$ D7	$\flat$ 2 4 $\flat$ 6 $\flat$ 1
D7	2 $\sharp$ 4 6 1
$\sharp$ D7/ $\flat$ E7	$\flat$ 3 5 $\flat$ 7 $\flat$ 2
E7	3 $\sharp$ 5 7 2
F7	4 6 1 $\flat$ 3
$\sharp$ F7/ $\flat$ G7	$\sharp$ 4 $\sharp$ 6 $\sharp$ 1 3
G7	5 7 2 4
$\sharp$ G7/ $\flat$ A7	$\flat$ 6 1 $\flat$ 3 $\flat$ 5
A7	6 $\sharp$ 1 3 5
$\sharp$ A7/ $\flat$ B7	$\flat$ 7 2 4 $\flat$ 6
B7	7 $\sharp$ 2 $\sharp$ 4 6

好! 下图我用流程表让你更清楚和弦的分类

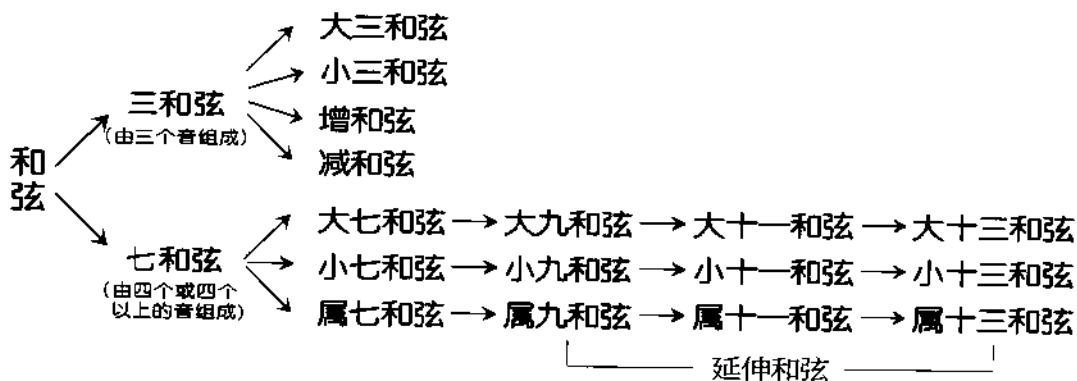

# 25 Guitar 左右手的技巧【一】

## 槌音、勾音

### 滑音与推音

#### 一、槌弦法/Hammer-on

使用右手弹弦后，左手之任一手指可在该弦上任一琴格做槌弦动作，即在同一弦上，由一较低音槌击弦至高音的动作。槌弦时，瞬间动作要快，且槌弦后手指切勿松动。

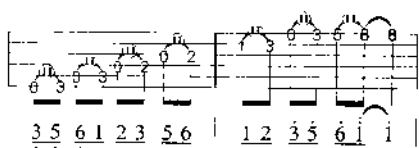

谱上记号：(H)

#### 二、勾弦法/Pull-off

使用左手之任一指按住一音，待右手弹奏该弦后，左手手指将该弦往下方勾，再放掉该弦。即在同一弦上，由一较高音勾弦至较低音的动作。勾弦时，左手手指是朝着食指的方向往下勾。



谱上记号：(P)

#### 三、滑弦法/Slide

使用左手手指按住任一音，待右手弹弦后，左手手指顺着琴格滑至另一音的琴格上，左手手指切勿离弦。



谱上记号：(S)

#### 四、推弦法/Chocking

将一个音弹奏之后，将按着的弦往上推（或往下引）而改变音程的弹奏方式，称为Chocking。又可称之为Bending。

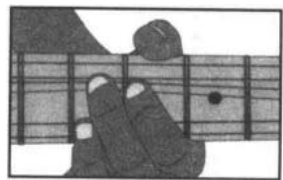

谱上记号：(C)



▶ 范例一 》 揉音练习

Am



0 3 5 6 1 2 3 5 6

1 2 3 5 6 1 1 1

Diagram showing Am chord diagram and a musical staff with notes 0, 3, 5, 6, 1, 2, 3, 5, 6 and fingerings 1, 2, 3, 5, 6, 1, 1, 1.

▶ 范例二 》 勾音练习

Am



8 5 3 2 0 2 0 3 0 5 0 6 6

1 6 5 3 2 1 6 5 3 2 1 6 5 3 6 6

Diagram showing Am chord diagram and a musical staff with notes 8, 5, 3, 2, 0, 2, 0, 3, 0, 5, 0, 6, 6 and fingerings 1, 6, 5, 3, 2, 1, 6, 5, 3, 2, 1, 6, 5, 3, 6, 6.

▶ 范例三 》 揉音加勾音练习

C



G



Am



Em



F



C



Dm7



G



C



12 12 12 10 12 0 8 10 8 7 8 7 5 7 5 3 5 3 1 3 1 1 0 0 3 4 3 2 3 2 1 2 1 7 1 7 6 7 6 5 6 5 4 5 4 3 4 3 1

Diagram showing various chord diagrams (C, G, Am, Em, F, C, Dm7, G, C) and a musical staff with notes 12, 12, 12, 10, 12, 0, 8, 10, 8, 7, 8, 7, 5, 7, 5, 3, 5, 3, 1, 3, 1, 1, 0, 0, 3, 4, 3, 2, 3, 2, 1, 2, 1, 7, 1, 7, 6, 7, 6, 5, 6, 5, 4, 5, 4, 3, 4, 3, 1.

▶ 范例四 》 滑音练习

Am



3 5 3 5 6 5 6 8 8 10 12 10 12 12 12 12

2 3 5 3 4 6 4 5 7 5 6 1 6 7 2 7 1 3 3

Diagram showing Am chord diagram and a musical staff with notes 3, 5, 3, 5, 6, 5, 6, 8, 8, 10, 12, 10, 12, 12, 12, 12 and fingerings 2, 3, 5, 3, 4, 6, 4, 5, 7, 5, 6, 1, 6, 7, 2, 7, 1, 3, 3.

▶ 范例五 》 推音练习

C



G



C



G



3 5 3 2 3 2 3 0 3 2 0 2 3 1 2 0 3 2 3 0 3 0 2 0 2 1

Diagram showing C and G chord diagrams and a musical staff with notes 3, 5, 3, 2, 3, 2, 3, 0, 3, 2, 0, 2, 3, 1, 2, 0, 3, 2, 3, 0, 3, 0, 2, 0, 2, 1.



# Vincent

"荷兰银行信用卡"电视广告主题曲

Don Mclean













Key **G**

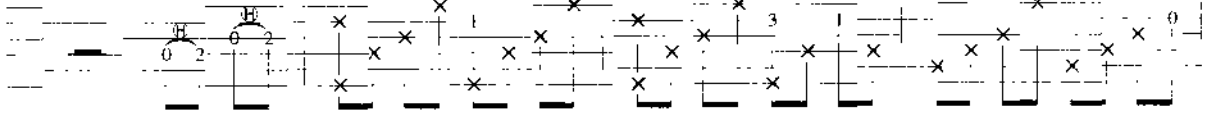

Play **G**

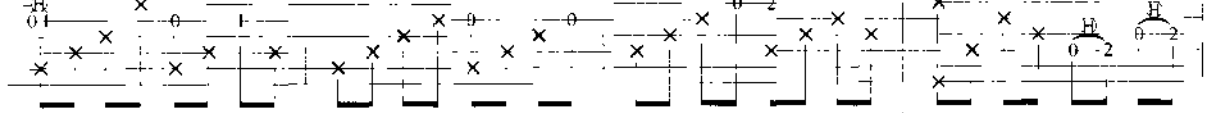

Tempo **4/4**

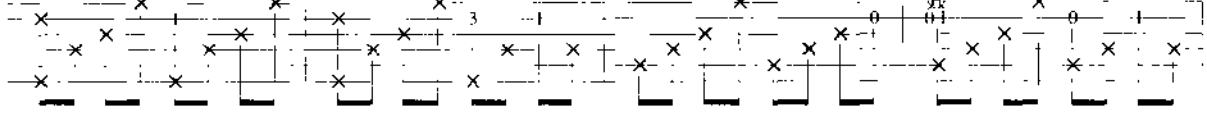
<p><b>G</b></p> 	<p><b>G</b></p> 	<p><b>Am</b></p> 	
			
<p>0 0 5 6 1 2   3 — — —   0 0 3 2 1 6   2 3 6 — —</p>			
<p>Stary stary night paint your pal-ette blue and gray</p>			
<p><b>Am</b></p> 	<p><b>C</b></p> 	<p><b>D7</b></p> 	<p><b>G</b></p> 
			
<p>0 0 3 2 1 6   2 3 6 —   0 7   1 7 6 5 6 7 1 2   3 — 5 6 1 2  </p>			
<p>Look out on a sum-mer's day with eyes that know the darkness in my soul shadows on the</p>			
<p><b>G</b></p> 	<p><b>G</b></p> 	<p><b>Am</b></p> 	<p><b>Am</b></p> 
			
<p>3 — — —   0 0 3 2 1 6 6   2 3 6 — —   0 0 3 2 1 6 6  </p>			
<p>hills sketch the trees and the daf-fo- dils catch the breeze and the</p>			

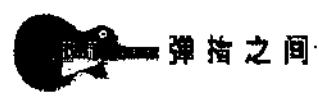

**C** **D7** **G** **G**

2 3 6 — 0 7 1 7 6 5 6 7 1 2 1 — — — 0 0 1 2 3 1

winter chills in colors on the snowy linen land Now I under

**Am** **D7** **G** **G/#F** **Em**

2 — — — 0 0 2 3 4 5 3 3 3 — 0 3 4 3 2 1 6

stand what you tried to say to me How you suffered for you

**Am** **D7** **Em** **A7**

3 2 2 — — 0 2 2 2 3 4 2 3 3 3 4 3 2 1 6 2 3 6 6 —

sanity How you tried to set them free they would not listen they did not know how

**C** **D** **G** **G** **G**

0 0 5 7 1 2 7 | 1 — — — 0 0 5 6 1 2 || 3 — — —



















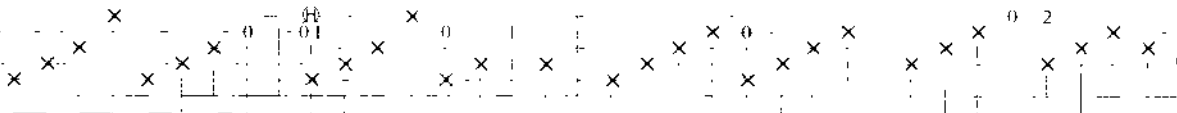

perhaps they'll lis-ten now Stary stary night

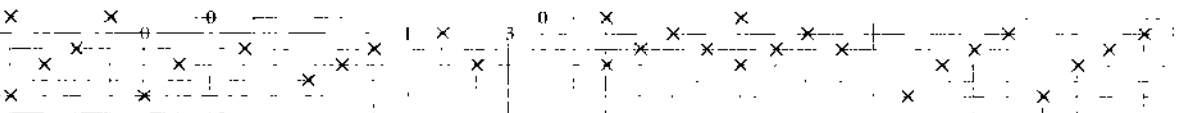
**G** **Am** **Am** **C**

0 0 3 2 1 6 2 3 6 — — 0 0 3 2 1 6 2 3 6 — 0 7

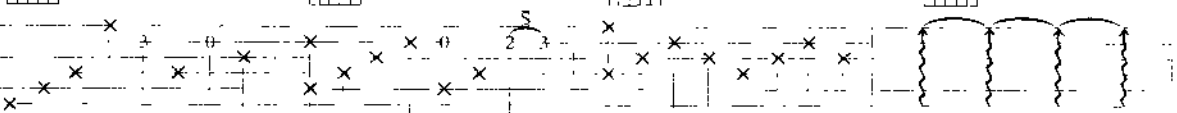
flaming flowers that brightly blaze Swirling cloud in violet haze re-  
 por traits hung in empty halls Fane less heads on name less walls with



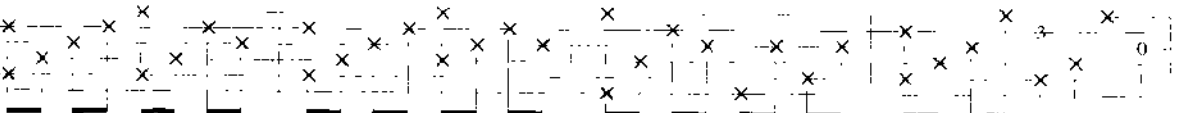

D7 	G 	G 	G 
			
<p>1 7 6 5 6 7 1 2   3 — 5 6 1 2 3 — — —   0 0 3 2 1 6</p>			
<p>flectin vincent's eyes of china blue colors changing hue morning fields of eyes that watch the world and can't for get like the strangers that you've met the ragged man in</p>			
Am 	Am 	C 	D7 
			
<p>2 3 6 — —   0 0 3 2 1 6   2 3 6 — 0 7   1 7 6 5 6 7 1 7</p>			
<p>am ber grain weathered faces lined in pain Are soothed beneath the artist's loving ragged clothes the silver thornof bloody rose Lie crushed and broken on the virgin</p>			
G 	Am 	D7 	G G/#1 
			
<p>1 — 1 2 3 1   2 — — —   0 0 2 3 4 5   3 3 3 —</p>			
<p>hand Now I under stand what you tried to say to me snow Now I think I know what you tried to say to me</p>			
Em 	Am 	D7 	Em 
			
<p>0 3 4 3 2 1 6   3 2 2 — —   0 2 2 2 3 4 2   3 3 3 4 3 2 1 6</p>			
<p>How you suffered for your sanity How you tried to set them free they would not listen they did How you suffered for your sanity How you tried to set them free they would not listen they did</p>			
A? 	C 	D 	G Am 
			
<p>2 3 6 6 —   0 0 5 7 1 2 7   1 — 1 1 2 3   3 2 — —</p>			
<p>not know how perhaps they'll listen now For they could not love you listening still</p>			





  
 0 5 2 2 3 4 | 5 — — — | 0 3 4 5 | 6 5 5 4 4 3 3 4
   
 But still your love was true | And when no hope was left in sight on that

  
 ♩ 6 5 5 4 5 0 6 | 5 4 4 3 3 1 2 3 | 3 — — 0 3 3 | 4 3 3 2 2 3 0 3
   
 stary stary night you took your life as lovers often do | but I could have told you vincent this

  
 4 3 3 2 2 1 7 1 | 0 3 2 1 | 7 1 — — — | 0 0 5 6 1 2 :|
   
 world was never meant for one as beautiful as you | Stary stary

  
 0 0 7 1 2 3 | 5 — — — | 5 — — — | 0 0 0 0
   
 perhaps they never will



  
 0 0 0 0
   
**Fine**



# 26 音乐类型【七】 三指法

利用重根音的演奏方式，在民谣吉他的技巧中，是非常重要的演奏模式。在和弦中，重根音可为主音之三度音或五度音，三指法即利用主根音与三度音或五度音的跳跃交互弹奏法。

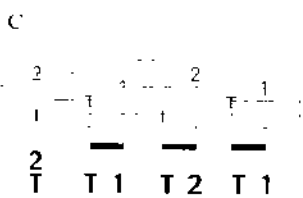
## 以下是几种节奏型态



使用三度音模式

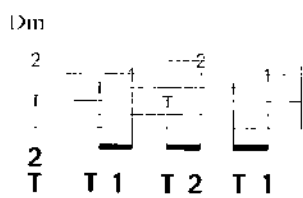

使用五度音模式

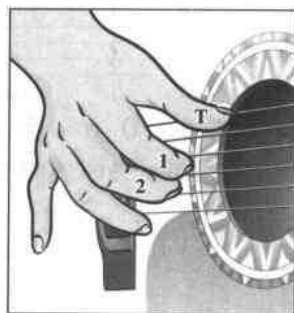

【注】使用第一种型态的弹奏方式弹奏时，如果遇到根音落在第4弦上时，如F、Dm、D，则自动降为第二种型态的弹奏方式（如上图Dm和弦）。在弹奏上，须考虑手的运指方式，重根音的选择往往弹奏在食指上方的根音位置。

## 更多的变化三指法

弹奏 1 个小节和弦时

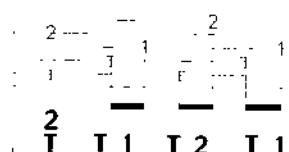
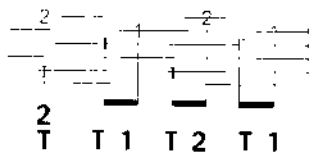
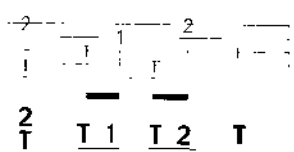

弹奏 2 个小节和弦时

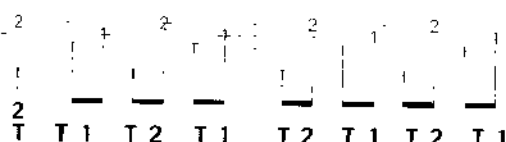
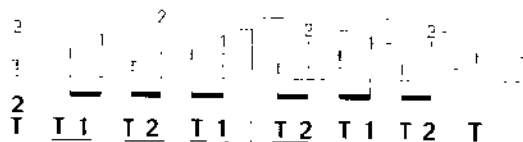



▶ 范例一 《Dust In The Wind》

Chord diagrams and guitar notation for "Dust In The Wind":

- Chord Diagrams:** C, Cmaj7, Cadd9, C, Amadd9, Amsus4, Am, Amadd9, Cadd9, C, Cmaj7, Cadd9, Am, Amadd9, Amsus4, Am.
- Notation:** Six systems of guitar notation showing fret positions and fingerings (1, 2, 3, 7) for each chord.

▶ 范例二 《恋爱症候群》

Chord diagrams and guitar notation for "恋爱症候群":

- Chord Diagrams:** C, G/B, Am, Em, F, C, Dm, G, C, G/B, Am, Em, F, C, Dm, G, C, G.
- Notation:** Three systems of guitar notation including triplets and fingerings (0, 1, 2, 3).



# 还是会寂寞

词/陈绮贞 曲/陈绮贞 演唱/陈绮贞



G

Key



C

Play



6

Capo



4/4, = 76

Tempo



Slow Soul

Rhythm

Cmaj7



3

↑

Fmaj7



5

1

Cmaj7



3

5

Fmaj7



1

3 2 1 7



6 · 2 3 4 | 1 6 6 4 3 3 2 7 7 0 7 5 2 | 1 0 5 3 1 | 1 · 6 6 4 3 1 6 6 2 1 6 | 5 · 5 5 5 5 — ||



5 5 5 5 5 5 5 4 3 2 2 2 2 2 1 3 3 0 1 1 | 1 1 1 1 1 1 7 1 2 2 3 · | 7 5 · 6 7 6 · 6 7 |

早已忘了想 你的滋味是什么 因为每分每秒都被你占据 在心中 你的



1 6 4 4 3 · 2 2 3 4 5 5 5 5 7 6 6 · 1 2 3 6 6 6 1 2 3 6 6 1 2 | 3 5 4 3 2 2 — |

一举一动牵扯在我生活的隙缝 谁能告诉我离开你的我会有多自由



||: 5 5 5 5 5 5 5 4 3 2 2 2 2 2 1 3 3 0 1 1 | 0 1 1 1 1 1 7 1 2 2 3 · | 7 5 · 6 7 6 · 6 7 |

也曾想过躲进别人温暖的怀中 可是这么一来就一点意义也没有 我的



弹指之间



Fmaj7



Em7



Dm7



Dm7/E



Fm



G



3̣ 1̣ | 1̣ 6̣ 1̣ | 1̣ 5̣ 5̣

劝我回心转意

0 2 2 2 | 2 2 3 | 2 5 5

这不是廉价的爱情

0 4 3 | 1 4 3 | 1 1 | 2 1 2

看着我对我说 爱

3 3 4 3 2 | 2 —

我

G



G



Cadd9



G/B



G/B



Am



Am7/G



2/4

2 — — —

2 — — —

5 5 5 | 5 5 5 | 5 4 3 2 | 2 2 2 | 2 2 1 3 | 3 0 1 1

也曾想着躲进着别人 温暖的怀中 可是



0 1 1 | 1 1 1 | 7 1 2 | 2 3 .

这么一来就一点意义

7 5 . 6 7 | 6 . 6 7 | 1 6 4 | 4 3 . 2 2 3 4

也没有 我的高尚情操 一直不断

5 . 5 | 5 7 6 . | 1 2

提醒着我 离开



3 6 6 | 6 1 2 | 3 4 3 2 | 1

你的我不论过多久

1 — — — | 1 1 1 | 1 7 1

还是会 寂

1 — 7 —

寞

喔

Fmaj7



Cmaj7



Fmaj7



Dm7



G



6 — — — | 3 — 3 . 5 | 4 3 2 1 | 1 — — — | 6 . 2 3 4 1 6 6 4 3 3 2 7

答 . . .



7 0 7 5 2 | 1 0 5 7 1

答 . . .

1 . 6 | 6 4 3 1 | 6 6 2 1 6

答 . . .

5 . 5 | 5 5 5 5 | 5 5 7

答 . . .

7 7 1 7

答 . . .

G



G



7 7 . 2 | 2 —

答 . . .

2 2 1 7 1 | 7 1 7 7 1 7 | 7 5 5 —

答 . . .

0 . 1 | 7 5 5 4 5 | 5 . 0 1

答 . . .

7 5 5 4 5 | 5 —

答 . . .

Fade out



弹指之间

# 外面的世界

词/齐秦 曲/齐秦 演唱/齐秦



G

Key



G

Play



4/4

Tempo

G D Em G D Em

0 0 0 0 0 0 0 0 0 0 0 0

C D7 G D/F# Em C D7 G

0 0 0 0 0 0 0 0 0 0 0 0

G D Em C D7 G G

0 3 3 3 5 5 5 4 3 - 0 3 3 2 1 1 - 0 2 2 1 3 3 - - 0

在很久很久以前  
在很久很久以前

你拥有我  
你拥有我

我拥有你  
我拥有你



G D Em C D7 G

在很久很久以前 你离开我去远空翱翔  
 在很久很久以前 你离开我去远空翱翔

C D G C D G

外面的世界很精彩 外面的世界很无奈  
 外面的世界很精彩 外面的世界很无奈

C D G D#m Em Am A D7 D7sus4

当你觉得外面的世界很精彩 我会在这里衷心的祝福你  
 当你觉得外面的世界很无奈 我会在这里耐心的等着你

G D Em C D G

每当夕阳西沉的时候 我总是 在这里盼望你  
 每当夕阳西沉的时候 我总是 在这里盼望你

G D Em C D G

天空中虽然飘着雨 我依然 等待你的归期  
 天空中虽然飘着雨 我依然 等待你的归期





# 27 移调与移调夹 的使用

由于男女先天上之音程分布就不一样，为了迁就歌者的音域，所以在伴奏上也产生了男女调的分别。一般来说，男声部的音程低音通常低到从中央C算起下一个八度的G，高到从中央C算起上一个八度的E之间（即5→3），女声部音程则通常比男生的音域高将近一个八度，从中央E起到高两个八度的C之间（即3→1），当然这也因每个人的声带不同而有所不同。但基本上，如果你不是属于像「张雨生」或「张清芳」型的，那就不会有太大的差异，所以，歌曲的调性，有时则需配合男调或女调来做升高或降低的调整，我们称为移调。移调的方式主要有两种：

## 一、重新写谱移调

1. 决定新的调号。
2. 比较新调与原调两个调性的音程相差几度音程（全音或半音）。
3. 将各和弦依照相差的音程移动成新的和弦。

### C大调转 G大调

原和弦进行 C Am Dm G F Dm G7 C

移调后和弦进行 G Em Am D C Am D7 G

相差3个全音1个半音

### Am调转 Dm调

原和弦进行 Am Dm E7 Am F Dm E7 Am

移调后和弦进行 Dm Gm A7 Dm  $\flat$ B Gm A7 Dm

相差2个全音1个半音



## 二、使用移调夹Capo来移调

譬如说，在一首原调为B调的歌曲中，如果我们要直接弹奏B大调时对于一个初学者而言似乎太残忍了，因为B大调会出现5个变音记号的和弦，如此一来，如果你还不会按封闭和弦，那将难上加难。所以，遇到这种问题时，请先将该调移到你所习惯弹奏的调上，再利用移调夹移到与该调的音程差距（一格为一半音）。

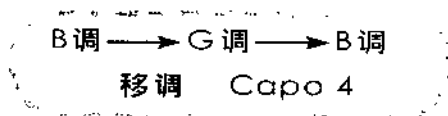

调性 \ Capo Play	0	1	2	3	4	5	6	7
C	C	$\sharp C/bD$	D	$\sharp D/bE$	E	F	$\sharp F/bG$	G
G	G	$\sharp G/bA$	A	$\sharp A/bB$	B	C	$\sharp C/bD$	D

建议大家，第7琴格以后尽量少用Capo，原因是有些和弦把位会不够弹，再者如果你的吉他不是很好，音准可能有所误差。



常见的 Capo



### ※相关技巧的运用：

在一个双吉他的演奏中，常常使用 Capo 来做音程的对应，譬如说 Dm 调，一把吉他可使用开放和弦直接弹奏 Dm 调，另外一把吉他则使用 Capo 夹住第 5 琴格，弹奏 Am 调，一样可以得到 Dm 调的调性，但是味道上可就迷人许多。

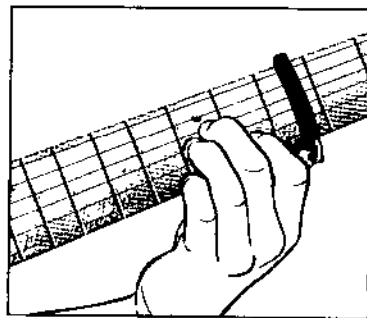
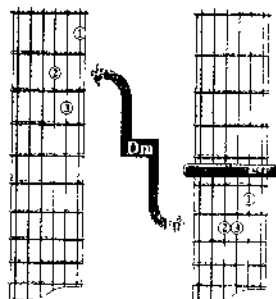

# Guitar 28 封闭和弦

## Barre Chord

在前面的歌曲练习中，想必大家已经把基础的15个开放和弦都练得很熟练了，但是我们当然不会以此为满足。在这一章里，我们将使用这15种开放和弦的指型在指板上移动，所得到的新和弦，我们就通称为封闭和弦（Barre Chords）。

封闭和弦的使用就像是一个随时可移动的移调夹（Capo）。经由开放和弦指型在琴格上任意地移动，而使用食指如移调夹一般紧紧地将弦压制（此时手形需作适度的调整），在指板上分别可以得到12种不同调性的和弦（每移动一个琴格，和弦也随之升高或降低一个半音记号）。换句话说，我们可以找出一组封闭和弦（依照和弦的进行模式），使用这一整组的封闭和弦在指板上作升高或降低，直到找到你所想要的调子。

在练习压弦时，请特别注意左手食指是否完全打直，由其在手指关节处。至于食指可以使用大封闭的压法，或者只封到根音的地方，都可以，但要注意刷弦的位置。

如右图

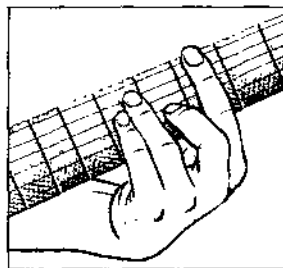

刚开始练习和弦转换时，你可以在前一和弦的第四拍后半拍就提前将手离开弦，利用半拍的空档将下一个和弦压紧，但请注意此时右手的刷法或是指法是保持继续的，别担心手指因提前离开弦而产生的声音，如果只有半拍在弹奏上是允许的。另外也可以使用将手指分解的方法，因为一般和弦在第一拍大多弹在低音居多，所以你可以先压在和弦的根音位置，其他手指再依序加入，掌握练习要诀，练久了，就可以一次就压好和弦了。

【注】在可移动的和弦指型中，如果在移动后使得和弦的根音弹奏起来变得困难，我们习惯使用其第二转位和弦的根音来弹奏，如下图三中的D指型与Dm指型，括弧起来的音就是原本应该弹的音，我们将它移动到下方的第二转位来弹奏。



图一 E指型

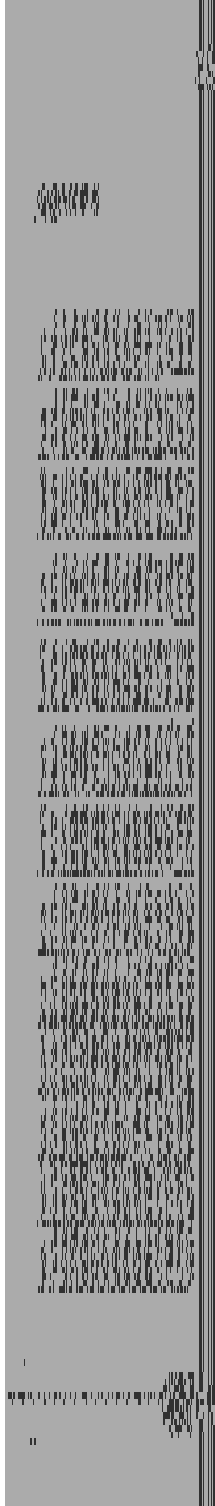

E	Em	E7	Fm7	Emaj7
F	Fm	F7	Fm7	Fmaj7
#F/bG	#Fm/bGm	#F7/bG7	#Fm7/bGm7	#Fmaj7/bGmaj7
G	Gm	G7	Gm7	Gmaj7
#G/bA	#Gm/bAm	#G7/bA7	#Gm7/bAm7	#Gmaj7/bAmaj7
A	Am	A7	Am7	Amaj7
#A/bB	#Am/bBm	#A7/bB7	#Am7/bBm7	#Amaj7/bBmaj7
B	Bm	B7	Bm7	Bmaj7
C	Cm	C7	Cm7	Cmaj7
#C/bD	#Cm/bDm	#C7/bD7	#Cm7/bDm7	#Cmaj7/bDmaj7
D	Dm	D7	Dm7	Dmaj7
#D/bE	#Dm/bEm	#D7/bE7	#Dm7/bEm7	#Dmaj7/bEmaj7
E	Em	E7	Em7	Emaj7



图二 A指型

A	Am	A7	Am7	Amaj7
$\sharp A/bB$	$\sharp Am/bBm$	$\sharp A7/bB7$	$\sharp Am7/bBm7$	$\sharp Amaj7/bGmaj7$
B	Bm	B7	Bm7	Bmaj7
2fr.	2fr.	2fr.	2fr.	2fr.
C	Cm	C7	Cm7	Cmaj7
3fr.	3fr.	3fr.	3fr.	3fr.
$\sharp C/bD$	$\sharp Cm/bDm$	$\sharp C7/bD7$	$\sharp Cm7/bDm7$	$\sharp Cmaj7/bDmaj7$
4fr.	4fr.	4fr.	4fr.	4fr.
D	Dm	D7	Dm7	Dmaj7
5fr.	5fr.	5fr.	5fr.	5fr.
$\sharp D/bE$	$\sharp Dm/bEm$	$\sharp D7/bE7$	$\sharp Dm7/bEm7$	$\sharp Dmaj7/bEmaj7$
6fr.	6fr.	6fr.	6fr.	6fr.
E	Em	E7	Em7	Emaj7
7fr.	7fr.	7fr.	7fr.	7fr.
F	Fm	F7	Fm7	Fmaj7
8fr.	8fr.	8fr.	8fr.	8fr.
$\sharp F/bG$	$\sharp Fm/bGm$	$\sharp F7/bG7$	$\sharp Fm7/bGm7$	$\sharp Fmaj7/bGmaj7$
9fr.	9fr.	9fr.	9fr.	9fr.
G	Gm	G7	Gm7	Gmaj7
10fr.	10fr.	10fr.	10fr.	10fr.
$\sharp G/bA$	$\sharp Gm/bAm$	$\sharp G7/bA7$	$\sharp Gm7/bAm7$	$\sharp Gmaj7/bAmaj7$
11fr.	11fr.	11fr.	11fr.	11fr.
A	Am	A7	Am7	Amaj7
12fr.	12fr.	12fr.	12fr.	12fr.

图三 D 指型

0	D	Dm	D7	Dm7	Dmaj7
1	$\flat D/\sharp C$	$\sharp Dm/\flat E m$	$\sharp D7/\flat E 7$	$\sharp Dm7/\flat E m7$	$\sharp Dmaj7/\flat E maj7$
2	D 2fr.	Em 2fr.	E7 2fr.	Em7 2fr.	Emaj7 2fr.
3	$\sharp D/\flat E$ 3fr.	Fm 3fr.	F7 3fr.	Fm7 3fr.	Fmaj7 3fr.
4	E 4fr.	$\sharp Fm/\flat G m$ 4fr.	$\sharp F7/\flat G 7$ 4fr.	$\sharp Fm7/\flat G m7$ 4fr.	$\sharp Fmaj7/\flat G maj7$ 4fr.
5	F 5fr.	Gm 5fr.	G7 5fr.	Gm7 5fr.	Gmaj7 5fr.
6	$\sharp F/\flat G$ 6fr.	$\sharp Gm/\flat A m$ 6fr.	$\sharp G7/\flat A 7$ 6fr.	$\sharp Gm7/\flat A m7$ 6fr.	$\sharp Gmaj7/\flat A maj7$ 6fr.
7	G 7fr.	Am 7fr.	A7 7fr.	Am7 7fr.	Amaj7 7fr.
8	$\sharp G/\flat A$ 8fr.	$\sharp Am/\flat B m$ 8fr.	$\sharp A7/\flat B 7$ 8fr.	$\sharp Am7/\flat B m7$ 8fr.	$\sharp Amaj7/\flat B maj7$ 8fr.
9	A 9fr.	Bm 9fr.	B7 9fr.	Bm7 9fr.	Bmaj7 9fr.
10	$\sharp A/\flat B$ 10fr.	Cm 10fr.	C7 10fr.	Cm7 10fr.	Cmaj7 10fr.
11	B 11fr.	$\sharp Cm/\flat D m$ 11fr.	$\sharp C7/\flat D 7$ 11fr.	$\sharp Cm7/\flat D m7$ 11fr.	$\sharp Cmaj7/\flat D maj7$ 11fr.
12	C 12fr.	Dm 12fr.	D7 12fr.	Dm7 12fr.	Dmaj7 12fr.



图四 其他指型

0	C	G+	Am7-5	Fdim7	$\flat$ Bdim7	Ddim7
1	$\sharp$ C $\flat$ D	$\sharp$ G/ $\flat$ A $\flat$	$\sharp$ A/ $\flat$ Bm7-5	Fdim7	Bdim7	$\sharp$ D $\flat$ Edim7
2	D 2fr.	A+ 2fr.	Bm7-5 2fr.	$\sharp$ F $\flat$ Gdim7 2fr.	Cdim7 2fr.	Edim7 2fr.
3	$\sharp$ D/ $\flat$ E 3fr.	$\sharp$ A/ $\flat$ B+ 3fr.	Cm7-5 3fr.	Gdim7 3fr.	$\sharp$ C $\flat$ Ddim7 3fr.	Fdim7 3fr.
4	E 4fr.	B- 4fr.	$\sharp$ C/ $\flat$ Dm7-5 4fr.	$\sharp$ G/ $\flat$ Adim7 4fr.	Ddim7 4fr.	$\sharp$ F/ $\flat$ Gdim7 4fr.
5	F 5fr.	C+ 5fr.	Dm7-5 5fr.	Adim7 5fr.	$\sharp$ D/ $\flat$ Edim7 5fr.	Gdim7 5fr.
6	$\sharp$ F/ $\flat$ G 6fr.	$\sharp$ C/ $\flat$ D+ 6fr.	$\sharp$ D/ $\flat$ Em7-5 6fr.	$\sharp$ A/ $\flat$ Bdim7 6fr.	Edim7 6fr.	$\sharp$ G/ $\flat$ Adim7 6fr.
7	G 7fr.	D+ 7fr.	Em7-5 7fr.	Bdim7 7fr.	Fdim7 7fr.	Adim7 7fr.
8	$\sharp$ G/ $\flat$ A 8fr.	$\sharp$ D/ $\flat$ E+ 8fr.	Fm7-5 8fr.	Cdim7 8fr.	$\sharp$ F/ $\flat$ Gdim7 8fr.	$\sharp$ A/ $\flat$ Bdim7 8fr.
9	A 9fr.	E+ 9fr.	$\sharp$ F/ $\flat$ Gm7-5 9fr.	$\sharp$ C/ $\flat$ Ddim7 9fr.	Gdim7 9fr.	Bdim7 9fr.
10	$\sharp$ A/ $\flat$ B 10fr.	$\sharp$ F/ $\flat$ G+ 10fr.	Gm7-5 10fr.	Ddim7 10fr.	$\sharp$ G/ $\flat$ Adim7 10fr.	Cdim7 10fr.
11	B 11fr.	F+ 11fr.	$\sharp$ G/ $\flat$ Am7-5 11fr.	$\sharp$ D $\flat$ Edim7 11fr.	Adim7 11fr.	$\sharp$ C $\flat$ Ddim7 11fr.
12	C 12fr.	G+ 12fr.	Am7-5 12fr.	Edim7 12fr.	$\sharp$ A/ $\flat$ Bdim7 12fr.	Ddim7 12fr.





Em Bm Em Bm Am7 D Em Bm

6 6 6 5 5 5 5 5 5 3 6 6 6 5 5 5 3 2 1 2 3 5 3 2 0 3 5 | 6 6 6 5 5 5 5 5 5 3

试着将它慢慢溶化 看我 在你心中 是否 仍完美无瑕 是否 依然为我丝丝牵挂  
真爱总是可以长久 为何你的眼神 还有 孤独时的落寞 是否 我只是你一种寄托

Em Bm Em Bm Am7 D G Bm

6 6 6 5 5 5 5 5 5 3 6 6 6 5 5 5 3 2 1 2 3 3 5 3 2 2 0 3 2 | 1 1 1 6 2 2 3 0 3 2

依然爱我无法自拔 心中是否还有未曾 到过的地方啊 那里 湖面总是澄清 那里  
填满你感情的缺口 心中那片森林 何时 能让我停留

G Bm C Em C D

1 1 1 6 2 2 3 0 3 5 6 5 5 3 6 5 6 0 3 5 6 5 5 5 3 6 5 5 5 | 2 0 0 3 5 :

空气充满宁静 雪白 明月照在大地 藏着 你不愿提起的回忆 你说

C D Em Bm Am Em

6 5 5 5 3 6 5 5 5 2/4 0 1 1 6 6 3 2 3 3 1 3 2 2 2 2 1 6 1 1 6 6 6 1

你最深处的秘密 或许我 不该问 让你 平静的心再起涟漪 只是

C D C D Em Bm Am Em

1 1 1 1 1 1 6 1 2 2 3 5 6 5 5 5 3 6 6 5 1 1 6 6 3 3 2 3 3 1 3 | 2 2 2 2 1 6 1 1 6 6 6

爱你的心超出了界限我想拥有你所有一切应该是 我不该问 不该 让你再将往事重提

C D G

1 1 1 1 1 6 6 6 5 5 3 2 6 6 1 1 - - -

只是心中枷锁该如何才能解脱 ※

C D D

6 5 5 5 3 6 5 5 5 2/4 0 0 0 0 0 0 0 0 | 0 0 0 0 |

你最深处的秘密 (Drums Fill)

Em Bm Am Em C D

0 0 0 1 1 6 6 3 2 3 3 1 3 | 2 2 2 2 1 6 1 1 6 6 6 1 | 1 1 1 1 1 6 1 2 2 3 5

或许我 不该问 让你 平静的心再起涟漪 只是爱你的心超出了界限我想





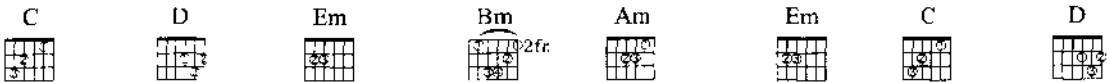

  
 6 5 5 3 6 6 5 1 1 6 | 6 . 3 3 2 3 3 | 1 3 | 2 2 2 2 1 6 1 1 6 6 | 1 1 1 1 1 6 6 6 5 5 3 2 6 |
   
 拥有你所有 一切应该是 我不该问 不该 让你再将往事重 提 只是心中枷锁该如何才能解

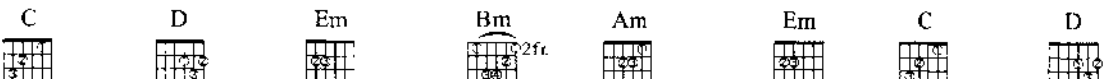
  
 6 1 1 - 1 1 6 | 6 3 2 3 3 | 1 3 | 2 2 2 2 1 6 1 1 6 6 6 1 | 1 1 1 1 1 1 6 1 2 2 3 5 |
   
 脱 或许我 不该问 让你 平静的心再起涟漪 只是爱你的心超出了界限我想

  
 6 5 5 3 6 6 5 1 1 6 | 6 . 3 3 2 3 3 | 1 3 | 2 2 2 2 1 6 1 1 6 6 | 1 1 1 1 1 6 6 6 5 5 3 2 6 |
   
 拥有你所有 一切应该是 我不该问 不该 让你再将往事重 提 只是心中枷锁该如何才能解

  
 6 1 1 0 1 1 7 :|
   
 脱 啊啊啊
   
 Repeat Intro Fine



# 征服

词/袁惟仁 曲/袁惟仁 演唱/那英

Key: E - E Play: C - C Capo: 3 Tempo: 4/4 = 67

Fingers | TT12 2321 TT12 2321 |

Picking | X ↑↑↑↑↑↑↑↑↑↑ |

Am F/C G F F B/C Dm7

0 6 1 7 5 6 3 4 3 1 1 0 3 1 2 5 4 1 6 2 1

Piano Strings

1 - - - 3 4 5 1 1 6 7 1 1 7 6 5 -

C Am7 F

0 5 5 1 1 2 2 1 2 3 5 3 5 5 6 6 0 0 3 3 4 3 2 2 1 1 6 6 6 1

终于你找到一个方式分出了胜负 输赢的代价是彼此粉身  
终于我明白俩人要的是一个结束 所有 的辩解 都让对方以为 是

Gsus4 C C/E Am7

3 2 2 - 0 0 5 5 1 1 2 2 3 3 5 5 5 6 1 1 0 0 3 3

碎骨 外表健康的你心里伤痕无数 顽强  
企图 放一把火烧掉你送我的礼物 却浇

F F/G C G C

4 3 2 1 6 3 5 0 1 1 2 1 1 - 0 5 1 7 5 5 6 5 5 0 5 1 7 5

的我是这场战役的俘虏 就这样被你征服 切断了所  
不熄我胸口灼热的愤怒

Am F G

6 3 6 6 0 6 6 6 5 3 3 4 4 0 4 4 4 5 6 3 4 1 2 5 1 7 5



有退路 我的心情是 坚固 我的决定是 糊 涂 就这样被

C Am F G



5 6 5 5 0 5 1 7 5 6 3 6 6 0 6 6 6 5 3 3 4 4 0 4 4 4 3 1



你征服 喝下你藏好的毒 我的剧情已 落幕 我的爱恨已



 C      Am      F      G      C  
 2 · 1 1 - - | 7 · 1 6 6 4 3 4 5 | 1 5 1 1 5 3 3 0 6 1 6  
 入 土 **E.G. Solo**

 A       B $\flat$       F      G      Am  
 3 3 2 1 1 · 6 6 1 1 6 6 6 5 5 5 6 1 2 3 3 2 1 5 5 4 5 4 3 1 7 1 7

 G/D      G  
 7 5 4 3 5 5 0 5 1 2 | 3 4 5 1 7 1 3 4 5 6 6 5 5 4 · 3 2 · 1 :||

 C       B $\flat$       Am  
 2 · 1 1 - - | 0 4 4 4 4 · 3 4 5 4 4 1 4 3 3 2 3 3 0 |  
 入 土 你如果经 过我 的 坟 墓

 B $\flat$       C       #G<sup>4fr.</sup>  
 0 4 4 4 4 · 3 5 4 1 4 | 5 · 6 5 0 |  $\frac{2}{4}$  0 · 5 1 7 5 |  
 你可以双 手合十 为我 祝 福 (转 #C Key) 就 这样被

 #C<sup>4fr.</sup>       #Am      #F chord diagram" data-bbox="625 610 665 640"/> #F<sup>2fr.</sup>  
 5 6 5 5 0 · 5 1 7 5 | 6 3 6 6 0 6 6 6 5 3 3 4 4 0 4 4 4 5 6  
 你征服 切 断了所 有退路 我的 心情是 坚固 我的 决定是

 #G<sup>4fr.</sup>      #C chord diagram" data-bbox="375 700 415 730"/> #C<sup>4fr.</sup>      #Am chord diagram" data-bbox="625 700 665 730"/> #Am  
 3 · · 4 1 2 5 1 7 5 | 5 6 5 5 0 · 5 1 7 5 | 6 3 6 6 0 6 6 6 5 3  
 糊 涂 就 这样被 你征服 喝 下你藏 好的毒 我的 剧情已

#F chord diagram" data-bbox="125 795 165 825"/> #F<sup>2fr.</sup>      #G chord diagram" data-bbox="245 795 285 825"/> #G<sup>4fr.</sup>      #C chord diagram" data-bbox="375 795 415 825"/> #C<sup>4fr.</sup>  
 3 4 4 0 4 4 4 3 1 | 2 · 1 1 0 · 5 1 7 5 |  
 落 幕 我的 爱恨已 入 土 就 这样被 **Fade Out**











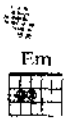

















## 温柔

词/阿信 曲/阿信 演唱/五月天

电视剧“侠女闯天关”片尾曲

● - Key G ● - Play G ● - Tempo 4/4, =74 ● - Rhythm Slow Soul ● Picking | X ↑↑↑ ↓↑↑ ↑↑↑ ↓↓ - -

G 	Em 	C 	D 
1 2 3 6 5 5 -	1 2 3 7 5 5	1 2 3 6 5 -	1 2 3 7 5 5
G 	Em 	C 	D 
3 2 3 2 3 2 3 2	3 2 1 6 1 1 -	4 3 4 3 4 3 4 3	4 5 2 1 2 2 -
走在 风中 今天 阳光	突然 好温柔	天的 温柔 地的 温柔	像你 抱着我
Bm7 	Em 	Am7 	D 
5 4 5 4 5 4 5 4	5 6 3 2 3 3 3 1	6 7 1 2 3	1 2 3 7 5 5 -
然后 发现 你的 改变	孤单 的今后 如果	冷 该怎 么 渡	过 - - -
G 	G 	Em 	C 
0 1 7 1 5 -	3 2 3 2 3 2 3 2 2	3 2 1 6 1 1 -	4 3 4 3 4 3 4 3 3
	天边 风光 身边 的我都	不在 你眼中	你的 眼中藏着 什么我
D 	Bm7 	Em 	Am7 
4 5 2 1 2 2 -	5 4 5 4 5 4 5 4	5 6 3 2 3 3 3 1	6 7 1 2 3
从来 都不懂	没有 关系 你的 世界	就 让你 拥有 不 打	扰 是 我 的 温
G 	G 	G 	Em 
1 2 3 7 5 5	0 1 7 1 5 -	5 3 3 3 2 2 2 1 2 3	0 6 6 3 5 5 3
1 - - -	0 0 0 0 5 5	道 不 明 了 不 想 要 为 什 么	我 的 心 明
柔	不 知		
C 	D 	G 	Em 
6 7 6 5 3 3 3	6 7 6 5 2 2 5 5	5 3 3 3 2 2 2 1 2 3	0 6 6 3 5 5 3
明 是 想 靠 近 却	孤 单 的 黎 明 不 知	道 不 明 了 不 想 要 为 什 么	我 的 心 那





6 7 6 5 3 3 · 3  
爱情的绮丽



3 2 3 2 3 2 3 2 2  
不知不觉 不情不愿又



5 4 5 4 5 4 5 4 4  
没有 预兆没有 理由你



7 7 1 1 —



7 7 1 1 —



— — — 3  
自



1 · 7 7 7 1 2  
柔 这是我的温



5 3 2 1 — — —  
呜...



3 — — — 3 — — —



3 — — — 3 — — —



6 7 6 5 2 2 · 3 3  
总 是在孤单里 再把



3 2 1 6 1 1 —  
走到 巷子口



5 6 3 2 3 3 3 1  
真的 有说过 如果



3 3 3 3 —



3 3 3 3 —



1 — — — 2 · 7 7 7 1 2  
这是 我的温



1 · 7 7 7 · 1 — — — 2  
柔 这是我的 温



7 7 2 3 | 3 — — —  
让 你 自



0 7 5 6 4 5 4 3 — — —



3 — — — 3 — — —



4 3 4 3 4 3 6 5  
我的 最好 的爱 给



4 3 4 3 4 3 4 3  
我 没有 哭 也 没有 笑



6 7 1 2 3  
有 就 让 你 自



6 6 7 7 —



6 6 7 7 · 5 5



— — — 1 — — —  
不 知 由



1 · 7 7 7 1 2 | 1 — 3 6 |  
这是 我的 温 柔 这是我的 温 柔 呜...



7 7 2 3 | 3 — — —  
让 你 自



0 7 5 6 4 5 4 3 — — —



3 — — — 3 — — —



5 — — — ||  
你 (嘿)



4 5 2 1 2 2 — |  
因 为 这 是 梦



2 2 2 2 — |  
1 2 2 2 — |



2 2 2 2 — |



— 2 — —



1 — — — 1 — — —



1 — 3 6 |



3 — — —



3 — — —



3 — — —

Fine



# 你要的爱

电视剧“流星花园”片尾曲/电影“浓情巧克力”中文主题曲

词/戴佩妮 曲/戴佩妮 演唱/戴佩妮



F

Key



F

Play



4/4 ♩ = 74

Tempo



Slow Soul

Rhythm

F      A      Dm7      Cm7

0 0 3 5 5 3    7 2 7 7 —    0 0 6 5 6 5 3 2 1 | 1 3 3 1 2

虽然经常    梦见你                    还是毫无头绪                    外面

B      A7      Dm      G7      C

3 3 3 6 6 6    7 1 ·    7 5 2 3 3 · 5 5 3 2 | 1 1 3 5 6 6 2 | 2 — — —

正在下着雨    今天    是星期几    But I don't know    你去那里

F      A      Dm7      Cm7      F

0 0 3 5 5 3    7 2 7 7 —    0 0 6 5 6 1 2 1 | 1 3 3 — 2 1 |

虽然不曾    怀疑你                    还是忐忑不定                    哦——

1 2 2 6 7 1 1 2 7 5 3 3 1 1 3 5 6 6 5 5 5 6 1 3 3 5 5 5 5 5 3
   
 谁是你的那个惟一 原谅我 怀疑自己 我明白

3 2 1 1 3 2 1 3 7 — 3 2 1 2 1 1 1 2 2 0 6 1 | b3 2 2 2 6 1 | b3 2 2 1
   
 我要的爱 会把我宠坏 像一个小孩 只懂在你怀里

3 5 3 3 3 2 1 3 7 — 3 2 1 2 1 1 1 2 2 0 6 6 1 | b3 2 2 2 6 1 | b3 2 2 2 6 1 |
   
 坏 你要的爱 不只是依靠 要像个 大男孩 风吹日晒 生活

b3 2 2 1 1 b6 b6 5 5 — — 5 6 1 7 b6 3 2 2 3 3 2 1 | 2 3 2 1 2 6 1 2 1 3 2 1
   
 自由自在 唉 (Organ)

3 — 5 3 1 2 6 :| b3 2 2 2 6 1 | b3 2 2 2 6 1 | b3 2 2 1 1 5 4 3 4 | 3 — — 2 1 7
   
 大男孩 风吹日晒 生活 自由自在 (Organ)



A Dm G7 Gm C F

7 — — 3 | 3 — 3 3 2 1 | 4 — 4 . 5 0 6 — 6 7 1 2

A Dm Gm B

b6 . 6 6 6 1 2 3 2 2 1 | 6 6 6 1 b3 2 2 1 5 5 5 3

我明白

F A B G

0 — — 1 7 | 0 1 1 — — 0 0 0 0 | 0 3 2 2 1 1

唉唉 唉 (Organ)

F A B G

1 — — 1 2 3 — 3 7 7 | 1 — — — b5 — — —

F

5 — — — 5 — — —

Fine



# 29 出神入化的PICK Guitar 弹奏

在前面章节的音乐形态练习中，相信大家已经学会了拿PICK的要领，但是在歌曲的弹唱中，相信你还会有些疑问？在歌曲中如果主歌(A段)部份使用手指弹指法，副歌(B段)要使用PICK弹节奏，要如何转换？

没错！由于PICK在吉他的弹唱中，使用起来非常的方便，所以大家都比较喜欢使用PICK来弹奏，针对这一点，我想已经有许多的朋友开始学会使用PICK来弹指法的技术，这种技巧在电吉他上更是必学的技巧之一。用PICK来弹奏，可以让曲子，时而抒情、时而奔放、时而轻松、时而狂野。

下面的练习中，请大家多注意PICK的下压(▣)及上勾(∨)，当然你可以依自己的习惯来弹奏，但请注意手腕上下摆动的协调性。

## ▶ 范例一

C Am F G C

## ▶ 范例二

G Em C D G



## ▶ 范例三

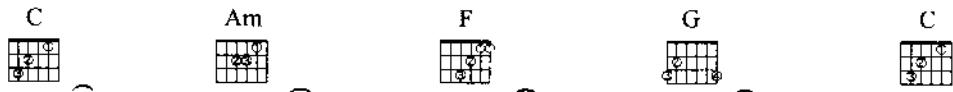

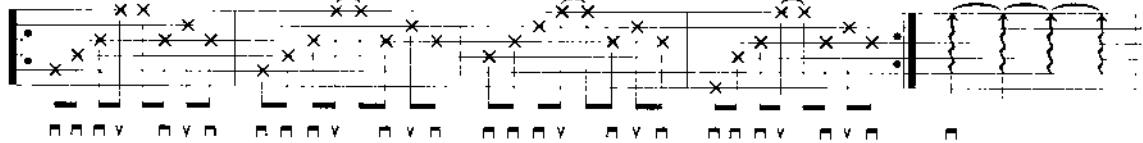

C Am F G C

## ▶ 范例四

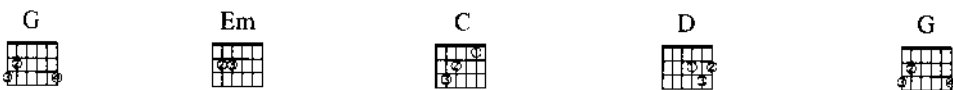

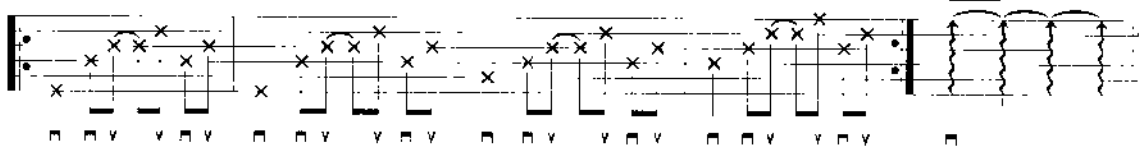

G Em C D G



# 30 大调音阶与 小调音阶

## 一、大调音阶与小调音阶

大调音阶与小调音阶的主要差别，在于音与音之间的音程排列。如果一个音阶由起始音向上，以“全音、全音、半音、全音、全音、全音、半音”，的规则递升，则我们称它为「大调音阶」。而自然小调音阶则是以“全音、半音、全音、全音、半音、全音、全音”，的规则递升（如下图）。另外，如果一个音阶中的第1音至第3音，像大调音阶一样，相差2个全音（大三度），则这个音阶被归类于大调音阶系；反之如果音阶中的第1音与第3音，像自然小调一样相差一个全音一个半音（小三度），则被归类于小调音阶系。

C大调音阶

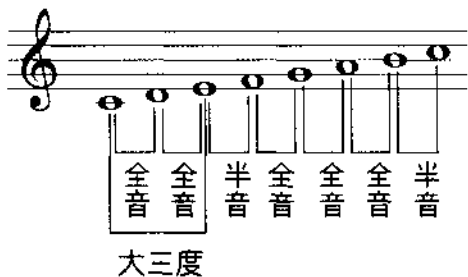

C小调音阶

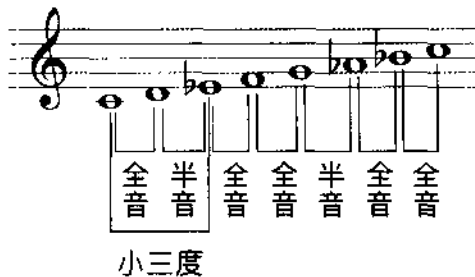

## 二、关系大小调

在音阶中，如果一个大调音阶与一个小调音阶的组成份子完全相同，只有起始音不同，我们就称它们互为「关系大小调」。在下图中，我们称 Am 调为 C 调的关系小调，每个小调均有它的关系大调，所以它们之间可以共用一群音阶，但须注意它们的起始音是不同的。

C大调音阶

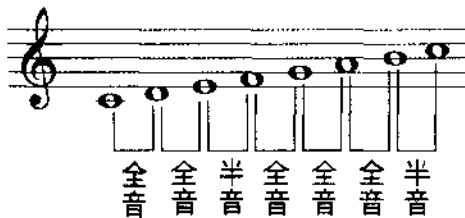

A小调音阶

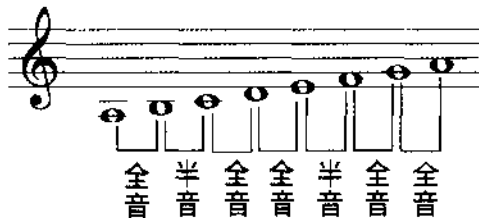

### 快速判别关系大小调的方法:

将任意一个大调往上推六级的小调即为关系小调。将任意一个小调往上推三级的大调即为关系大调。

### 三、音阶指型

为了方便我们记忆音阶的位置，我们将一整个吉他琴格分成数个音阶指型，这些指型习惯上以第一个起始的音来命名。

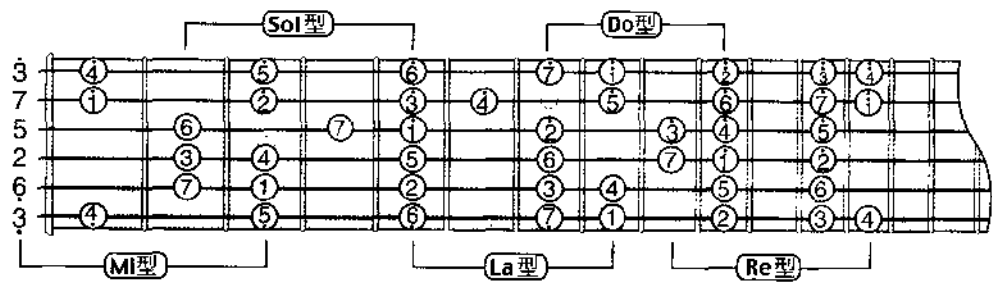

C大调Mi型音阶(Am调)

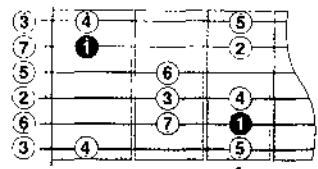

C大调 Sol 型音阶(Am调)

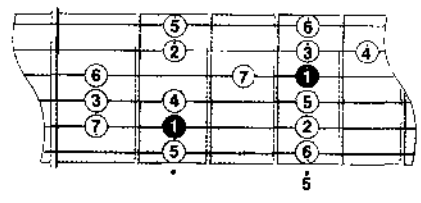

C大调La型音阶(Am调)

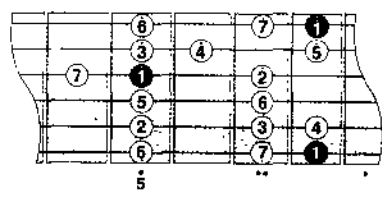

C大调Do型音阶(Am调)

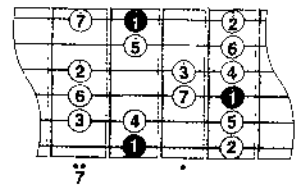

C大调Re型音阶(Am调)

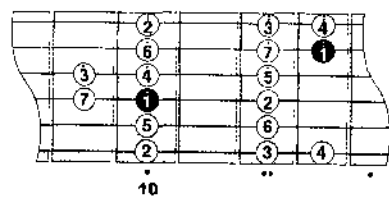

利用以上这些指型在指板上做移动，便可得到其他不同调之音阶。



### 四、联结两个指型的音阶

So型→La型

La型→Do型

Do型→Re型

### 五、五声音阶的联结

#### A小调五声音阶

依序唱名：6 → 1 → 2 → 3 → 5 → 6 → 1 → 2 → 3 → 5 → 6 → 1 → 2 → 3

#### E小调五声音阶

依序唱名：6 → 1 → 2 → 3 → 5 → 6 → 1 → 2 → 3 → 5 → 6 → 1 → 2 → 3 → 5 → 6



## 六、大调音阶的联结

### C 大调音阶

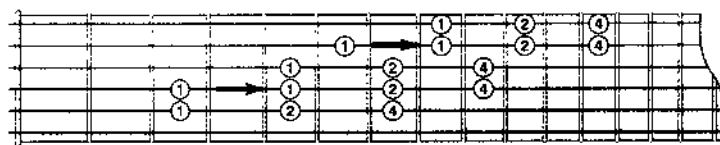

依序唱名：1 → 2 → 3 → 4 → 5 → 6 → 7 → 1̇ → 2̇ → 3̇ → 4̇ → 5̇ → 6̇ → 7̇ → 1̇̇ → 2̇̇ → 3̇̇

### G 大调五声音阶

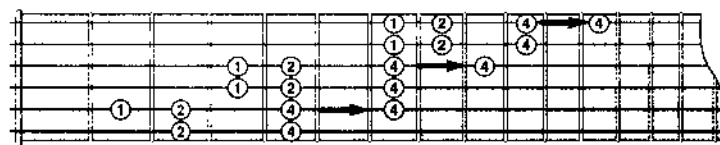

依序唱名：1 → 2 → 3 → 4 → 5 → 6 → 7 → 1 → 2 → 3 → 4 → 5 → 6 → 7 → 1̇ → 2̇ → 3̇

上图中① ② ③ ④ 分别代表左手食指、中指、无名指、小指。

【注】记忆音阶，不同于古典乐使用的“固定调”唱法（固定C调的方式）唱名随调行不同而改变，在流行音乐中则采用“首调”式的唱法，也就是唱名不会因调性不同而改变。请比较范例中C调与G调之唱名，在首调唱法中都是一样的。

# 自由

词/张震岳 曲/张震岳 演唱/张震岳



1 1: 16 1 16 1 1: 16 1 16 1 1: 16 1 16 1 1: 16 1 16



1 1: 1 6 1 16 1 1: 16 1 16 1 1: 16 1 16 1 1: 16 1 16



0 3 3 3 3 3 2 2 0 0 3 2 1 6 1 1 6 3 3 3 2 2 0 0

也许会恨你 我知道 我的脾气不是很好  
我没有关系 你可以 假装没事离开这里



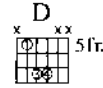

0 3 3 3 3 3 2 2 0 0 3 2 1 | 6 1 1 6 3 3 3 2 2 0 0

也许不 一 定 我 知 道 我 还 是 一 样 爱 着 你  
 一 切 好 安 静 我 只 是 想 把 情 绪 好 好 压 抑

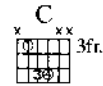
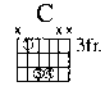

0 3 3 3 3 3 4 4 3 3 2 2 1 1 | 0 3 3 3 5 5 4 4 3 3 2 2 1 1

打 开 一 瓶 红 色 的 酒 看 着 金 鱼 游 来 游 去  
 到 底 谁 会 先 说 的 再 见 我 知 道 我 一 定 哭 泣

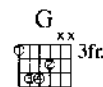
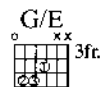
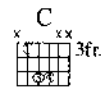

0 2 2 2 2 2 4 4 3 3 2 2 1 2 1 | 1 1 1 6 1 1 6 1 1 6 1 1 6

是 否 我 们 都 想 要 自 由  
 走 的 时 候 记 得 说 爱 我

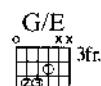
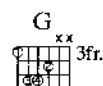
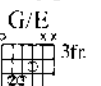
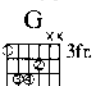
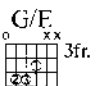

1 1 1 6 1 1 6 1 1 6 1 1 6 :| 1 1 1 6 1 1 6 1 1 6 1 1 6

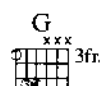
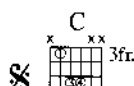
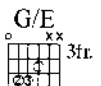





1 1 1 6 1 1 6 1 0 3 5 5 1 1 4 4 6 6 5 5 3 5 5 1

说 爱 我 说 爱 我 难 道 你







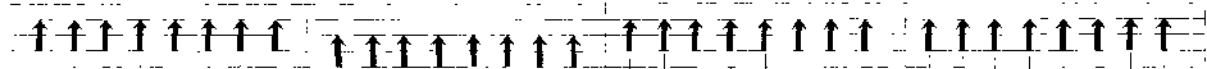

 3fr.     
  3fr.     
  7fr.     
  2fr.







1 1 4 6 6 5 5 — 3 2 1 1 — 1 1 7 7 6 5 3 5 5 6  
 不 再 爱 我 我 的 泪 滴 下 来 你 从 来

 3fr.     
  5fr.     
  3fr.     
  3fr.





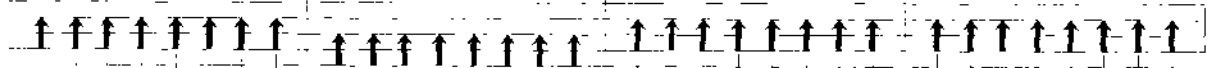

6 1 1 1 1 3 2 2 2 — 3 5 5 1 1 — 4 6 6 5 5 — 3 5 1  
 不 曾 看 过 为 什 么 为 什 么 爱 情 让

 3fr.     
  3fr.     
  7fr.     
  2fr.





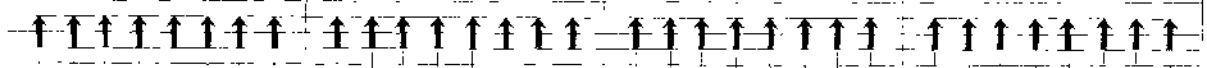

1 1 1 4 4 6 6 5 5 — 3 2 1 1 — 1 1 7 7 6 5 3 5 5 6  
 我 变 沉 重 没 有 人 告 诉 我 原 来 不

 3fr.     
  5fr.     
  7fr.     
  6fr.



6 1 1 1 1 3 3 2 2 — 0 1 1 3 — 0 3 4 3 3 — 0 4 4 3  
 是 我 想 像 不 要 回 来 你 已

 4fr.     
  4fr.     
  3fr.     
  5fr.

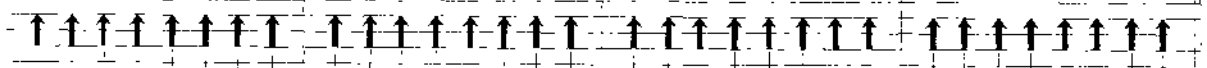



3 3 3 3 3 2 1 2 1 1 — 0 0 0 0 0 1 1 3 3 3 3 3 2 1 1  
 经 自 由 了 我 也 已 经 自 由 了

D.C.N/R

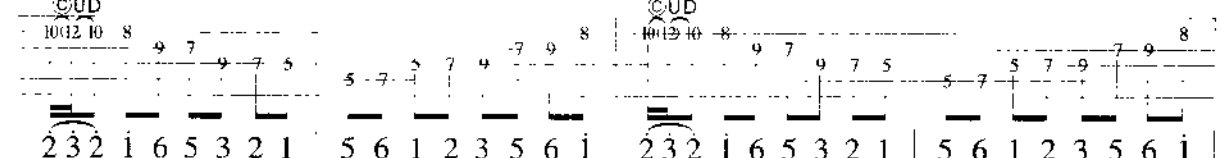

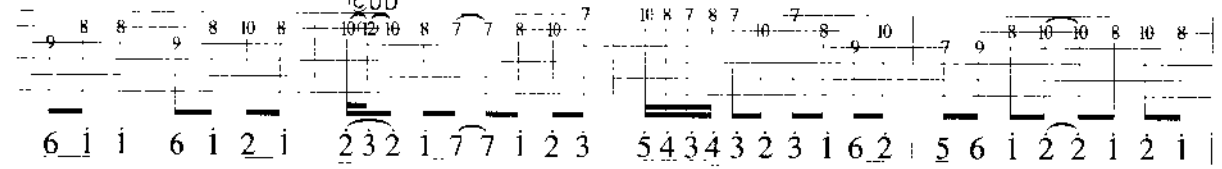

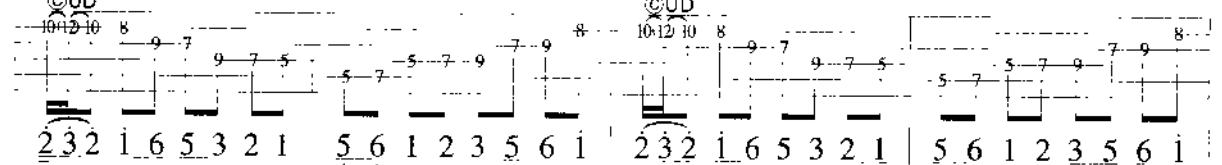

  
**(GT. Solo)**

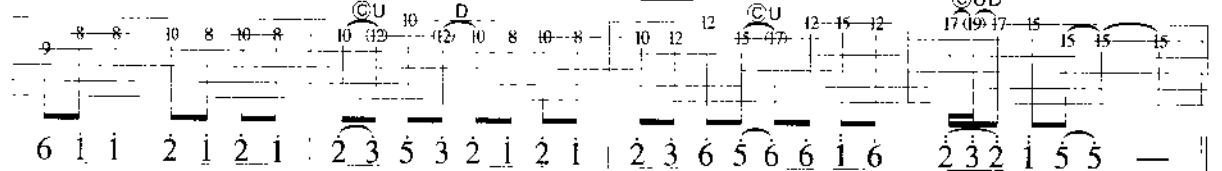
说爱 我

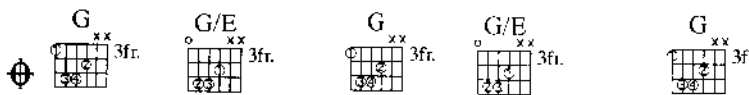
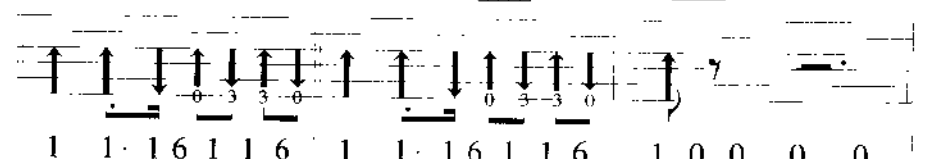

  
**Fine**



# 志明与春娇

词/阿信 曲/阿信 演唱/五月天



E



E



4/4, = 78



Slow Soul

E #Gm7 #Fm7 A B

0 1 7 1 2 3 4 5 5 — — — | 0 1 7 1 2 3 4 5 6 7 1 3 5 4

(strings)

E #Gm7 #Fm7 A B

4 5 4 5 7 4 5 7 | 0 4 0 2 4 5 7 3 5 5 4 2

3 1 7 1 2 3 4 5 5 — — — | 0 1 7 1 2 3 4 5 5 3 1 6 5 4

E #Gm7 #Fm7 A A/B

3 0 3 2 3 3 2 2 1 | 2 5 5 — 2 3 3 3 1 1 — 6 1 3 3 2 1 2 1 1 5 6

志明真正不知要安怎为什么 爱人 不愿搁再相 佞  
志明心情真正有影寒 风这大 你也 真正拢没心 肝



E 4fr. #Gm7 4fr. #Fm 4fr. A 5fr. A/B 5fr.

5 0 3 3 3 3 2 2 1 2 5 5 5 0 2 3 1 1 — 0 · 6 1 | 3 3 2 1 2 1 1 0 1 2

春娇已经早就无在听讲这多其实拢总拢无卡抓啊...  
春娇你那无要和我播这出电影咱就走这位准抵煞啊...

E Guitar 1 similar #Gm7 4fr. #Fm7 2fr. A B 2fr.

1 · 5 5 5 1 1 7 5 5 : 5 — — 0 3 5 6 5 6 6 1 · 1 — | 3 3 2 1 1 3 3 2 2 1 2 · 1

走到淡水的海岸两个人的爱情已经无人看已经无人听啊...

E #Gm7 4fr. #Fm7 2fr. A B 2fr.

1 5 5 5 · 5 5 5 3 4 5 5 5 5 · 5 5 5 3 4 5 4 5 4 · 6 6 0 6 · | 6 2 1 · 5 5 6 5

我跟你最好就到这你对我已经没感觉到这冻止你也免爱我

E #Gm7 4fr. #Fm7 2fr. A B 2fr.

0 5 5 5 · 5 5 5 3 4 5 5 5 5 · 5 5 5 3 4 5 4 5 4 · 6 6 6 1 | 3 2 2 1 5 5 2 1

我跟你最好就到这你对我已经没感觉麦搁伤心麦搁我这爱你你没爱

E — 1. — #Gm7 4fr. #Fm7 2fr. A B 2fr.

X 5 4 5 7 4 5 7 0 4 0 2 4 5 7 3 5 5 4 2

1 1 7 1 2 3 4 5 5 — — — | 0 1 7 1 2 3 4 5 5 3 1 6 5 4 :

我





E 4Gm7 4fr. #Fm7 A B

5 4 5 2 4 5 7 | 5 — — — | 0 4 0 2 4 5 7 | 3 5 5 4 2

5 1 7 1 2 3 4 5 | 5 — — — | 0 1 7 1 2 3 4 5 | 5 3 1 6 5 4

E<sup>maj7</sup> 7fr. E<sup>maj7</sup> 7fr.

3 — — — — — | 3 — — — — — |

Fine

# Guitar 31 双音

## 一、双音

让两个以上各自独立的旋律，组合起来而同时进行的作曲方式，我们称之为对位法。双音即是最简单的一种对位法的应用。

## 二、定旋律与对旋律

在弹奏双音之前，首先必须决定一种旋律进行，作为组合其他旋律的基础，这样的方式，我们称为定旋律。依照定旋律所相对组合出来的旋律，就称为对旋律（双音）。

## 三、依照定旋律与对旋律之间的音程差

我们把常用的双音弹奏分为下列几种，大、小二度；大、小三度；完全四度；完全五度；小六度；完全八度；十度。

平行三度

定旋律	6	7	1	2	3	4	5	6	7	1	2	3	4	5	6	7
对旋律	4	5	6	7	1	2	3	4	5	6	7	1	2	3	4	5

完全四度

定旋律	1	2	3	4	5	6	7	1	2	3	4	5	6	7	1	2
对旋律	5	6	7	1	2	3	4	5	6	7	1	2	3	4	5	6



完全八度

	3	5	7	4	5	7	5	6	6	5	7	8	10	12	
	1	3	5	2	3	5	2	3	5	2	4	5	7	9	
{ 定旋律 对旋律	4	5	6	7	1	2	3	4	5	6	7	1	2	3	0 0
	4	5	6	7	1	2	3	4	5	6	7	1	2	3	0 0

平行十度

	0	2	0	1	3	0	1	3	5	7	8	10			
	0	3	0	2	3	0	2	3	5	7	9				
{ 定旋律 对旋律	5	6	7	1	2	3	4	5	6	7	1	2	0	0	0 0
	3	4	5	6	7	1	2	3	4	5	6	7	0	0	0 0





# To Be With You

Mr. Big



Key



Play



Tempo

4/4 = 88

#Cm



4fr.

E



Aadd9



E



#Cm



4fr.

E



0 0 0 0 | 0 3 3 3 2 1 3 2 3 3 | 2 1 2 2 3 2 2 1 1 1 | 0 6 3 3 2 1 3 2 3 3

Hold on little girl Show me what he's done to you stand up little girl  
Build you confidence So you can be on top for once wake up who cares about

Aadd9



E



Aadd9



E



Aadd9



E



D



2 1 2 2 3 2 2 1 1 1 3 | 2 2 1 1 3 2 1 1 | 2 1 1 1 2 3 3 1 1 6 5 | 4 3 3 2 2 4 3 3 2 2

broken heart can't be that bad when It's through hit's through Fate will twist the both of you so come on baby come on over  
little boy that talk too much I seen It all go down you game of love was all rained out so come on baby come on over

B



2fr.

E



Aadd9



B



2fr.

E



E



Aadd9



4 3 3 2 2 5 5 3 2 2 1 | 3 4 5 1 6 5 | 2 3 3 — — | 3 4 5 1 6 3 |

Let me be the one to show you I'm the one who wants to be with you Deep in side I hope you  
Let me be the one to hold you



B E E Aadd9 B #Cm E Aadd9

2 1 1 1 — 3 4 5 1 6 5 2 3 3 — — 3 4 5 1 6 3

feel it too wait-ed on a line of greens and blues Just to be the next to

B E Aadd9 #Cm G

2 1 1 1 — :| 0 0 3 2 1 1 6 0 5 1 2 3 2 2 2 1 2 2 3 3 4 b3 b3 b3 2 2 2 1 b7

be with you Why be a-lone when we can be together baby You can make my life worth while

G E Aadd9 B E E Aadd9

4 b3 b3 b3 2 2 2 1 1 1 — — — 0 0 0 0 0 0 0 0

I can make you start to

**Guitar 2**

3 4 5 1 6 5 2 3 3 — — 3 4 5 1 6 3

Smile

B E E Aadd9 B E E Aadd9

2 3 2 1 5 1 1 — — 3 4 5 1 6 5 2 3 3 0 2 3 5 6 1 5 1 4 3 4 5 1 6 1

B E Aadd9 E Aadd9 E D

0 0 0 0 5 2 1 1 1 3 2 1 1 2 1 1 2 3 1 1 1 4 3 3 3 2 4 3 3 3 2

When It's through It's through Fate will twist the both of you so come on baby come on over

2 3 2 1 5 1 1 - - -

B G C D G G C

4 3 3 3 2 5 2 3 3 2 1 3 4 5 1 6 5 2 3 3 - - 3 4 5 1 6 3

Let me be the one to show you I'm the one who wants to be with you Deep inside I hope you

(转 G 调) Rit....

D G G C D Em G C

2 1 1 - - 3 4 5 1 6 5 2 3 3 - - 3 4 5 1 6 3

feel it too Wait-on ed a line of greens and blues Just to be the next to

D G

2 1 1 - -

be with you



3 2 2 1 1 6      5 2 3 2 1      1      1      1      1      1      1

Just to be the next to      be with you

**Rit....** **Fine**

# 一开始就没退路

词/张震岳 曲/张震岳 演唱/张震岳



$\flat$ Am



$\flat$ Am



4/4 ♩ = 119



Soul

$\flat$ Am E B

0 0 3 5 3 5  $\flat$ 6 0 3 3 3 3 3 2 2 1 1 1 2 2 7 1 1 3 3 6 5

**Bass (GT.2 Solo)**

G  $\flat$ Am E B

5 6 3 4 5 1 0 3 3 3 3 3 2 2 1 1 1 2 2 7 1 1 3 3 6 5

G  $\flat$ Am E B G

5 — — — | 6 7 7 1 1 2 6 6 7 7 1 1 — 6 5 5 5 5 3 3 2

一开始就没退路 怎么有出口





  
 2 — — — 6 7 7 1 1 2 2 6 6 7 7 1 1 — 6 5 5 5 5 1 1 7
   
 如果 不 能 说 后 悔 — 还 能 说 什 么



  
 7 — — — 6 7 7 1 1 2 2 6 6 7 7 1 1 — 6 5 5 5 5 3 3 2
   
 我 想 你 应 该 知 道 彼 此 的 想 法



  
 2 — — — 6 7 7 1 1 2 2 6 6 7 7 1 1 — 6 5 5 5 5 1 1 7
   
 爱 情 终 究 变 了 样 我 们 承 认 吧

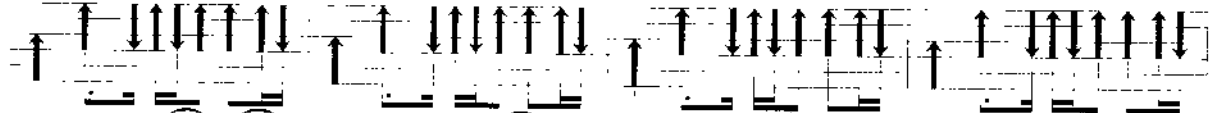

  
 7 — — — 0 2 2 2 1 1 5 2 2 2 1 3 2 2 1 0 2 2 2 1 1 5
   
 亲 爱 的 你 我 知 道 你 会 哭 泣 面 对 回 忆 我

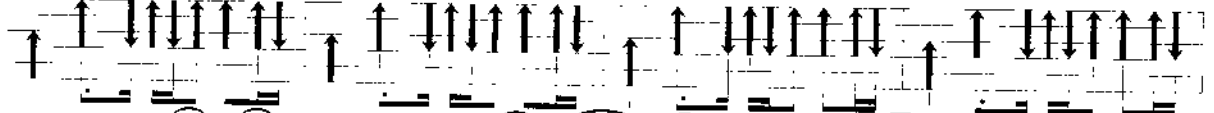

  
 2 2 2 1 3 2 2 1 0 6 6 6 5 5 5 4 4 1 1 1 6 1 3 2 2 6 6 6 6 1 6
   
 们 还 拥 有 过 去 不 要 问 我 为 什 么 我 们 承 认 吧 我 们 的





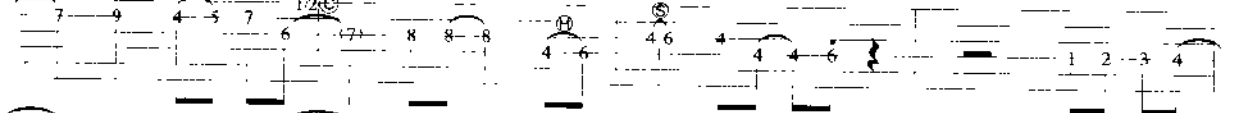

  
 3 2 1 3 2 2 1 | 0 2 2 2 1 1 5 | 2 2 2 1 3 2 2 1 | 0 2 2 2 1 1 5 |
   
 爱情已远 离 亲爱的你 我 知道你会哭 泣 面对回忆 我



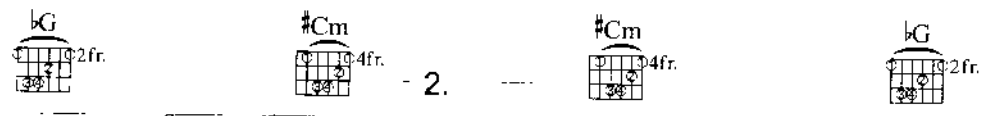
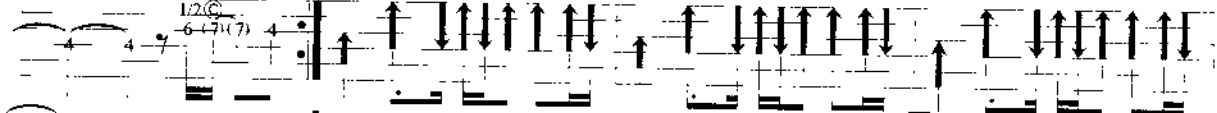

  
 2 2 2 1 3 2 2 1 | 0 6 6 6 5 5 5 | 4 4 1 1 1 6 1 3 | 2 2 6 6 6 6 1 6 |
   
 们还拥有过 去 不要问我 为什 么 我们承 认吧 我们的



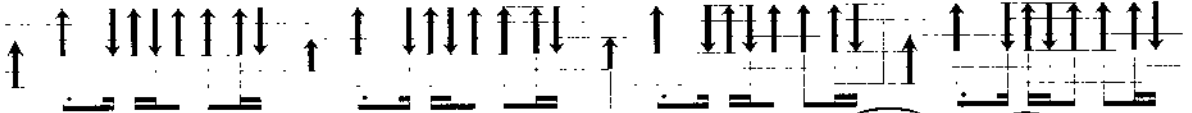

  
 3 2 1 3 2 2 1 | 0 3 3 3 3 3 2 | 2 1 1 1 2 2 7 | 1 1 3 3 6 5 |
   
 爱情已远 离 (GT.2 Solo)



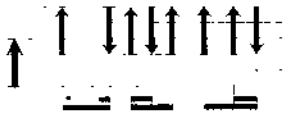

  
 5 6 3 4 5 2 | 2 3 3 3 | 5 6 2 1 5 5 6 0 | 0 0 3 4 b5 5 |



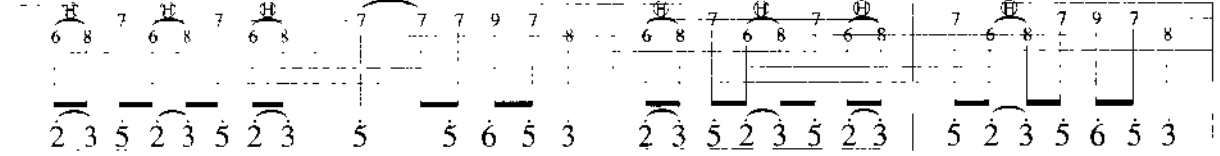

  
 5 — — — :| 0 2 2 — | 0 0 2 1 6 6 | 5 5 5 — — |
   
 时 间 慢慢 的流 动





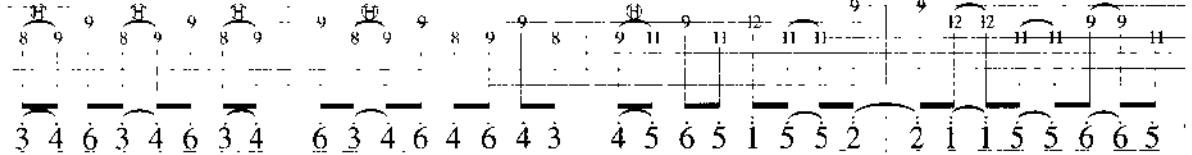

  
 0 0 0 0    0 2 2 —    0 0 2 1 6 6    5 5 5 6 —
   
 爱 你                    我 没 有 把                    握



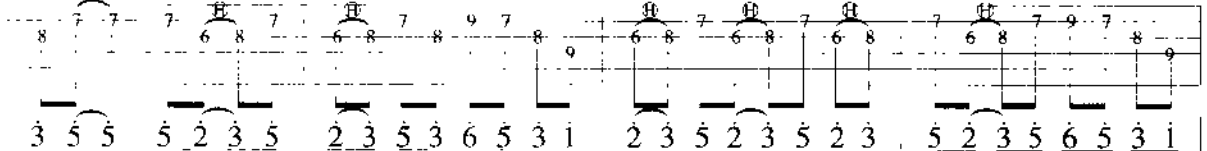



  

  
 7 — 1 —    %

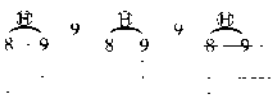

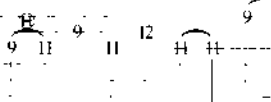
  
 6 8 7 6 8 7 6 8    7 7 7 9 7 8    6 8 7 6 8 7 6 8    7 6 8 7 9 7 8
   
 2 3 5 2 3 5 2 3    5 5 6 5 3    2 3 5 2 3 5 2 3    5 2 3 5 6 5 3

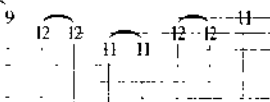



  

  
 8 9 9 8 9 9 8 9    9 8 9 9 8 9    9 11 9 11 12 11 11    12 12 11 11 9 9 11
   
 3 4 6 3 4 6 3 4    6 3 4 6 4 6 4 3    4 5 6 5 1 5 5 2    2 1 1 5 5 6 6 5

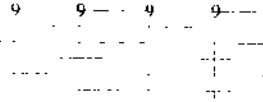

  
 8 7 7 7 7 7 6 8 7 6 8 7 6 8 7 8 9 7 8    9 6 8 7 6 8 7 6 8    7 6 8 7 9 7 8 9
   
 3 5 5    5 2 3 5    2 3 5 3 6 5 3 1    2 3 5 2 3 5 2 3    5 2 3 5 6 5 3 1

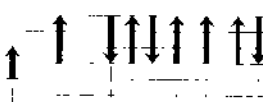



E    4fr.   2fr. 

3 4 6 4 4 6 3 4 6 3 4 6 4 6 4 3 4 5 6 5 1 5 5 2 2 1 1 5 5 1 1 3

 4fr.   2fr. 

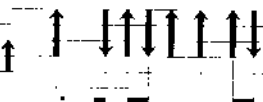

2 " 2 2 — 0 0 2 1 6 6 5 5 5 — — 0 0 0 0

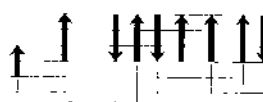
时间 慢慢地流 动

 4fr.   2fr. 



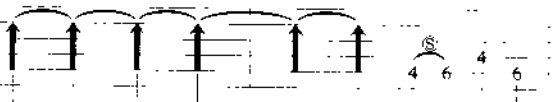

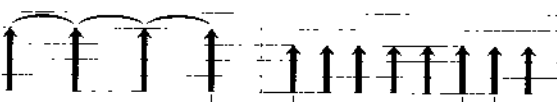
0 2 2 — 0 0 2 1 6 6 5 5 5 6 — 7 — 1 —

爱 你 我 没 有 把 握

 2fr.   4fr. 

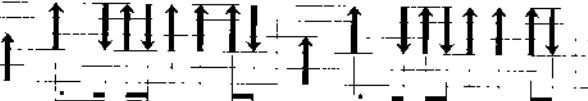
0 2 2 2 1 1 5 2 2 2 1 3 2 2 1 0 2 2 2 1 1 5 2 2 2 1 3 2 2 1

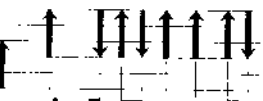

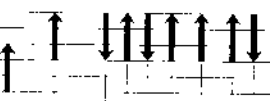
亲 爱 的 你 我 知 道 你 会 哭 泣 面 对 回 忆 我 们 还 拥 有 过 去

E    4fr.   2fr. 

0 6 6 6 5 5 5 4 4 1 1 1 6 1 3 2 2 6 6 6 6 1 6 3 2 1 3 2 2 1



不 要 问 我 为 什 么 我 们 承 认 吧 我 们 的 爱 情 已 远 离

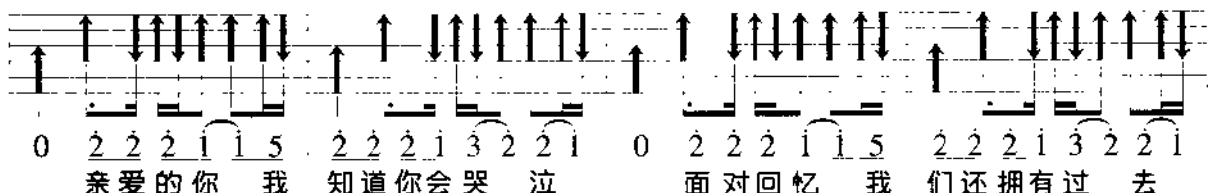

B  2fr. bAm  4fr.





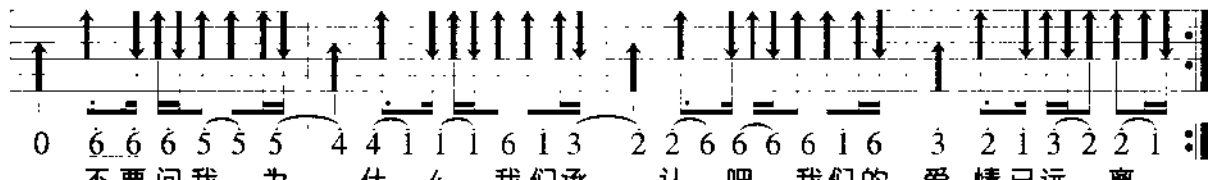

0 2 2 2 1 1 5 2 2 2 1 3 2 2 1 0 2 2 2 1 1 5 2 2 2 1 3 2 2 1  
亲爱的你 我 知道你会哭 泣 面对回忆 我 们还拥有过 去

E  #Cm  4fr. bG  2fr.





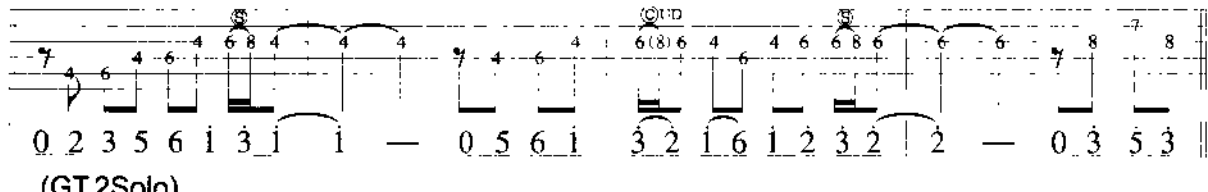

0 6 6 6 5 5 5 4 4 1 1 1 6 1 3 2 2 6 6 6 6 1 6 3 2 1 3 2 2 1 :||  
不要问我 为 什么 我们承 认 吧 我们的 爱情已远 离

bAm  4fr. (GT.1同A伴奏) E  B  2fr. bG  2fr.





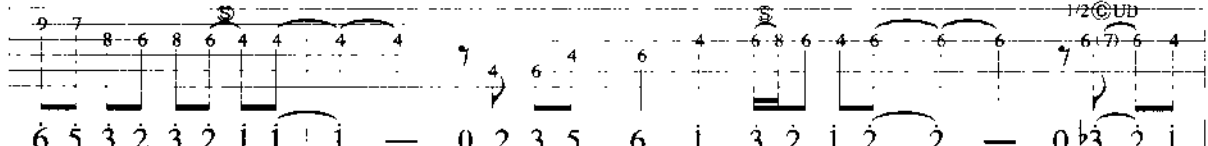

0 2 3 5 6 1 3 1 1 — 0 5 6 1 3 2 1 6 1 2 3 2 | 2 — 0 3 5 3 ||  
(GT.2Solo)

bAm  4fr. E  B  2fr. bG  2fr.



6 5 3 2 3 2 1 1 1 — 0 2 3 5 6 1 3 2 1 2 2 — 0 3 2 1 |

bAm  4fr. E  B  2fr. bG  2fr.



2 1 6 1 2 2 1 6 1 2 | 2 1 6 1 2 2 1 6 1 2 3 5 3 6 5 3 2 3 2 — 0 3 2 1 |

Chord diagrams and fret numbers:  
 - **bAm** 4fr. (Diagram: 2nd fret, 1st string; 3rd fret, 2nd string; 4th fret, 3rd string; 5th fret, 4th string; 5th fret, 5th string)  
 - **E** 4fr. (Diagram: 2nd fret, 1st string; 2nd fret, 2nd string; 2nd fret, 3rd string; 2nd fret, 4th string; 2nd fret, 5th string)  
 - **B** 2fr. (Diagram: 2nd fret, 1st string; 2nd fret, 2nd string; 2nd fret, 3rd string; 2nd fret, 4th string; 2nd fret, 5th string)  
 - **bG** 2fr. (Diagram: 2nd fret, 1st string; 2nd fret, 2nd string; 2nd fret, 3rd string; 2nd fret, 4th string; 2nd fret, 5th string)

Tablature:  
 0 6 6 6 6 6 6 6 5 5 5 5 5 6 6 5 5 — 3 3 3 2 2 — — —

Fade Out



### 切分音(拍)(Syncopation)

使用连结线将一个弱拍上的音提前或延后到下一小节的强拍上，使这个弱拍上的音变成强拍。这样延长下来的音我们就称它为「切分音」也有人直接叫它「抢拍」。

原型 | ˘ ˘ ˘ ˘ ˘ |

切分拍 | ˘ ˘ ˘ ˘ ˘ |

原型 | 1 2 3 4 |

切分拍 | 1 2 3 3 4 |



# 32 和弦动音线

## Line Cliches

「Cliches」也有人直接把它叫做“克利斜”。在音乐中则是指在一个固定和弦上做“半音”的进行，为的是不要让声部太和谐，也可以说是刻意让和弦有一种“冲突”的感觉。这样的半音进行可以发生在和弦的高音部，也可以在和弦的低音部：这种手法在各种的音乐型态里经常会被拿出来用，在国内的流行歌里更是不胜枚举。不用多说，下面我们来看看几种Cliche Line的做法！

### 一、将Cliche Line放在高音的声部(6- #5-5- #5)

#### ▶ 范例一

Am (5fr.)    Am#5 (4fr.)    Am6 (3fr.)    Am#5 (4fr.)

### 二、将Cliche Line放在中音的声部(6- b6-5- b5)

#### ▶ 范例二

Aadd9 (5fr.)    Amaj7 (5fr.)    A7 (5fr.)    A6 (4fr.)

Dm6/A    Aadd9    Bm7 (2fr.)    E



### 三、将Cliche Line放在根音的声部(6- $\flat$ 6-5- $\flat$ 5)

#### ▶ 范例三

Am 5fr. Am/bA 5fr. Am/G 5fr. Am/bG 4fr. Fmaj7 G 3fr. Cmaj7 E

#### ▶ 范例四

Am 5fr. Am9/bA 5fr. Am/G 5fr. A69/bG 2fr. Fmaj7 Am

好，你是不是已经体验到这种“飘渺、诡谲、悬疑”的效果了，你也可以试着在你所会弹的歌曲中，试着加入这种Line Cliches的效果，因为通常谱上是不会写出和弦的变化(除非原曲就是这种弹法)，但是如果你学过这些弹法，你便可以在一些停留比较久的和弦或者是怕弹得太单调的和弦上，运用它，大调和弦与小调和弦都可以使用(不过在小调和弦上用的机率较多)，久了就会变成一种习惯了，弹吉他的变化就多了。



# If

Bread

**A**  
Key

**A**  
Play

**4/4**  
Tempo

<b>A9</b>  6fr.	<b>Em/G</b>  4fr.	<b>Em/G</b>  4fr.	<b>D69/#F</b>  2fr.
-----------------------	-------------------------	-------------------------	---------------------------

0 0 0 0 | 0 0 0 0 | 0 0 0 0 | 0 0 0 0

<b>Dm9/F</b> 	<b>A/E</b>  2fr.	<b>Dm6/F</b> 	<b>E7</b> 
------------------	------------------------	------------------	---------------

0 0 0 0 | 0 0 0 0 | 0 0 0 0 | 0 0 0 0 | 0 0 0 3 4 |

If a

<b>A9</b>  6fr.	<b>Em/G</b>  4fr.	<b>Em/G</b>  4fr.	<b>D69/#F</b>  2fr.
-----------------------	-------------------------	-------------------------	---------------------------

5 5 5 5 | 5 4 3 3 | 4 5 5 5 | 4 4 3 | 1 — — | 1 4

pictré paints a thou-sand words Then why can't I paint you you The words  
 man could be two pla - ces at onc time I'd be with you tomor-

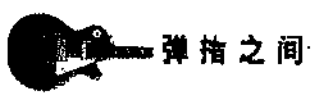

Dm9/F

A/E 2fr.

Dm6/F

E7

Will never show The you I've come to know If a  
-row and to-day Beside you all the way If the

A9 6fr.

Em/G 4fr.

Em/G 4fr.

D69/F 2fr.

face could launch a thou - sand ship's Then where am I to go There's no  
world should stop revolv-ing spinning slow - ly down to die I'd

Dm9/F

A/E 2fr.

Dm6/F

E7 1.

one home but you You're all that's left me too And when  
spend the end with you And when the world was through

#Fm 2fr.

#Fm/F 2fr.

A6/E

D6

my love for life is run- ning dry You

#Cm7-5 4fr.





#E7 2fr.

Bm7 2fr.

E7





come and pour your - self on me If a



E7  2.  2fr.  2fr. 





2 — — 1 3 — 3 6 6 7 7 — — 1 3 3 3 2 1 2 2

Then one by one the stars would all go out

D6   4fr.  2fr.  2fr.

2 — — 6 5 — — 2 b2 | b2 — — 5 | 4 — — 5

Then you and I would simply

E7   6fr.  2fr. 

6 — — 7 1 — — 1 — — 0 2 0 0 2 0

fly a way

A 

0 0 0 0

Fine





# 解脱

词/姚若龙 曲/许华强 演唱/张惠妹



4/4 = 82



Slow Soul



各弦调降半音

D9     
 D9/C     
 D9/B

D9/A     
 D9/G     
 D9/F#     
 Em7

Asus4     
 D9     
 D9/C     
 D9/B





0 0 0 0 | 5 1 3 3 4 4 3 3 | 5 1 3 3 4 4 3 3 | 5 1 3 3 4 4 3 1 1 2

2 - 5 6 1 2 3 1 | 1 2 2 3 1 2 2 1 1 | 1 - 3 4 5 | 6 - 0 2 3 2 3

2 - - - | 0 2 2 2 2 3 3 1 2 | 2 2 2 2 2 3 3 1 2 | 1 - - -





爱是不夜 城 回忆像星 辰



D9/A  2fr.      D9/G       D9/#F  2fr.      Em7 





0 2 2 2 2 3 3 1 2 | 2 2 2 2 3 3 4 5 | 5 2 3 2 2 2 -

热泪越沸 腾 我越 感觉 有 点 冷

Asus4       D9       D9/#C  2fr.      D9/B  2fr.





0 0 0 0 | 0 2 2 2 2 3 3 1 2 | 2 2 2 2 2 3 3 1 2 | 1 - 0 5 6 6 5 6

变了心的 人 越想越伤 人 耶.....

D9/A  2fr.      D9/G       D9/#F  2fr.      Em7 





5 - - - | 0 2 2 2 2 3 3 2 2 | 2 2 2 2 2 3 3 5 | 5 - 0 3 3 2

枯坐 到清 晨 阳光 替房 间 开了灯

Asus4       D9/G       D9/#F  2fr.      Em7 

2 - - - | 1 · 1 1 2 3 1 | 1 · 1 1 2 2 3 | 2 1 6 6 - 0 5 6

想 若 结局 一样 又何必 再 想 耶.....

Asus4       D9/G       D9/#F  2fr.      Em7 

5 - - - | 1 · 1 1 2 3 1 | 1 · 1 1 2 3 5 | 5 - 0 2 3 3 2

伤 若 让人 成长 我 为什 么 怕 分 手的

Asus4



D9



D9#C



D9/B



2 3. 3 - i 5 - 3 4 5 5 5 4 4 3 3 2 2 5 4 5 - 3 4 5 5

伤 解 脱 是肯 承 认 还 是 个 错 我 不 应 该

D9/A



D9/G



D9#F



Em7



5 i i 3 3 2 i . 2 2 . i i 2 3 i | i . i i 2 3 5 | 5 2 3 3 2 2 -

还 不 放 手 你 有 自 由 走 我 有 自 由 好 好 过

♣ Asus4



D9



D9#C



D9/B



- - - i 5 - 3 4 5 5 | 5 4 4 3 3 2 2 5 4 5 - 3 4 5 5 |

解 脱 是 懂 擦 干 泪 看 以 后 找 个 新 方

D9/A



D9/G



D9#F



Em7



5 i i 3 3 2 i . 2 2 . i i 2 3 i | i . i i 2 3 5 | 5 - . 3 3 2 |

向 往 前 走 这 世 界 辽 阔 我 总 会 实 现 一 个 梦

Asus4



D9



D9#C



D9/B





2 - - - | 0 . 2 2 - | 0 0 . 2 3 2 1 2 | 1 - - . 5 6

耶 ——— 耶 ———



D9, A  2fr.

D9/G  2fr.

D9/#F  2fr.

Em7  0fr.

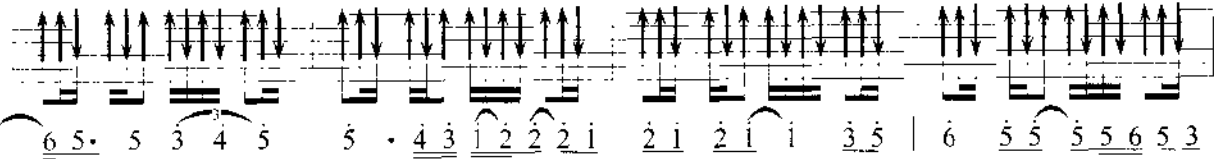

6 5 . 5 3 4 5 | 5 . 4 3 1 2 2 2 1 | 2 1 2 1 1 3 5 | 6 5 5 5 5 6 5 3

Acoustic Guitar Solo

Asus4  2fr.





5 6 1 b3 1 2

§

Asus4  2fr.

Bm  7fr.

Bm/A  7fr.

Bm/A  7fr.

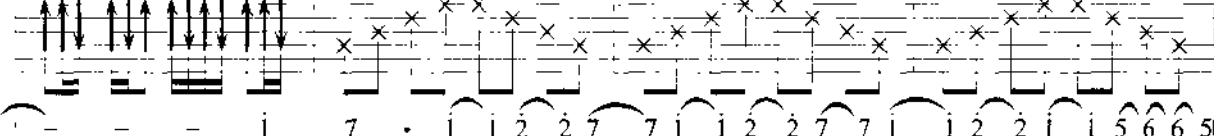



— — — — — | 7 . 1 1 2 2 7 | 7 1 1 2 2 7 7 1 | 1 2 2 1 1 5 6 6 5 |

心 里 有 一 种 渴 望 勇 敢 的 念 头 ——

Bm/A  6fr.

D69/#F  3fr.

Asus4  2fr.

D9  2fr.



6 5 6 6 — 1 5 — 3 4 5 5 | 5 1 1 3 3 2 2 6 | 2 2 1 0 1 7 5 |

不 要 爱 我 的 人 在 担 心 我 ——

Asus4  2fr.

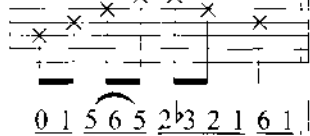

0 1 5 6 5 2 b3 2 1 6 1 |

Repeat 副歌

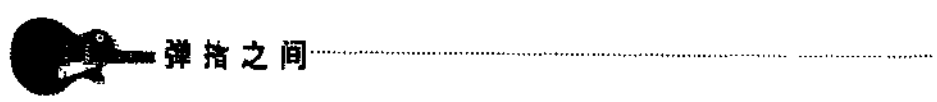

# 爱我别走

词/张震岳 曲/张震岳 演唱/张震岳



Key



Play



4/4 ♩ = 92

Tempo



Rhythm

Slow Soul

Cadd9 Cadd9/B

0 0 0 0 | 0 0 0 0 | 1 5 2 3 3 5 2 5 7 5 2 3 3 5 2 5

Drum

Cadd9/B Am7 #Gmaj7 Gm7

b7 5 2 3 3 5 2 5 | 6 6 1 5 5 6 1 6 | #5 5 1 b3 b3 - | 5 5 b7 2 2 -

Cadd9 Cadd9/B Cadd9/B

0 0 0 0 | 0 5 5 5 5 5 5 5 5 4 4 3 3 - | 0 5 5 5 5 5 5 5

我 到 了 这 个 时 候 还 是 一 样 夜 里 的 寂 寞 容 易



Am7 Dm7 G Cadd9

5 4 3 1 1 - | 0 4 4 4 4 3 4 1 | 1 - 0 1 1 1 | 2 3 3 - -

教人 悲伤 我 不敢 想得 太多 因为 我 一个人

G Cadd9 Cadd9/B Cadd9/B

0 0 0 0 | 0 5 5 5 5 5 5 5 | 5 4 4 3 3 - | 0 5 5 5 5 5 5 5

迎 面 而 来 的 月 光 拉 长 身 影 漫 无 目 的 地 走 在

Am7 Dm7 G Cadd9

5 4 3 1 1 - | 0 4 4 4 4 3 4 1 | 1 - 0 1 1 1 | 2 3 3 - · 5 6

冷 冷 的 街 我 没 有 你 的 消 息 因 为 我 在 想 你 耶

Gsus4 C Em7/B Am Am7/G Dm7 Dm7/G

5 · 3 3 1 6 5 | 0 3 2 2 3 1 | 1 1 7 7 6 6 | 0 1 3 2 1 1 3

爱 我 别 走 如 果 你 说 你 不 爱 我

Cadd9 E7 Am7 Dm7

3 - - - | 0 3 3 3 3 3 3 3 | 4 3 2 1 1 6 6 4 | 4 3 3 1 1 3 3 2

不 要 听 见 你 真 的 说 出 口 再 给 我 一 点 温 柔



G9sus4 C Em7/B Am Am7/G Dm7 Dm7/G

2 - - - | 0 3 2 2 3 1 1 1 7 7 6 6 | 0 1 3 2 1 1 3

爱我 别走 如果 你说 你不 爱我

Cadd9 E7 Am7 Dm7 G

3 - - - 0 3 3 3 3 3 4 3 2 1 1 6 6 4 4 3 3 1 1 2 1 1

不要 听见 你真 的说出 再给我 一点 温柔

Cadd9 Cadd9 1. Cadd9 2. Cadd9/B

1 - - - 0 0 0 0 | 0 3 3 3 3 3 3 2 2 1 0 5 6 3

G.T. Solo (伴奏同前奏)

Cadd9/B Am7 #Gmaj7 Gm7

9 9 9 9 8 10 9 9 7 5 7 5 5 7 5 5 4 6 8 9 8 10 8 10 13 12 13 12 10 9 5

0 3 3 3 5 6 1 3 | 2 1 2 1 | 0 3 4 6 1 2 3 4 6 | 7 6 4 3 3 3 1 6 4 4 3 1 1

C G

9 7 5 5 7 5 7 7 9 10 8 9 7 7 5 7

1 3 2 1 1 2 1 2 | 0 2 3 6 5 3 2 2 1 2

§







# 秘密

词/张震岳 曲/张震岳 演唱/张震岳

● Key Am ● Play Am ● Tempo 4/4 ● Picking | xx ↑x xx ↑x | ● Fingers | T1 32 T1 32 |

Am Am/A Am/G Am/bG Fmaj7 G6 Cmaj7 E/B

6 1 6 3 6 1 6 3 5 1 6 3 4 1 6 7 4 6 3 1 5 7 3 7 | 1 3 3 7 7 3 3 7 |

Am Am/A Am/G Am/bG Fmaj7 G Cmaj7 E/B

6 7 7 1 1 2 2 3 2 2 2 1 7 7 7 7 6 1 1 7 5 5 5 3 3 3 — — —

总在闭上双 眼之后 才能看见你

Am Am/A Am/G Am/bG Fmaj7 G Cmaj7 E/B

6 7 7 1 1 2 2 3 2 2 2 2 1 7 7 7 7 6 1 1 7 7 5 5 3 2 3 — — 1 2

这是一个心中秘密 偷偷在爱你 你却

Dm7 Dm7/G C E

3 3 2 2 — 0 0 5 6 1 2 1 1 — — — | 0 0 0 0

不知道 有人在想你

Am Am/A Am/G Am/bG Fmaj7 G Cmaj7 E/B

6 7 7 1 1 2 2 3 2 3 2 2 1 7 7 7 7 6 1 1 7 5 5 5 3 3 3 — — —

总在黎明来临之前 我还是清醒

Am Am/A Am/G Am/bG Fmaj7 G Cmaj7 E/B

6 7 7 1 1 2 2 3 2 3 2 2 1 7 7 7 7 6 1 1 7 5 5 5 3 3 3 — — 1 2

什么时候我才可以 进入你的心 好想



Dm7 Dm7/G C E

3 3 2 2 — 0 0 5 6 1 2 1 — — — 0 0 0 0

对你说 我 正在 想你

Dm7 Dm7/G C Em7/B Am Am7/G

0 4 4 4 4 4 4 4 | 4 4 4 4 4 3 2 1 | 0 3 3 3 3 2 2 1 | 2 2 2 1 2 1 6 1

也许在你的心中 早就已经有人进去 或许你不曾接受 真正的爱 真诚的情

Dm7 Dm7/G C

0 2 2 1 3 3 3 2 | 0 0 5 5 6 5 5 3 3 — — — 3 . 3 2 1 1

遗忘吧过去的事 不要再怀疑 耶...

Dm7 Dm7/G C Em7/B Am Am7/G

0 4 4 4 4 4 4 4 | 4 4 4 4 4 3 2 1 | 0 3 3 3 3 2 2 1 | 2 2 2 1 2 5 3 1

我仿佛可以听见 你的心跳 你的声音 不要只有在梦中 才能看你才能靠近

F Dm7 G G

0 2 2 1 3 3 3 2 | 2 0 6 1 3 3 2 2 2 — — — 2 — — —

我可以慢慢地等 直到你离去

Am Am/bA Am/G Am/bG Fmaj7 G Cmaj7 E/B

0 6 1 2 3 — | 0 3 2 1 6 1 . 2 3 5 5 6 5 3 2 3 — 0 3 3 2

Am Am/bA Am/G Am/bG Fmaj7 G Cmaj7 E/B

3 5 5 6 7 7 1 | 2 1 2 3 . 6 1 2 3 2 1 6 1 2 3 2 1 i — — —

Dm7 Dm7/G C Em7/B Am Am7/G

0 4 4 4 4 4 4 4 | 4 4 4 4 4 3 2 1 | 0 3 3 3 3 2 2 1 | 2 2 2 1 2 1 6 1

也许在你的心中 早就已经有人进去 或许你不曾接受 真正的爱 真诚的情

F Dm7 G G

0 2 2 1 3 3 3 2 | 0 0 0 1 1 1 1 5 6 5 5 — — | 0 0 0 0

遗忘吧过去的事 不要再怀疑

Dm7 Dm7/G C Em7/B Am Am7/G

0 4 4 4 4 4 4 4 | 4 4 4 4 4 3 2 1 | 0 3 3 3 3 2 2 1 | 2 2 2 1 2 5 3 1 |

我仿佛可以听见你的心跳你的声音 不要只有在梦中才能看你才能靠近

F Dm7 G G

0 2 2 1 3 3 3 2 | 2 0 6 1 3 3 2 2 2 — — | 2 — — — —

我可以慢慢地等 直到你离去

Am Am/bA Am/G Am/bG Fmaj7 G Cmaj7 F/B

Am Am/bA Am/G Am/bG Fmaj7 G Cmaj7 E/B

Am Am/bA Am/G Am/bG Fmaj7 G Cmaj7 E/B

Am Am/bA Am/G Am/bG Fmaj7 G Cmaj7 E/B

0 3 6 3 7 6 3 6 | 6 3 6 3 7 6 3 6 | 6 7 7 1 2 1 2 | 2 1 1 2 1 6 1 |

0 3 6 3 7 6 3 6 | 6 3 6 3 7 6 3 6 | 6 1 6 5 2 3 5 5 6 1 | 2 1 2 3 3 5 6 6 :

Fade Out



# 33 级数与顺阶和弦

## Diatonic Chord

在前面章节的歌曲练习中，相信你一定弹过了几种不同调性的和弦了，但是在这些调性中，是不是有一些脉络可循，或者说如果今天有一首歌你是弹C调的，但是有一天突然要叫你用G调弹这首歌，你是不是可以很快地找出和弦的配置。

别想得太恐怖！把下面的表格看懂，问题就解决了。

如果我们在一个C大调音阶中，再推叠二个三度音的音阶，那么在纵向便会行成一组和弦，这一组和弦我们就称它为「顺阶和弦」。

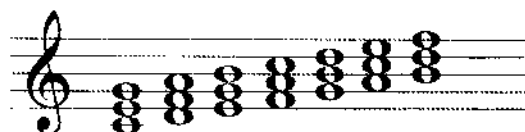

5	6	7	1	2	3	4
3	4	5	6	7	1	2
1	2	3	4	5	6	7
C	Dm	Em	F	G	Am	Bdim

为了方便这称呼这组和弦，我用级数 1. 2. 3. 4. 5. 6. 7 来称呼他们，1级是C和弦，4级是F和弦，6级就是Am和弦了。

级数	1 I	2 II	3 III	4 IV	5 V	6 VI	7 VII
和弦	C	Dm	Em	F	G	Am	Bdim



如果我再把各调的顺阶都写进来，看看会变怎样

级数	1 I	2 II	3 III	4 IV	5 V	6 VI	7 VII
C调	C	Dm	Em	F	G	Am	B <sup>-</sup>
G调	G	Am	Bm	C	D	Em	#F <sup>-</sup>
D调	D	Em	#Fm	G	A	Bm	#C <sup>-</sup>
A调	A	Bm	#Cm	D	E	#Fm	#G <sup>-</sup>
E调	E	#Fm	#Gm	A	B	#Cm	#D <sup>-</sup>
F调	F	Gm	Am	<sup>b</sup> B	C	Dm	E <sup>-</sup>
B调	<sup>b</sup> B	Cm	Dm	<sup>b</sup> E	F	Gm	A <sup>-</sup>

请注意，以上仅列出三和弦的顺阶，当然也有七和弦的顺阶，请你自己推算一下。每个调性不同，变音记号就会有所不同，至于变音记号的秘诀，请参照本书第42章「五度圈」单元。至于级数则是专业人士的共通术语，因为常常需要配合演唱者而演奏多种的调性，用这样称呼就方便多了。举个例子，D调的3级是#Fm和弦、A调的5级是E和弦、F调的6级是Dm和弦，你可以自动弹成七和弦，那和弦就变成#Fm7、Emaj7、Dm7。



# 因为

词/非非 曲/非非 演唱/范玮琪



B



G



3



4/4, = 126



Soul

Cmaj7/E



G/B



0 0 0 0 0 0 0 0 0 0 0 0 0 0 0 0 0 0

Am7



Dsus4



G



0 0 0 0 0 0 0 0 0 0 0 0 0 0 0 0 0 0

G



D#F



Em



0 5 5 5 5 5 4 5 4 4 3 3 2 2 2 2 1 1 1 1 0 0 0 0

总在我家巷 □和你分手



弹指之间

C G/B Am7 Dsus4

0 6 7 6 7 1 1 1 5 5 — 1 2 3 3 3 3 3 3 1 | 3 2 2 — — |

仿佛偶像剧一 样 觉得 我们就要发生 些 什么

G D#F Em

0 5 5 5 5 5 4 5 4 4 3 3 2 2 | 2 1 1 1 1 — | 0 0 0 0 |

总在回家 时 候不 知 所 措

C G/B Am7 D

0 6 7 6 7 1 1 1 5 5 — 1 2 3 3 3 3 3 3 1 | 3 2 2 — — |

想在打电话给 你 可是 再见 刚刚 才 说过

Em Em11/E Em/D #Cm7-5 4fr.

0 0 6 6 7 1 2 3 1 1 3 3 2 2 | 2 1 1 — | 0 0 0 0 |





有一种想要 拥 抱你 的冲 动

C G Am7 Am7





0 0 6 6 7 1 2 2 1 1 1 1 5 1 2 | 3 3 3 3 3 3 3 3 3 3 3 3 1 |

想静静看着 你 的笑 容让你 藏 在怀 中直 到我每天 的







Dsus4       D       G       D/F# 





3 2 2 2 2 — 0 0 3 4 | 5 5 5 3 5 5 3 3 5 5 5 1 2  
 尽头      **Rit.....**      因为      想一个人而寂寞      因为

Em       Bm7  2fr.      C       G 



2 1 1 7 1 1 6 6 5 5 — 5 5 | 6 5 5 5 5 5 3 1 1 1 — 1 1 |  
 爱一个人而温柔      因为有一个梦而执着      因为

Am7       D       G       D/F# 

3 1 1 1 1 6 3 3 2 3 2 2 — 3 4 5 5 5 3 5 5 3 | 3 5 5 — 1 2 |  
 等一个人而折磨      因为想一个人而解脱      因为

Em       Bm7  2fr.      C       G 

3 2 2 1 1 2 6 | 5 — — 5 5 6 7 7 1 1 1 5 5 1 — 1 1 |  
 爱一个人而宽容      因为有一个梦而放纵      因为

Am7       D       G 

3 2 1 2 2 — 0 0 0 0 1 2 1 1 1 1 — 0 0 0 0 |  
 等一个人      而漂泊





**Guitar 1 simile**

Chords: G, D/F, Em, Em/D

0 0 1 3 5 1 2 | 2 3 3 5 5 5 | 1 3 3 3 — | 0 0 1 1 7 5 5 3 |

哒 哒

**Guitar 2**

Chords: C, G/B, Am7, D

4 — — — | 0 0 0 0 | 0 0 0 0 | 0 0 7 1 2

哒

Chords: G, D/F, Em, Em/D

2 3 3 3 3 3 | 4 3 3 5 5 5 4 3 | 2 1 1 1 — | 0 0 0 0

呜

Chords: C, G/B, Am7, D

0 0 0 0 | 0 0 0 0 | 0 2 3 4 6 1 2 3 | 2 — 7 1 2 :||

哒

Chords: Am7, D, G, D/F

3 2 2 1 1 6 3 | 3 2 3 2 2 — | 3 4 | 5 5 5 3 5 5 3 3 | 5 5 5 1 2

等一个人而漂泊 因为想一个人而寂寞 因为



Em Bm C G Em

3 2 2 1 1 2 2 6 6 5 5 5 0 5 6 5 5 5 1 3 4 5 3 2 2 1 6 7

爱一个人而温柔像夜的朦胧你的深情难懂我的

Am7 D G D#F

1 1 1 1 1 6 3 3 2 3 2 2 3 4 5 5 5 3 5 5 3 3 5 5 — 1 2

世界因为你而不同因为想一个人而解脱因为

Em Bm7 C G Em

3 2 2 1 2 3 3 6 6 5 5 5 0 5 6 5 5 5 1 3 4 5 3 2 2 1 6 7

爱一个人而宽容像风的自由你的深情难留你的

Am7 D Cmaj7 Em7

1 6 6 — — 0 1 1 1 1 7 6 7 2 1 1 7 1 1 — 0 — 0 0

背影是我最美丽的所有

Am7 Dsus4 G G G

0 0 0 0 0 0 0 0 0 0 0 0 0 0 0 0 0 0

Fine



# 如果有一天

词/易齐 曲/郭文贤 演唱/梁静茹



D



D



4/4 . = 98



Slow Soul

D A Bm7 A G A

5 1 7 1 5 1 7 1 2 7 6 7 5 7 6 7 1 6 5 6 5 4 3 5 4 3 2 5 6 5 6 7

D D G

1 5 4 3 3 1 2 5 1 — — — 1 2 1 1 7 1 3 3 6 3 — —

现在心 是能欣 赏

D G Dadd9 Asus4#C

0 1 2 1 1 7 1 6 6 6 6 — 0 5 5 3 3 4 4 5 5 6 5 2 2 0 2 2 3

惟一的 合照一 张 淡 忘 了 的 是 那 个 街 角 想 念 的



Em A D G

4 3 4 5 5 3 2 2 2 — — — — — | 1 2 1 7 1 3 3 3 3 — — — — —

是当时的微笑 生活中交错失望

D G D Aadd9#C

1 2 1 1 7 1 6 6 6 6 — 0 5 5 3 3 4 4 5 5 6 5 2 2 0 2 2 3

越想念就越孤单 若再被寂寞迎头赶上多感伤

Em9 A D D G A D

4 3 4 5 0 2 1 1 — — — — — | 1 3 2 2 5 5 3 3 5 5 6 1 1

原来只是正常 你是不是也在品尝

Em7 A D G A D Bm7

0 6 3 2 2 1 1 2 3 5 5 5 3 3 — 3 3 2 2 1 1 2 3 5 5 6 6 1 1

一个人的咖啡和天光 是不是也忽然察觉到

Em9 Em9 A A A A

0 3 2 2 1 6 6 6 6 6 5 5 5 — — — — — | 5 5 4 4 3 4

多出时间看 天色的变化 如果有一

D A#C Bm #Fm

5 5 4 4 4 3 2 2 3 2 2 2 3 1 6 7 6 6 3 3 5 4 4 3 4

天 我 们 再 见 面 时 间 会 不 会 倒 退 一 点 也 许 我 们

Em9 A G D A G

5 1 1 6 4 3 2 2 1 2 1 3 3 3 5 4 4 3 4

都 忽 略 互 相 伤 害 之 外 的 感 觉 如 果 哪 一

D A#C Bm #Fm

5 5 4 4 4 3 2 2 2 2 3 2 1 1 1 7 6 5 3 3 5 4 4 3 4

天 我 们 都 发 现 好 聚 好 散 不 过 是 种 遮 掩 如 果 我 们

Em9 A G D D G #Fm

5 1 1 6 4 3 2 4 3 7 2 1 1 1 1 1 1 1

没 发 现 就 给 彼 此 多 一 点 时 间

Em Em Em #Fm G A

Guitar Simile

0 3 3 2 2 6 6 0 3 3 2 3 4 4 5 1 5 5 1 1

Guitar 2 solo



D A/C Bm F#m

10 12 12 14 14 12 10 12 12 10 10 12 14 12 11 10 12 8 9 9 11 12 12 10 12 10 12 11 12 3 10

1 2 3 3 2 1 2 2 5 5 5 4 3 1 2 7 7 3 6 6 5 6 6 4 3 4 5

G Em A D

12 12 12 12 12 9 11 10 12 9 11 9 9 7 9 11 11 7 7 5 4 4 4 4

4 1 1 5 3 5 5 6 3 3 2 2 1 2 3 1 1 4 3

D G A

1 1 1 0 0 5 4 3 4

间 如果有一

Em9 A G D D

5 1 1 6 4 3 2 4 3 7 7 7 2 1 1 1

没发现 就给彼此多 一点 时间

F#

1 3 1 1 7 5

Rit... Fine



# 开始懂了

词/姚若龙 曲/李德松 演唱/孙燕姿



B



A



2



4/4, = 60



Slow Soul

Aadd9



E



Bm7



2fr.

Aadd9



E



Bm7



2fr.

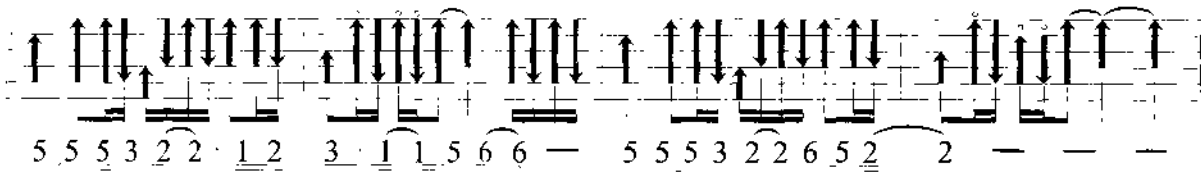

(EG. Clean)

Aadd9



Aadd9#F



#Cm7



4fr.

Dadd9



Bm7



2fr.

Esus4



E

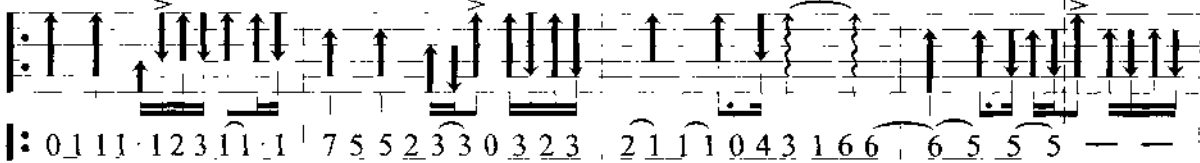

我竟然没有掉头在 残忍那一刻 静静看 你走 一点都不像 我

Aadd9



Aadd9#F



#Cm7



4fr.

Dadd9



#Cm7



4fr.

Bm7



2fr.



原来人会变得温柔 是 透彻地懂了 爱情是 流动的 不由人的 何必激动着 要理



Esus4 E Aadd9 E #Fm #Cm7 Dadd9 #Cm7

6 5 5 0 5 5 4 3 4 | 5 6 5 5 3 5 6 5 5 2 | 0 1 1 7 6 5 3 5 — | 0 1 1 7 6 5 3 5 3 2 1

由 相信你只是 怕伤害 我不是骗 我 很爱过谁会舍得 把我的梦摇醒了宣布幸

Bm7 E Aadd9 E #Fm Em7 A7 Dadd9 #Cm7

2 3 6 6 3 2 2 5 5 4 3 4 | 5 6 5 5 3 5 6 5 5 2 | 0 1 1 2 7 5 3 6 5 5 | 0 1 1 7 6 5 3 5 3 2

福不会来了用心酸微笑去原谅了也翻越了 有昨天还是好的 但明天是自己的开始

Bm7 E Aadd9 E #Fm

1 2 2 0 4 3 1 | 2/4 6 1 1 | 5 5 5 3 2 2 1 2 | 3 1 1 5 6 6 —

懂了 快乐是 选择 (EG. Clean)

E Aadd9 Bm7 Dadd9 #Cm Bm7 E

5 5 5 6 1 1 3 5 2 | 2 — — — :| 0 1 1 7 6 5 3 5 3 2 | 1 2 2 0 4 3 1

但明天是自己的开始 懂了 快乐是

Dadd9 #Cm Dadd9 #Fm E

6 1 1 0 5 4 1 | 6 5 2 0 5 3 6 | 6 — — — | 6 5 2 1 2 7 6

选择 哈 耶





Bm7 (2fr.)    #Cm7 (4fr.)    D    E

6 — — 2 2 3 3 5 5 5 3 : 0 1 1 3 3 2 2 3 5 5 2 0 5 5 4 3 4

(EG.)      喔—耶 相信你只是

Aadd9    E    #Fm (2fr.)    #Cm7 (4fr.)    Dadd9    #Cm7 (4fr.)    Bm7 (2fr.)    E

5 6 5 5 3 5 6 5 5 2 : 0 1 1 7 6 5 3 5 — 0 1 1 7 6 5 3 5 3 2 1 2 3 6 6 5 3 2 5 5 4 3 4

怕伤害 我 不是骗 我 很爱过谁会舍得 把我的梦摇醒了宣布幸福不会来了 心酸微笑

Aadd9    E    #Fm (2fr.)    Em7    A    Dadd9    #Cm7 (4fr.)    Bm7 (2fr.)    E

5 6 5 5 3 5 6 5 5 2 : 0 1 1 2 7 5 3 6 5 5 0 1 1 7 6 5 3 5 3 2 1 2 2 0 4 3 1 6

去原谅 了也翻越 了 有昨天还是好的 但明天是自己的开始 懂了 快乐是选

Rit.....

Aadd9    E    Bm7 (2fr.)    Aadd9    E    Bm7 (2fr.)

2 : 1 6 5 2 2 0 3 2 1 2 : 6 6 1 1 — 5 5 5 6 5 2 2 0 3 2 1 2 : 6 6 — —

择 (E.G. Clean)

Aadd9    E    Bm7 (2fr.)

5 5 5 6 5 2 2 0 3 2 1 2 — — —

Fine



















# 34 简易吉他编曲

一首曲子的特色，除了在于曲子的动听之外，与弹奏者对于曲子的处理有很大的关系。谈到曲子的处理，我想前奏、间奏与尾奏是特别值得研究的地方。

在前面几章的练习当中，大家应该都是注重在弹唱的配合，但是我想你在弹唱当中可能会发生一些问题，譬如说：前奏应该弹几小节？间奏又该如何处理？如何结束？在本章里将针对前奏与间奏的基本编奏来做一番说明，至于和弦的配置、连接与修饰在以下几个单元中会有更深入的探讨，本章就只针对编奏来探讨。相信大家弹过这几章后，会发现吉他将不仅仅只是伴唱的工具而已。

一、编曲的第一步，当然必须要先有谱，乐谱的取得可以是自己抓(采谱)、或是使用现成乐谱，都可以。并且已配上基本和弦。

以下的范例，笔者找了一首吴宗宪专辑里的一首曲子叫“真心换绝情”，原曲的前间奏是用古筝弹的，我把他抓下来，并用吉他来表现。

Am	Em	F	F	Fm	C	G	C	Am
								
0 0   7 6 5   3 — 6 5 3 2   1 — — 1 2   3 · 3 2 1 6 5   2 3 3 1 7 6 5								
Em	F	F	Fm	C	G	C	C	
								
3 — 6 5 3 2   1 — — 1 2   3 · 3 2 1 6 5   1 — 0 4 3 1 6   5 — — —								

二、有了谱之后，你必须决定要用甚么节奏型态来弹，这点要考验你对前面几章的音乐形态是否了解透彻，甚么是Slow Soul、甚么Slow Rock，是你必须要很清楚的。当你决定了节奏型态的弹法后，还有一点，像这种单音加和弦的弹法，你只要选择最基本的指法即可，指法上的音可以说是当做旋律空拍上的“补音”。

选择指法：

| 1 2 1 3 1 2 |



弹指之间

### 三、简单划一张六线谱纸，将旋律与和弦根音先填上。

实际编曲时，为了弹奏上和声的需要，通常会把旋律音提高八度或者让旋律线与根音或指法尽量错开，这样编出来的曲子通常会比较好听。

Am 5fr. Em Fmaj7 3fr. F Fm C G C Am 5fr.

8 7 5 8 | 0 — 5 3 5 3 | 1 — 1 3 0 — 3 1 2 0 | 3 — 0 8 7 5 8

0 0 1 7 6 5 || 3 — 6 5 3 2 | 1 — — 1 2 3 · 3 2 1 6 5 | 2 3 3 1 7 6 5

Em Fmaj7 3fr. F Fm C G C C

0 — 5 3 5 3 | 1 — 1 3 0 — 3 1 2 0 | 3 — 0 8 7 5 8

3 — 6 5 3 2 | 1 — — 1 2 3 · 3 2 1 6 5 | 1 — 0 4 3 1 6 5 — — —

### 四、在旋律空拍处补上指法的音即可，遇到指法与旋律冲突时，指法处如有旋律就以旋律为主，其余指法补到空拍处。除非旋律需要，否则避免在同一弦上弹奏二次，遇到这种情形，将指法的音弹在上方的弦上，就是要避免指法与旋律冲突。

Am 5fr. Em Fmaj7 3fr. F Fm C G C Am 5fr.

8 7 5 8 | 0 — 5 3 5 3 | 1 — 1 3 0 — 3 1 2 0 | 3 — 0 8 7 5 8

0 0 1 7 6 5 || 3 — 6 5 3 2 | 1 — — 1 2 3 · 3 2 1 6 5 | 2 3 3 1 7 6 5

Em Fmaj7 3fr. F Fm C G C C

— x — x — 5 3 5 3 | 1 — 1 3 0 — 3 1 2 0 | 3 — 0 8 7 5 8

3 — 6 5 3 2 | 1 — — 1 2 3 · 3 2 1 6 5 | 1 — 0 4 3 1 6 5 | 5 — — —



五、最后的弹奏可在强拍处加一些和声音，可以使音乐的感觉更加饱满。

Am 5fr. Em Fmaj7 3fr. F Fm C G C Am 5fr.

8 7 5 8 5 3 2 1 3 3 2 1 6 5 2 3 3 1 7 6 5

0 0 1 7 6 5 3 — 6 5 3 2 1 — 1 2 3 3 2 1 6 5 2 3 3 1 7 6 5

Em Fmaj7 3fr. F Fm C G C C

3 — 6 5 3 2 1 — 1 2 3 3 2 1 6 5 | 1 — 0 4 3 1<sup>b</sup> 6 5 — — —

六、也可以在一些音上做槌音、勾音或是滑音的效果，会让你的曲子更为优美。

以下这首“月亮代表我的心”我在某些音上做了滑音的效果，你可以弹弹看表情是不是更丰富了些呢？

C Em Fmaj7 3fr. G

0 0 0 0 5 || 1 3 5 1 7 3 5 5 6 7 1 6 5 — — 3 2

Am Am7/G Am7/G Am/F F G G+

1 1 1 3 2 1 1 1 2 3 2 1 6 3 2 — — —



# 爱情酿的酒

词/红蚂蚁 曲/红蚂蚁 演唱/红蚂蚁

Key G Play G Tempo 4/4 Rhythm Slow Soul Picking | x ↑ ↓ x ↑ ↑ ↓ ↓ |

G C G C

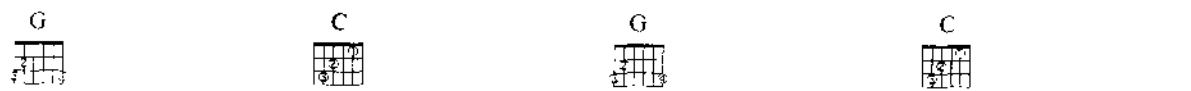
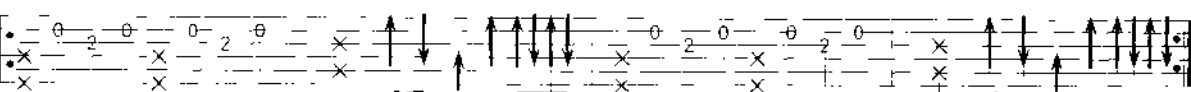
5 3 2 3 5 3 2 3 | i - - - | 5 3 2 3 5 3 2 3 | i - - - |

G C G C C Bm7

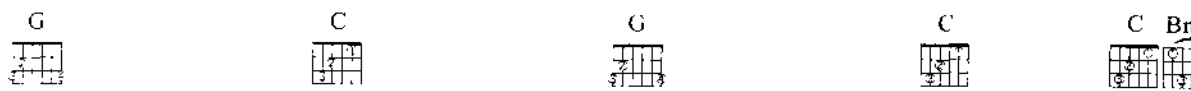

0 0 5 . 6 6 7 | i 6 6 . 6 4 . 3 | 4 3 . 3 - - - 3 - 0 6 i .

有人告 诉我 爱情 像 杯 酒 - - - 他还  
有人告 诉我 爱情 像 杯 酒 他说

Am7 D7



3 2 2 2 1 6 6 0 | 6 i . i 0 i i i | 6 . 5 5 - - - 5 - 0 0 :

告诉我 是杯 特 制 的 酒

喝它吧

C D7 G D7 G

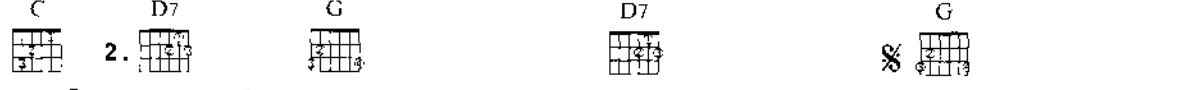

6 i . i - 2 1 | i - - - 0 0 0 | 3 5 . 5 5 5 5 . 5 5 . 6 5 i

别皱 眉 头 因为 它烫不了你的舌也

Em C D7 G

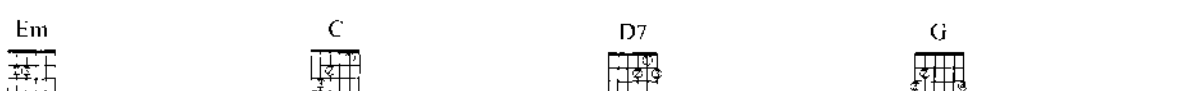

3 3 3 3 3 . 3 2 i . | 6 i . i 0 i 2 i | 3 5 3 2 - 3 5 . 5 5 5 5 . 5 5 . 6 5 i

烧不了 你的口 喝吧 别考虑 这么多 喔 它烫不了你的舌也

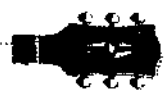

Em C D7

3 3 3 3 3 2 1 6 1 1 0 3 3 5 5 - - - 5 - - 0 5 |

烧不了 你的口 喝醉吧 不要回 头 喝

N.C. G C G

2 3 2 2 1 6 4 1 - - - 6 - - - 5 3 2 3 5 3 2 3 |

爱情 酿的 酒 (同前奏)

C C D7 G Em

6 - - - :| 6 1 1 - 2 1 1 - - - | 0 0 0 0 |

别皱 眉头 G.T. Solo 请自行发挥

C D7 G Em

0 0 0 0 0 0 0 0 | 0 0 0 0 0 0 0 0 |

C D7 Am7 C

0 0 0 0 0 0 0 0 :| 0 0 0 0 | 0 0 0 0 |

D7 D7

0 0 0 0 | 5 - - 3 5 :|

喔 因为 %

G C G C

1 3 2 3 5 3 2 3 6 - - - 5 3 2 3 5 3 2 3 | 6 - - -

酒 (同前奏)

Am7 C D7 D7

0 0 0 0 0 0 0 0 :| 0 0 0 0 | 0 0 0 0 |

G.T. Solo Fade Out

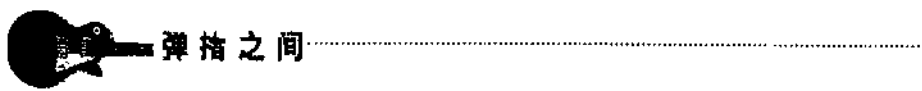

## 用心良苦

词/十一郎 曲/张宇 演唱/张宇

Key  $\sharp G$  Play  $G$  Capo 1 Tempo 4/4 Rhythm Slow Soul Picking | x  $\uparrow\downarrow$  xx  $\uparrow$ x | - -

G Am/ $\sharp F$  Em D

3 3 3 5 2 3 5 1 1 5 1 | 2 . 1 2 3 1 1 1 2 | 3 2 . 3 3 1 4 3 | 2 - - -

G Cadd9 G Cadd9 G C D G Cadd9

3 3 3 3 5 6 1 2 2 1 | 3 3 3 3 5 6 1 2 2 1 | 3 3 3 3 1 5 6 1 1 2 1 | 1 - - -

你的脸 有几分憔悴 你的眼 有残留的泪 你的唇 美丽中有 疲惫

G Cadd9 G Cadd9 G C D G F

3 3 3 3 5 6 1 2 2 1 | 3 3 3 3 5 6 1 2 2 1 | 3 3 3 3 5 6 1 1 2 1 | 1 - - 0 3 ||

























我用去 整夜的时间 想分辨 在你我之间 到底谁 会爱谁多 一点 我

Bm Em Bm Em Am7 Bm D C D

5 3 5 3 6 6 0 3 | 5 3 5 3 6 6 0 1 | 2 3 2 2 3 5 5 6 5 3 | 3 2 2 - 5 5 6 5 ||

宁愿 看着你 睡的如此沉静 胜过你醒 时决裂 般无情 你说



G 	Bm  2fr.	Em 	Bm  2fr.	Am7 	Bm7  2fr.	C 	D 
5 5 <u>6</u> 5	5 5 6	<u>1</u> <u>1</u> 6 5 3	<u>2</u> <u>2</u> <u>3</u>	2 2 <u>3</u> <u>2</u> 2	2 3	5 5 <u>5</u> <u>3</u> <u>3</u> <u>2</u> 2	5 5 <u>6</u> 5
你 想 要 逃 偏 偏		注 定 要 落 脚 情 灭		了 爱 熄 了 剩 下 空 心 要 不 要 春 已			
G 	Bm  2fr.	Em 	Bm  2fr.	Am7 	Bm7  2fr.	C 	D 
5 5 <u>6</u> 5	5 5 6	<u>1</u> <u>1</u> 6 5 3	<u>2</u> <u>2</u> <u>3</u>	2 2 3 5 5	2 3 6	<u>1</u> <u>1</u>	<u>1</u> <u>2</u> <u>1</u>
走 花 又 落 用 心		良 苦 却 成 空 我 的 痛 怎 么 形 容 一 生 爱				错 放 你 的	
G 	C 	D 	Am7 	Bm7  2fr.			
$\frac{4}{4}$ 1	5 .	<u>4</u> <u>3</u> <u>2</u> .	1	2	2	<u>2</u> <u>3</u> <u>5</u> 5	<u>2</u> <u>3</u> <u>6</u>
手	(我的)					痛 怎 么 形 容 一 生 爱	
C 	D 	G 					
1 1 1	<u>1</u> <u>2</u> <u>1</u>	1					
错 放	你 的	手	Fine				





# 好不好

电视剧“女儿当自强”主题曲

词/阿信 曲/阿信 演唱/五月天



D



C



2



4/4, = 70



Slow Soul

C Am7

0 0 0 0 0 0 0 0 | 1 5 1 2 4 3 2 2 3 | 1 5 1 2 4 3 2 2 3

(GT.Arp)

Fsus2 G C Am7

1 5 1 2 4 3 2 2 3 | 2 5 7 1 2 0 5 3 5 4 3 2 2 1 3 | 0 5 3 5 4 3 2 2 1 3 |

不知 是对或是 不对 不知 是好或是 不好

Fsus2 G C Am7

0 4 4 4 5 4 3 3 4 2 | 2 — — — 0 5 3 3 4 3 2 2 1 3 | 0 5 3 5 4 3 2 2 3 1 |

不知你 甘会笑 阮憨 热天 西北雨的 下午 想你 不知影你 在哪



Fsus2
G
Em
Am7

0 4 4 4 · 4 5 4 3 3 4 2 2 — — 3 4 ||: 5 5 5 7 6 3 | 5 4 3 4 6 6 · 5

真希望看到你的笑容 你的温暖充满着孤单的心脏 我  
 温暖充满着孤单的心脏 我

F
G
C
G/B
Am
Em

5 4 3 4 3 2 2 2 5 4 3 4 4 2 3 6 5 | 0 3 6 5 0 6 6 7 | 1 7 6 6 5 0 6 6 7

不能继续再等待 想要对你说 乎你想 乎你猜 是谁人 整眠烦恼 烦恼着  
 等待不能再继续 想要对你说 乎你想

F
Em
F
G
C
G/B
Am
Em

1 7 6 1 5 4 3 5 | 3 2 2 1 2 0 3 6 5 | 0 3 6 5 0 6 7 5 | 1 7 1 1 2 3 3 5

无情的风无情的雨 阻碍咱的路 甲你疼 甲你惜 甲你捧 在我双手中 我

F
Em
F
G
C
C
C

4 3 4 5 3 2 1 1 · 5 | 6 1 3 2 0 3 1 1 2 | 2 1 1 — — | 1 — 0 0

一生惟一的希望 要 给你快乐 好或不好

C
Am7
Fsus2
G

0 5 3 · 5 4 3 2 2 1 3 | 0 5 3 · 5 4 3 2 2 3 1 | 0 4 4 4 · 4 5 4 3 3 4 4 | 4 2 2 — —

日子有甜也有 艰苦 有你 有我互相 照顾 想要听你心内的 感想







# 龙卷风

词/周杰伦 曲/周杰伦 演唱/周杰伦



A



G



2



4/4 = 72



Slow Soul



1 5 3 1 4 3 1 2 3 2 | 1 5 3 1 4 3 1 2 3 2 | 1 5 3 1 4 3 1 2 3 2 | 1 5 3 1 4 3 1 2 3 2



1 5 3 1 4 3 1 2 3 2 | 1 5 3 1 4 3 1 2 3 2 | 1 5 3 1 4 3 1 2 3 2 | 1 5 3 1 4 3 1 2 3 2



5 2 2 1 3 | 5 2 2 1 3 | 6 3 3 2 4 | b6 3 4 3 2 1 b6 5

爱 像 一 阵 风 | 吹 完 它 就 走 | 这 样 的 节 奏 | 谁 都 无 可 奈 何



G Em7 Cmaj7 EDim7

5 2 2 1 3 5 2 2 1 3 6 3 3 2 4 6 3 4 3 2 1 5 6

没有你以后 我灵魂失控 黑云在降落 我被它拖着走静

Cmaj7 Bm7 Am7 D

6 3 3 1 1 5 1 5 5 2 2 7 7 5 7 1 0 6 1 6 1 6 1 1 2 3 3 2 2 3 4

静悄悄默默离开陷入了危险边缘 Ba-By 我的世界已狂风暴雨 呜

G Em7 Cmaj7 D

5 4 3 3 4 5 5 4 3 3 1 5 4 3 3 4 5 5 4 3 3 1 2 3 5 5 1 2 3 5 5 1 2 0 1 2 0 1 2 3 4 5 4 5

爱情来得太快就像龙卷风 离不开暴风圈来不及逃 我不能再想 我不能再想 我不能 我不我不能

G Em7 Cmaj7 D

5 4 3 3 4 5 5 4 3 3 1 5 4 3 3 4 5 5 4 3 3 1 2 3 5 5 1 2 3 5 5 1 2 0 1 2 0 1 2 3 4 5 i

爱情走得太快就像龙卷风 不能承受我已无处可躲 我不要再想 我不要再想 我不要 我不要再想你

G Em7 G/C G/D

1 5 3 1 4 3 1 2 3 2 1 5 3 1 4 3 1 2 3 2 1 5 3 1 4 3 1 2 3 2 1 5 3 1 4 3 1 2 3 2

不知不觉你已经离开我 不知不觉我跟了这节奏 后知后觉又过了一个秋 后知后觉我该好好生活

2.            

1 — — — — —     b2 b6 b2 b6 b2 b6 b2 b6     1 5 1 5 1 5 1 5     b2 b6 b2 b6 b2 b6 3 4

**(E.G solo)**

5 — — — — — 3 4 5     b7 b6     5 5 b6     5 — — — — — 3 4 5     b6 5 b6 5 b6 5 b6 5 4

**(Violin solo)**

1 5 3 1 4 3 1 2 3 2     1 5 3 1 4 3 1 2 3 2     1 5 3 1 4 3 1 2 3 2     1 5 3 1 4 3 1 2 3

不知不觉你已经离开我     不知不觉我跟了这节奏     后知后觉又过了一个秋     后知后觉该好好生活

1 5 3 1 4 3 1 2 3 2     1 5 3 1 4 3 1 2 3 2     1 5 3 1 4 3 1 2 3 2     1 5 3 1 4 3 1 2 3 2

不知不觉你已经离开我     不知不觉我跟了这节奏     后知后觉又过了一个秋     后知后觉我好好生活

1 5 3 1 4 3 1 2 3 2     1 5 3 1 4 3 1 2 3 2     1 5 3 1 1 5 3 1     1 — — — — —

不知不觉你已经离开我     不知不觉我跟了这节奏     后知后觉后知后觉

**Fine**  
**Rit.....**







G Am7 D Em Am7 Em

3 3 3 2 2 3 3 - 0 2 2 2 1 6 2 2 0 1 2 1 6 6 5 6 6 0 6 1 2 3 6 6 6 1 2 3 6 6 6 1

崎岖有平静 看着你的眼睛 我最熟悉的表情 一路上有你因为有了你人生  
如此的承担 面对岁月的河 对你已经无法割舍 我是爱着你深深爱着你一首

Am7 Bm7 Em G Em Bm

2 2 3 2 1 6 5 6 - - - 1 . 3 5 5 . 3 5 6 1 7 5 3 3 . 3 5

旅程不再冷 迎着风 迎向 远方的天空 路上  
属于我俩的清歌

Em Bm7 Am7 D Em G Em

6 1 7 5 . 3 2 1 2 3 . 2 2 3 5 2 2 - 0 1 1 6 1 1 6 6 6 5 5 5 1 . 1 -

也有艰难也有那解脱 都走得从容 因为你是我生命的所 有  
生命有了你我 已经无所求

Em Em Bm Am7 D G

1 6 5 6 3 3 2 1 2 3 . 2 3 5 6 1 1 - 2 4 1 -

将我的心放在你手中 陪你到永久

Em Bm Am7 D G Em Bm Am7 D G

1 6 5 6 3 3 2 1 2 3 . 2 3 5 6 1 1 - 1 6 5 6 . 3 2 1 2 3 . 2 3 5 6 1 1 -

将我的心放在你手中 陪你到永久 整个的心放在你手中 陪你到永久

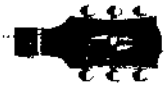



# 在凌晨

词/张震岳 曲/张震岳 演唱/张震岳



B



C



4/4 = 104



Slow Soul



各弦调降半音

C G/B Am Am7/G F Gsus4 C

|| 0 0 0 7 1 2 | 3 — 2 3 2 1 | 1 — — 2 1 6 | 1 2 1 6 | 1 2 1 1

G C G/B Am Am7/G F Gsus4 C

| 1 — — 1 2 3 — 2 3 2 1 | 1 — — 2 1 6 | 1 2 1 6 | 1 2 1 1

G C G/B Am Am7/G F G

| 1 — — — | 6 5 5 5 6 5 5 6 5 5 4 | 4 3 1 3 3 0 2 3 | 4 5 6 6 4 2 2 5 3

在凌晨 两点 十分 慌 张 想你 吸着 无法入 眠的 空气



C Dm7 G Em A Dm7 D7

3 — — — 4 3 4 4 5 5 5 — 6 5 5 5 4 3 3 0 3 3 4 5 4 4 — 3 2

如果是 梦境 也许是 幻影 我想 沉醉在 这里

G C G/B Am Am7/G F G

2 — — — 6 5 5 5 6 5 5 3 4 4 4 3 1 3 3 0 3 3 4 5 6 6 4 2 2 2 5 3

常常会 发现 你在我 的身旁 听我 当兵的故事 很有趣

C Dm7 G Em A Dm7

3 — — — 4 3 4 4 5 5 5 — 6 5 5 5 6 5 5 2 3 0 3 3 3 4 5 4 4 — 3 3 2

清晰的感觉 永远不会变 而你不在这里 陪我

G C G/B F G C G/B

2 — — — | 0 5 5 5 3 3 3 3 2 2 2 2 1 1 6 6 3 2 2 — 0 5 5 5 3 3 3 3 2 2 2 2 1

我忘不了你给我最当初的礼物 答应我陪我去寻找我的

F G Am Am7/G F D Dm7

1 6 6 5 5 — 0 5 5 5 3 3 3 3 3 0 3 2 1 3 2 2 1 6 6 1 7 1 4 4 3 3

梦想 到头来 我不是你 选择的人 也许你是 对的



G C G/B F G C G/B

2 — — — 05553333 22221 1 6 6 3 2 2 — 05553333 222211

忘不了你给我最当初的礼物 答应我陪我去寻找我的

F G Am Am7/G F D Dm7

1 6 6 5 5 — 05553333 0 3 2 1 3 2 2 1 6 6 1 7 1 4 4 6 5

梦想 到头来我不是你选择的人 也许你是对的

G C G/B Am Am7/G F G

5 — — — 6 5 5 5 6 5 5 6 5 5 4 4 3 1 3 3 0 2 3 4 5 6 6 4 2 2 5 3 1

在凌晨 两点 十分 慌张想你 吸着 无法入眠的 空气

C Dm7 G Em A Dm7 G

3 — — — 4 3 4 4 5 5 5 — 6 5 5 5 4 3 3 0 3 3 4 5 4 4 — 3 1

如果是 梦境 也许是 幻影 我想 沉醉在 这里

C C G/B Am Am7/G F G

1 — — 0 5 6 1 3 2 2 5 1 1 2 3 3 0 5 6 1 3 2 2 1 1 6 5



C Dm7 G Em A Dm7 D7

5 — — — 0 4 3 2 1 3 3 2 2 1 2 3 5 3 3 7 6 6 5 3 3 0 4 3 2 1 3 3 2 1 6 5

G C G/B Am Am7/G F G

5 — — — 0 5 6 1 3 2 2 5 1 1 2 3 3 0 5 6 1 3 2 2 1 1 6 5

C Dm7 G Em A Dm7

5 — — — 0 4 0 4 3 3 2 2 1 2 3 5 3 3 7 6 6 5 3 3 0 6 5 3 5 4 1 3 2 2

G Dm7 Dm7/G C

2 — — — :|| 4 5 4 4 — 3 1 1 — — — ||

沉醉在 这里

Fade Out

# Wonderful Tonight

Eric Clapton



G



G



4/4

Key

Play

Tempo

G D/F# C D

0 0 3 2 1 2 2 — 3 2 1 6 6 — 3 2 1 2 2 3 4 6

G D/F# C D

5 — 3 2 1 2 2 — 3 2 1 6 6 — 3 2 1 2 3 4 6 ||

G D/F# C D

5 0 5 5 3 4 3 2 2 5 5 — — | 0 0 5 5 3 4 3 3 2 2 2 2 — |

It's late in the eve-ning  
We go to a par-ty

She's wondering what clothes to wear  
And every one turns to see



G D#F C D

She puts on her make up  
This beautiful la - dy

And brushes her long long hair  
She's walking around with me

C D G D#F Em

And then she asks me  
And then she asks me

Do I look all right  
Do you feel all right

And I say  
And I say

C D G D#F

1. yes you look wonder- ful tonight  
yes I feel wonder- ful tonight

C D G D#F

2. I feel

C D G D#F Em

Wonderful be- cause I see the love lighting in your eyes  
Then the







6 6 6 6 2 5 5 — — 2 3 4 3 2 1 2 2 3 3 2 1 1 1

wonder of it all that you just don't re-a-lize how much I love



1 3 3 2 1 2 0 0 3 2 1 2 2 — 3 2 1 6 6 — 3 2 1 2

you



2 3 4 6 5 — 3 2 1 2 2 — 3 2 1 6 6 — 3 2 1



0 0 3 3 3 4 3 2 2 5 5 — — 0 5 4 4 4 3 3 1 2 — —

It's time to go home now And I've got an aching head



0 3 3 3 4 3 2 2 5 5 — — 0 5 4 4 3 1 2 — —

So I give her the car keys And she helps me to bed



C                      D                      G                      D#F                      Em

0 0 6 6 6 5 5 2 2 — — 0 3 3 3 5 5 1 1 — 0 1 2 3

And then I tell her As I turn out the right I say my

C                      D                      G                      D#F                      Em                      Em/D

4 4 4 4 4 3 2 2 2 3 2 1 5 1 1 — — — 0 0 0 2 2 3

darling you are wonderful tonight Oh my

C                      D                      G                      D#F

4 4 4 4 4 3 2 2 2 3 2 1 5 1 1 — 3 2 1 2 2 — 2 3 5 3 2

darling you are wonderful tonight

C                      D                      G                      D#F

2 1 6 1 — 6 6 5 6 5 — 3 2 1 2 2 — 3 2 1 6

C                      D                      G

6 — 3 2 1 | 2 3 4 6 | 5 — — —

Fine



# 原来你什么都不想要

词/郭裕康 曲/郭子 演唱/张惠妹



B → C

Key



G → A

Play



3

Capo



4/4, = 60

Tempo



Soul

Rhythm

Em G #Fm7 Em C Bm7

6 7 6 6 6 7 1 5 5 4 5 4 4 3 2 3 - 2 3 2 2 1 2 1 7 2 1 5 7 6

C D D Gadd9

3 1 0 0 2 4 2 0 5 4 3 3 2 3 2 1 2 - 5 - - 0 3 2 1 | 2 2 0 5 1 1 0 3 2 1

我知道 这样 不好 也知道

Em C D

2 2 2 2 5 6 5 1 1 1 1 1 6 5 6 6 i 0 i i i 1 1 1 1 3 2 2 - 0 3 2 1 |

你的爱只能 那么少 我只有 不停的 要 要到 你想 逃 泪湿的

Gadd9 Em C

2 2 2 5 2 2 1 0 3 2 1 2 2 2 1 3 5 5 6 i 6 6 6 5 i i 6 6 0 i i i 6 6 i |

枕头 晒干就 好 眼泪在 你的心里只是无理取闹 以为在 你身后 是我一辈子的







# 35 左右手的技巧【二】

## 打板

“打板”这种技巧，模仿了佛拉明歌(Flamenco)吉他演奏技巧中惯用的打板技巧，改编而成适合民谣吉他弹奏的一种技术，此种技巧经常搭配在Folk Rock或是Bossanova节奏型态中来使用，可使得节奏的强弱更加清楚。

弹奏时，利用右手击弦后下压的力量，使用手指(图一)与俗称手刀部位(图二)将弦击往指板处，除了将此弦制音外，并发出击板的声音。在指板之最末端与音孔交接处，可以得到比较大声的打板声响。正因为如此，所以再演奏时，节奏必须鲜明而有力量，节奏动线也必须非常清楚。打板在歌曲中，一般都是以伴奏为主，有时也会搭配另一把吉他来做插音或是即兴的Solo，都是常常可以听到的。

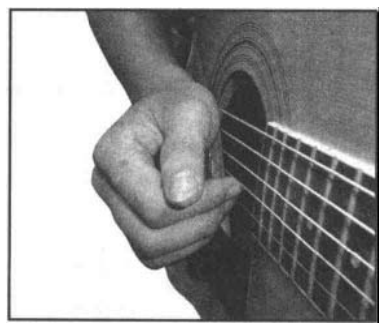

图一

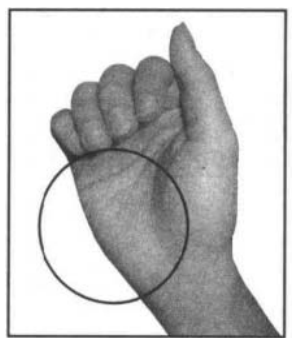

图二

在乐谱里中使用框框来表示此种技巧

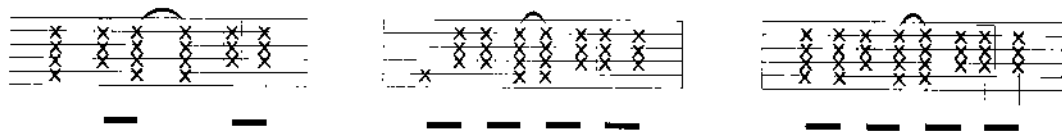

# 写一首歌

词/顾子曲/顾子演唱/顾子



Key  $\flat E$  Play C Capo 3 Tempo  $4/4 \text{ } \downarrow = 134$  Rhythm Soul

Cadd9 Cadd9 Amadd9 Amadd9

0 0 0 0 2 · 7 7 1 1 0 0 0 0

呜.....

Dm9 Dm9 Gsus4 G

1 · 6 4 4 4 5 5 — — · 6 5 — — 0 — — —

呜.....

Cadd9 Cadd9 Amadd9 Amadd9

5 4 3 3 4 4 5 5 4 3 3 3 3 — 7 6 7 7 1 1 3 3 — 0

月亮在你的眼睛 太阳在我心



Dm9 Dm9 Gsus4 G

0 x x x x x x x | 0 x x x x x x x | x x x x x x x x | x x x x x x x x |

6 4 3 3 2 2 2 | 2 3 2 2 4 4 - | 1 7 1 1 2 2 5 | 5 - 0 5 5

现在我唱这首歌 oh 只为你 想把

Cadd9 Cadd9 Amadd9 Amadd9

x x x x x x x x | x x x x x x x x | 0 2 0 1 0 0 | 0 x x x x x x x |

5 4 3 3 4 4 5 | 5 4 3 3 3 3 - | 7 6 7 7 1 1 3 | 3 - 0 0 3

所有烦恼都忘掉 做不做到 你

Dm9 Dm9 Gsus4 G

0 x x x x x x x | 0 x x x x x x x | x x x x x x x x | x x x x x x x x |

6 6 6 5 4 4 4 3 2 | 2 2 2 4 4 - | 1 2 2 5 5 - | 1 2 2 5 5 4

明白我心在燃烧 因为你 因为你 .....

Cadd9 Cadd9 Amadd9 Amadd9

x x x x x x x x | x x x x x x x x | 0 2 0 1 0 0 | 0 x x x x x x x |

3 - - - | 0 0 0 5 5 4 | 3 - - - | 0 0 0 6 6 |

..... on ..... 为

Dm9 Dm9 Gsus4 G

0 x x x x x x x | 0 x x x x x x x | x x x x x x x x | x x x x x x x x |

3 4 4 - | 4 - 0 0 | 0 0 0 0 | 0 0 0 0 3

你..... 你





Cadd9 Cadd9

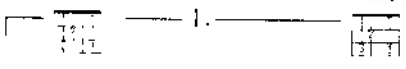

1.

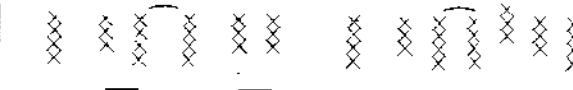

2 2 2 2 1 1 1 2 2 2 1 3 3 -

心中的话 我全 都想听

Amadd9 Amadd9

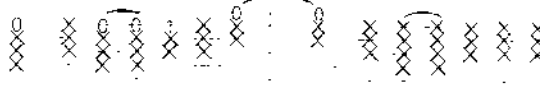
7 6 7 7 1 1 3 3 - 0 0

能不能 相信

Dm9 Dm9

3 3 2 3 3 2 2 3 3 3 2 2 3 3 4 4

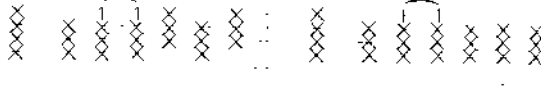
所有的梦 里全 都是你

Gsus4 G

1 7 1 1 2 2 2 2 - 0 0

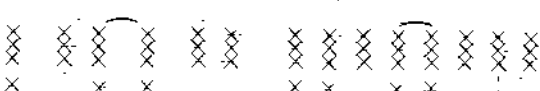
会不会 停息

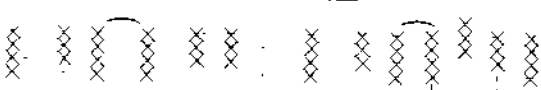

Cadd9 Cadd9

3 3 3 3 3 2 2 1 2 2 1 2 2 3 3

和你一起 是否 不会再放 弃

Amadd9 Amadd9

7 6 7 7 1 1 3 3 2 1 7 7 1 1

你 的心 里有 没有秘 密

Dm9 Dm9

3 2 3 3 2 2 3 3 3 2 2 3 3 4 4

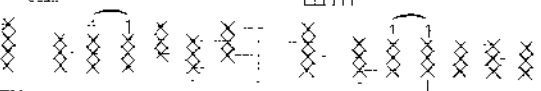
我 分不 清不 要在 意

Gsus4 G

1 1 7 7 1 1 2 2 2 2 2 2 2 1 1 2 2 1

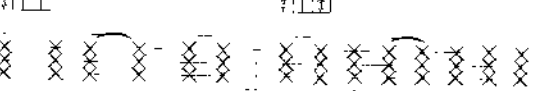
只 想 为 想 为 你 写 一 首

Cadd9 Cadd9

1 3 3 - - 0 0 0 1

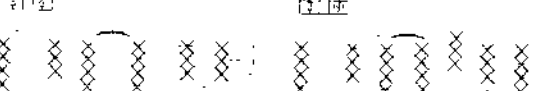
歌 写

Amadd9 Amadd9

2 3 3 3 - 3 - 0 1

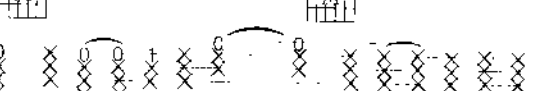
一 首歌 - 一首 歌 都



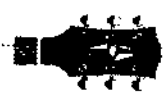

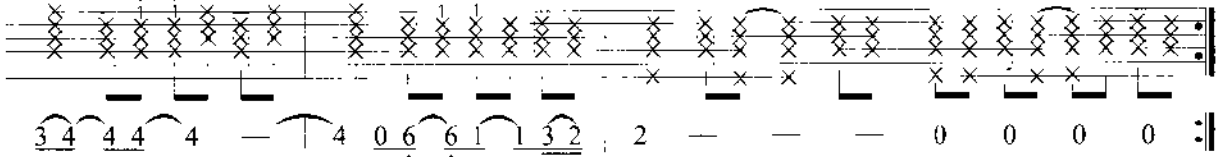

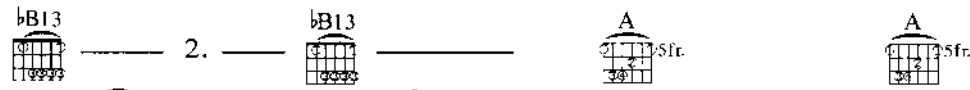
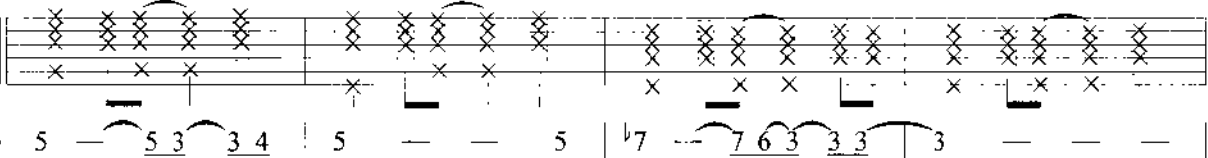
  
 3 4 4 4 4 — 4 0 6 6 1 3 2 | 2 — — — 0 0 0 0 :||

是你 呜.....

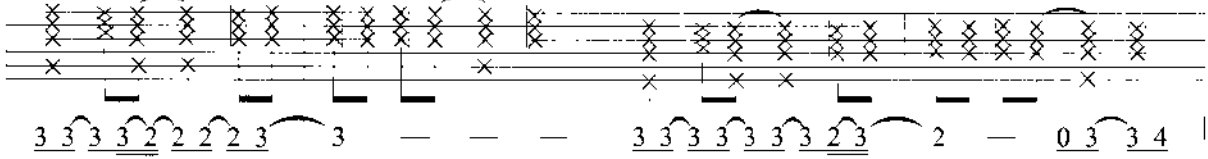

  
 5 — 5 3 3 4 | 5 — — 5 | b7 — 7 6 3 3 3 | 3 — — — |

Love's in the air it's e - very - where

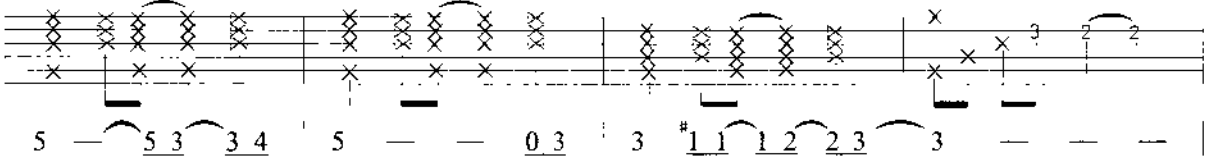

  
 3 3 3 3 2 2 2 3 3 — — — 3 3 3 3 3 3 2 3 | 2 — — 0 3 3 4 |

Every one can see Every one can feel that

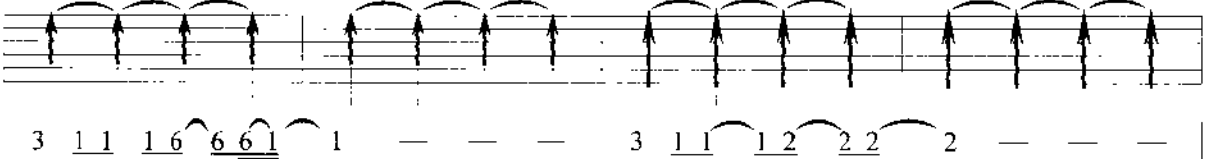

  
 5 — 5 3 3 4 | 5 — — 0 3 | 3 #1 1 1 2 2 3 | 3 — — — |

Love's in the air It's doesn't matter where

  

  
 3 1 1 1 6 6 1 | 1 — — — 3 1 1 1 2 2 2 | 2 — — — |

Every one a gress Love's is all we need



节省谱面后段歌词请自行参考

Where the moon falls in your eyes.  
 I know the sun has set.  
 The fire still burn with in me.  
 Since the day we met.  
 I know my heaven would be so complete.  
 You could make it real.  
 I won't let this chance go by.  
 I can see. I can feel.  
 You and the moon falls in you eyes.  
 I know the sun has set.  
 The fire still burns with in me, with in me.  
 Dream On Di Down , Dream On Di Down.



# More Than Words

N.Bettencourt & G.Cherone



$\flat G$



G



4/4



R.H. 为点弦技巧



各弦调降半音

Chord diagrams and fretboard notation for the first line of the piece. Chords: G, Cadd9, Am7, Am7, C, D, Dsus4, G.

Chord diagrams and fretboard notation for the second line of the piece. Chords: Cadd9, Am7, Am7, C, D, Dsus4, G.

Chord diagrams and fretboard notation for the third line of the piece. Chords: Cadd9, Am7, Am7, C, D, Dsus4, G.

Say - ing I love you It's not the words I want to hear from you  
 Now that I've tried to Take to you And make you under -



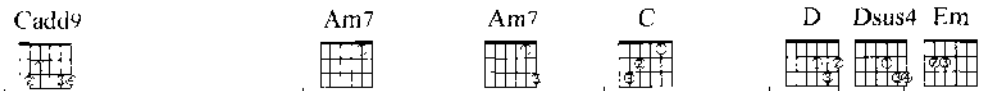

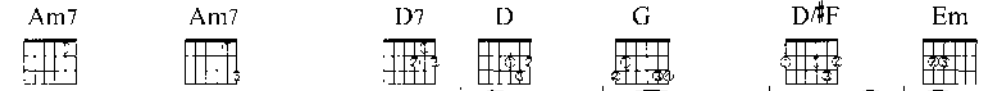
  
 5 3 3 5 5 3 6 5 5 — 5 6 5 5 5 5 5 5 6 6 5 5 4 3 3
   
 It's not that I want you not to say But if you on - ly know
   
 stand All you have to do is close your eyes And just reach out your hands

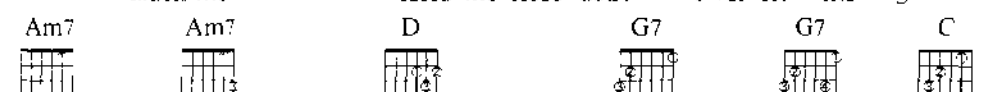

  
 3 — 3 — 4 4 3 2 — 5 6 5 5 4 3 3 3 3 3 3 5 5 7
   
 How and ca - sy It would be to show me how you feel
   
 and touch-me touch-me Hold me close don't e-ver let me go



  
 1 — 6 6 6 6 6 — 4 0 4 7 7 6 6 7 1 b7 b7 b7 b7 b7 1 b7 b7
   
 More than words More than words Is all you have to do to make it real
   
 Is all I e-ver Need - ed you to show

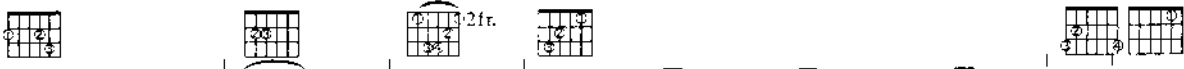
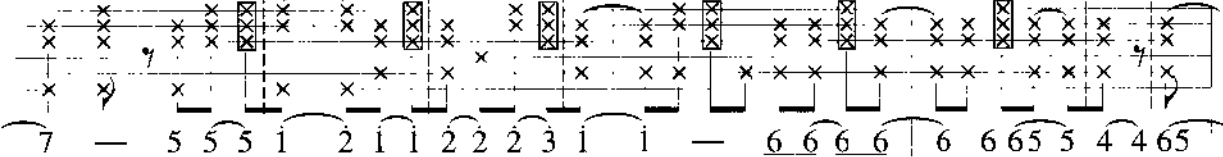

  
 6 — 5 4 4 1 1 5 5 b5 b5 4 4 4 5 4 3 3 3 3 5 5 6 6 — 0 6
   
 Then you wouldn't have to say that you love me

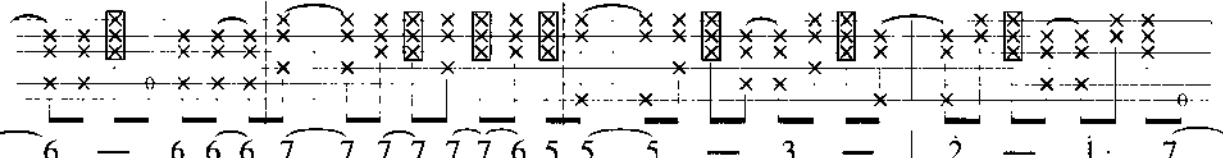

  
 6 — 4 — 7 — 5 — 3 — 3 — 2 — 1 7
   
 'Cause I'd al - rea - dy know what would you do

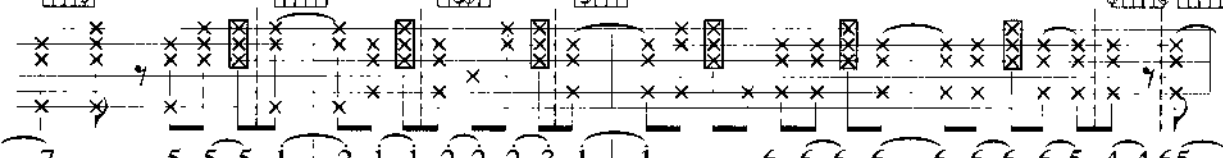

D9#F Em Bm C G Am7  
  
  
 7 — 5 5 5 1 2 1 1 2 2 2 3 1 1 — 6 6 6 6 6 6 6 5 4 4 6 5  
 If my heart was tom in two More than words to show you feel

D7 G  
  
  
 6 — 6 6 6 7 7 7 7 7 6 5 5 5 — 3 — | 2 — 1 7  
 that your love for me is real what would you say

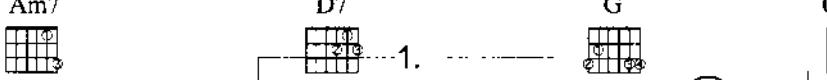
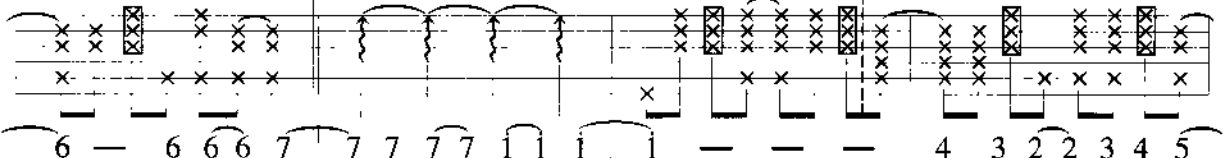
D9#F Em Bm C G Am7  
  
  
 7 — 5 5 5 1 2 1 1 2 2 2 3 1 1 — 6 6 6 6 6 6 6 5 4 4 6 5  
 If I took those words a - way Then you could—n't make things new

Am7 D7 G Cadd9  
  
  
 6 — 6 6 6 7 7 7 7 1 1 1 — — — 4 3 2 2 3 4 5  
 Just by say - ing I love you Da di da da di da

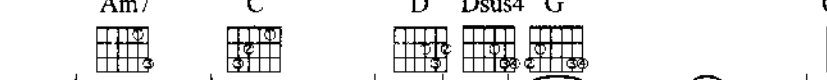
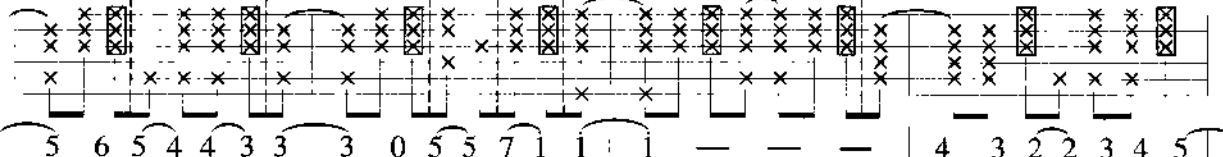
Am7 C D Dsus4 G Cadd9  
  
  
 5 6 5 4 4 3 3 3 0 5 5 7 1 1 1 — — — 4 3 2 2 3 4 5  
 more than words Da di da da di da

Am7 D7 D7 G Cadd9

5 — — — 0 0 0 0 : 7 7 7 7 7 1 0 1 — —

-ing I love you

Am7 Am7 C D Dsus4 G Cadd9

4 3 2 2 3 4 4 5 6 5 4 4 3 3 3 0 5 5 7 1 1 1 — — —

Da di da da di da di da da da More than words

Am7 Am7 C D Dsus4 G Cadd9

4 3 2 2 3 4 4 5 6 5 4 4 3 3 3 0 5 5 7 1 1 1 — — —

Da di da da di da di da da da More than words

Am7 D7 C D Dsus4 G Cadd9

4 3 2 2 3 4 5 5 0 5 4 4 3 4 4 3 5 7 1 1 1 — — —

La li da da da da da da da More then words

Am7 Am7 C D G

4 3 2 2 3 4 5 5 — 0 0 4 4 4 3 5 7 1 1 1 — — —

La di da da da da da La La More then words



Free Tempo

More than

words

Fine





# 星晴

词/周杰伦 曲/周杰伦 演唱/周杰伦



G



G



4/4 = 88



R &amp; B

G Cadd9

0 1 1 5 5 1 1 5 0 1 1 5 5 1 1 5

(一步两步三步四步望着天上牵手)

Em7 Cadd9

0 1 1 5 5 1 1 5 0 1 1 5 5 1 1 5

一颗两颗三颗四颗连成线看星)

G Cadd9

0 1 1 5 5 1 1 5 0 1 1 5 5 1 1 5

(一步两步三步四步望着天上牵手)

Em7 Cadd9

0 1 1 5 5 1 1 5 0 1 1 5 5 —

一颗两颗三颗四颗连成线看星)

G G/F

0 3 3 3 2 1 2 5 6 6 7 7

乘着风 游荡 在 蓝天 边

Em7 D

0 1 1 1 7 6 7 1 2 2 3 2 1 6 5

一片云 掉落 在我面 前



Cadd9



G/B



Am7



D



0 4 4 4 3 3 2 | 0 3 3 3 2 1 | 1 6 1 6 1 2 1 2 | 2 3 3 5 4 3 2

捏成你的形状 随风跟着我 一口一口吃掉忧愁 呼呼

G



G#F



Em7



D



1 3 3 3 2 1 | 2 5 6 5 5 5 6 | 0 1 1 1 7 6 | 7 3 4 4 3 2 1

呼载着你 仿佛载着阳光 而不管到哪里 都是晴天

Cadd9



G/B



Am7



Dsus4



0 6 4 4 4 3 2 1 | 0 3 3 3 2 1 | 1 6 1 6 1 2 1 2 | 2 3 3 0 3 2 2

而蝴蝶自在飞 花也布满天 一朵一柔因你而香 试图

Cadd9



D/C



Bmsus4



2fr.

E



1 2 2 3 3 6 6 7 | 7 2 2 7 6 | 7 5 5 6 6 7 6 | 6 6 5 5 5 4

让夕阳飞翔 带领你我环绕大自然

Am



Ammaj7



Am7



D



4 — 0 3 4 4 | 4 — 0 2 3 4 | 4 5 5 6 6 1 1 3 | 2 — 0 5 5 5

迎着风 开始共渡每一天 手牵手



 <b>G</b>	 <b>Bm7</b>	 <b>Em7</b>	 <b>D</b>
 x	 x	 x	 x
5 1 1 2 2 3 3 4	4 5 5 0 5 6 7	7 1 1 7 7 6 6 5	3 4 5 0 6 7 1
一步 两步 三步 四步	望着天 看星星	一颗 两颗 三颗 四颗	连成线 背对背

 <b>Cadd9</b>	 <b>G/B</b>	 <b>Am7</b>	 <b>Dsus4</b>
 x	 x	 x	 x
1 1 1 1 7 6 5	5 0 5 5 4 3 4	4 5 5 6 4 2	2 0 5 5 5
默默许下心愿	看远方的星	是否听 的见	手牵手

 <b>G</b>	 <b>Bm7</b>	 <b>Em7</b>	 <b>D</b>
 x	 x	 x	 x
5 1 1 2 2 3 3 4	4 5 5 0 5 6 7	7 1 1 7 7 6 6 5	3 4 5 0 6 7 1
一步 两步 三步 四步	望着天 看星星	一颗 两颗 三颗 四颗	连成线 背对背

 <b>Cadd9</b>	 <b>G/B</b>	 <b>Am7</b>	 <b>Dsus4</b>
 x	 x	 x	 x
1 1 1 1 7 6 5	5 0 5 5 2 7 1	1 1 2 3 4 2	2 0 5 4 3 2 1
默默许下心愿	看远方的星	如果听 得见	它一定实现

 <b>Cadd9</b>	 <b>D/C</b>	 <b>Bm7</b>	 <b>bD/bB</b>
 x	 x	 x	 x
5 1 1 0 1	0 7 0 7 7 6 7 5	0 7 0 7 7	0 b6 0 b6 b6



Am Ammaj7 Am7 Dadd9

0 6 0 6 6 — 0 6 0 6 6 — 0 6 0 6 6 — — 7 6 5 4 :||

呼 呼

G F9 Em G

1 1 1 7 1 4 1 6 1 4 3 1 — — —

Fine



### 手指练习

3 2 1 2 1 3 1 3 1 4 2 1 4 2 1 4 3 2 1 2 1 3 1 3 1 4 2 1 4 2 1 4  
 14 13 12 13 12 15 12 15 13 17 15 13 17 15 13 16 14 13 12 13 12 15 12 15 13 17 15 13 17 15 13 16

注：1 2 3 4 表手指代号。可依次选择任意琴格来作练习。



# 36 音感的培养

## Guitar

音感的培养对于一个学习音乐的人来说是相当重要的。或许在你的朋友当中有相当多的人有不错的乐器基础，在听到任何旋律时，都有能力利用自己所擅长的乐器把它弹出来，但是一旦手上没有乐器，就搞不清楚旋律的音阶进行是哪些音了；或者是知道把它演奏出来，却不知道如何利用简谱把旋律记录下来；又或者您是喜欢创作，偶而写写歌的人，有时灵感一来，突然哼出一段十分优美的旋律，恰巧手边又没乐器，这时如果你又不知道如何将脑海里的音符记录下来，结果往往过不了几分钟，就忘得一干二净了。这些经验你一定碰过，因此音感训练将是进阶班的琴友们不可或缺的一项技术。

### 一、唱谱

笔者认为唱谱是培养相对音感最有效的方法了。嘴巴其实也是一种乐器，常常唱谱，会让您对于音程的感觉更加敏锐。首先，建议各位先从自己熟悉的曲子练起，像是「小蜜蜂」、「太湖船」、「小星星」……等简单又熟悉的曲子，找到它们的简谱，大声的唱出来，并将之背熟，练到不需看谱也能唱得出来，或者是可以默写出来，（默写还可以训练写谱的能力），然后一首接一首的练习。

### 二、增加谱的难度

上例的童歌，音程都不会太广，如果您都练会了，就可以选择流行歌来做练习，练习时请注意一点，流行歌曲的转音特别多，各位在练习时可以省略那些音。另外一点是要特别注意半音的训练及大音程（二个八度音以上）的练习。

### 三、反覆练习

以上的练习，对于一个进阶班的琴友们特别重要，一定要做到每天抽空不停地反覆练习。笔者估计不到一个月的时间，您便能开始推敲出歌曲的旋律，甚至于心里想的旋律也都可以自己写下来，这也是为什么有些人写歌是不需要乐器，随时随地都可以创作的原因了。



# 37 节奏感的训练

## Guitar

旋律、节奏与和声可以说是音乐构成的三大要素，其中，节奏这一环似乎常常为初学者所忽略。笔者曾在许多歌唱比赛的场合中，听过许多音色非常了得、但是却始终与伴奏的拍子轧不起来的人；也看过有些人吉他弹得非常好，只是速度忽快忽慢，而且自己并没有发觉到。像这样一个人独奏也就罢了，若是与别人合奏时，往往会因为一个人的拍子不稳而使其他的成员也乱了阵脚，甚至被迫中断，乱成一团。

以下是简单的拍子练习，请准备节拍器，以脚跟着踩拍子，一拍踩一下。练习时还要一边唱拍子，谱上写「1」就念「哒」，速度不宜太快或太慢，初学者以每分钟60拍开始练习最为恰当。练习时不要贪快，务求把拍子练稳。不要看这些练习简单，其实它们都需要经年累月的练习，才能有所成果的。

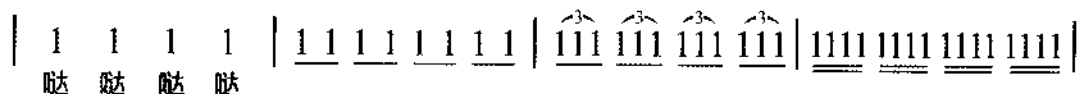

接下来是混合了休止符的练习，记「1」的地方念「哒」、记「0」的地方念「嗯」。等练熟以后，「0」的地方就不必念出来。

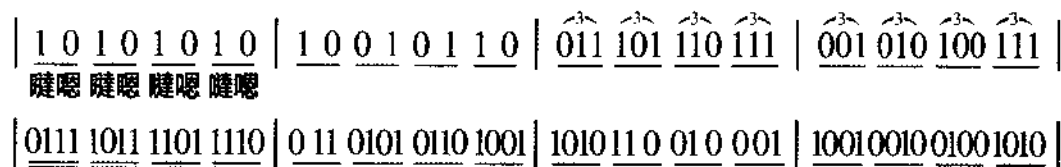

最后是拍子混合练习，大家可以自己任意组合练习，例如：

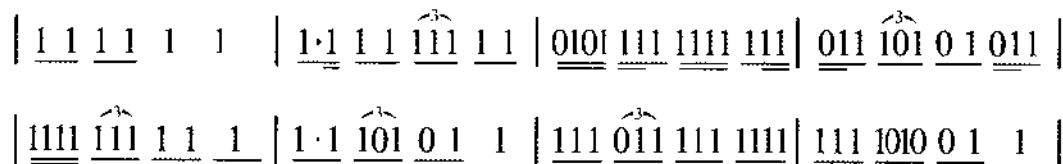

遇到像上面比较复杂的练习，我们可以先将每一小节反覆练熟，甚至每一拍反覆练习，等练熟些以后再慢慢把它们串联起来。



# 38 漫谈抓歌技巧

## Guitar

提起「抓歌」这个名词，让笔者回想起以前学吉他时听 Brother Four、Bread、Simon & Garfunkel.....的那个时代。以前的谱不像现在那么齐全，经常听到一首好歌，在苦苦寻找那些歌谱而不得时，总感到非常地懊恼。我想这种现象会发生在每个学吉他的人身上。但想要自己来抓歌，却又如同遇到瓶颈一般，常有人望而怯步。

其实不必如此，抓歌基本上是一种极为公式化的学习方法，因为我们扮演的角色即是在复制歌曲，抄袭总是比创作来得简单，而任何创作总是从抄袭开始学的。所以笔者希望大家在学习抓歌的同时能培养创作的能力，因为学习歌曲中的技巧做为激发编歌时的灵感来源才更重要的。

### 一、旋律：

旋律是决定一首歌「调性」的重要关键。提到调性又难免要提到大家会觉得有些恐惧的名词「音感训练」。不过还好，对于弹过吉他的人而言，对于大调单音的高低应该都能分辨出来，在这里我们要提的是一种相对音感的训练。

相对音感简单的说就是我们听到一首歌的旋律时，能够唱出旋律在此调的音程分布，也就是能听出此调之 Do、Re、Mi 的音高，我们称它叫相对音感。至于相对音感的训练，我们可以在弹奏歌曲时，多多练习唱谱，也就是唱该调之 Do、Re、Mi、Fa、Sol、La、Si、Do，试着去体会音高之间的相差程度，这是一个比较正确的学习方法。不过如果你还没有这种能力，你也可以用你学过的音阶型態，尝试去找出主音的位置，也就是 Do 音。主音找出后，这首歌的调子也就差不多呼之欲出了。

在我们决定了歌曲的调性之后，我们可以使用移调夹（Capo）移到我们好弹的调子上，但是如果这首歌是用吉他伴奏的，我们必须听出它是使用什么调子的和弦弹的，因为每个和弦的音响效果不一样。譬如说，以移调夹（Capo）夹第 4 格，用 C 大调和弦弹之，可以得到 E 大调之歌曲，



与直接弹开放之 E 大调和弦虽属同样之和弦，但因弹奏时音高与音的排列顺序不一样，所以弹奏时的效果自然不同。这一个观念在编曲上非常重要，道理是一样，巧妙各有不同。我们可以听歌曲使用之指法，与指法上音的排列顺序，来判断我们应该使用何种调子来弹奏。

## 二、和声：

和声在这里简单地说，指的就是和弦。在我们决定了歌曲的调性之后，接下来便是关系歌曲结构的重要工作——抓和弦。

- (1) 如果你的功力较弱，不妨可以分两次抓。先把主要之三和弦抓出来，一面放录音带，一面试试和弦的感觉，因为你的调子已和录音带上一样，所以和弦感觉很容易能抓出来，或者可以听听根音 (Root) 或贝斯音 (Bass) 的进行，因为录音机上之低音总是比较明显，再把它逐一记下来，这时你可能要准备一台耐用的录音机，因为很你反覆不停地操作可能会减低它的寿命，但是这是绝对值得的！

第二次听的时候，便可抓一些于和弦之转位、和弦之外音……等和弦。基本上和弦之根音必落在和弦之主音上，但有些歌曲在编曲时考虑对位与根音的连接，会使用转位和弦，如 C/B、Am/G、Dm7/G……等和弦，都要一一把它抓出来。另外在和弦配置上，也可能使用和弦外音，如 Csus4、Am6、C9、Gaug (增和弦)、#Fdim (减和弦) 等，以美化和弦。诸如此类之和弦，如果仔细听，再加上音感之辅助，不难听出。

- (2) 如果你已有稍许的功力，不妨也来做一番革命，这里所谓的革命即是创造的意思。除了要把抓出来的东西，很清楚地纪录在谱上以外，还需加以创造和弦。你可以使用代用和弦来增加和弦内涵，也可以使用经过音来连接和弦。但是这首歌如果是吉他单独伴奏，为避免别人诟病，我们还是必须老老实实地将每个小节抓正确才好。





### 三、节奏

通常在一首歌曲里，为了能够维持歌曲原有的风貌，加入适当的节奏便成了重要的工作。节奏形态有很多种，如Waltz（华尔兹）、Soul（灵魂乐）、Folk Rock（民谣摇滚）、Rumba（伦巴）……等，都是我们必须研究的。在现在的流行歌曲里，我们很容易把歌曲分成A（主歌）、B（副歌）之曲式，通常在A段我们习惯用指法来弹奏，B段就使用节奏来表现，这样的伴奏方式能够让歌曲有高低的变化，唱歌的时候Feeling会比较好些。但是有些节奏感比较强的歌，有可能从头到尾使用刷Chords的方式，通常这些歌的刷Chords方式，会依照歌曲的节奏型态而经过设计，譬如在李宗盛—我有话要说：灰狼LOBO……等专辑里。都可学到很多刷Chords的技巧

至于指法方面，李宗盛—生命中的精灵、蔡蓝钦—这个世界、Jim Croce（吉姆克罗斯）、Don McLean（唐·麦克林）、Simon & Garfunkel（赛门与葛芬柯）、Joan Baez（琼拜丝）、John Denver（约翰丹佛）、Dan Fogelberg（丹·佛格柏）…等都是不可不学的精典名作。总之，一首好的歌曲除了要有优美的旋律、丰富的和声之外，更重要的是要配上适当的节奏。

### 四、编曲

在现在的流行歌曲中，因为电脑音乐的普及，以及大家广泛的使用MIDI编曲，歌曲几乎都不再是单纯的吉他伴奏了，这也就是我们要重新编曲的原因。

当我们要抓的歌其前奏、间奏使用的乐器不是吉他，而是管乐器或是弦乐器，可以利用他们乐器的特性，适当的加入吉他的技巧，如Hammer-on（槌音）、Pull-off（勾音）、Slide-on（滑音）……等等。而许多歌曲的Solo（主奏）或即与演奏（Ad-Lib）部分速度很快，而旋律部份又紧凑而重要，所以通常单支吉他无法完整的表现。这时我们可考虑编成双吉他，乃至三吉他来表现。



再者，要告诉大家，抓歌是一种经验的累积，从抓歌的过程中可以学到旋律的起伏变化、和声的编写、指法的运用、刷 Chord 的技术...等技巧。抓过的歌越多，得到的也就越多，在歌曲的运用上，自然多一种变化，功力也因此日渐提升。

如果你还徘徊在抓歌的十字街头，希望在读过本文之后，能有个比较清楚的学习观念。我想，多抓歌、多听歌、多写、多创作，绝对是学好任何一种乐器的不二法门。



# 39 简化和弦

学到这里，相信你应该已经搞清楚封闭和弦的推算方式了，还是已经被整惨了。没关系，这章里我们来看看除了大封闭式的和弦压法外，还有怎样的方法可以简化它。

如果有一首歌曲的速度很快，而且必须弹奏出像分散和弦或是16Beat的节奏效果，那你就必须将和弦简化，否则全部都用大封闭来弹那是会死人的。使用简化和弦必须特别注意根音的问题，很多和弦经过简化过后所弹的根音并非原和弦的根音，所以通常会把根音交给另外一个演奏者（或是Bass手）来弹奏，不过如果是节奏就没这个问题了。另外，在双吉他的演奏也常常出现这种「简化和弦」来搭配演奏。

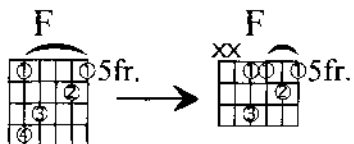
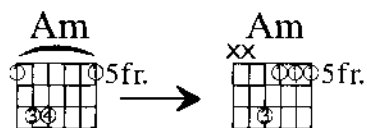
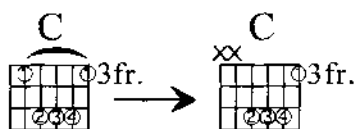
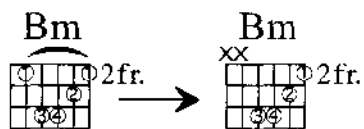
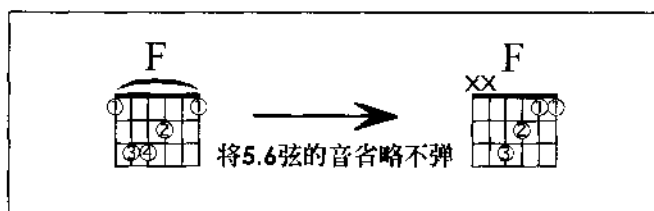

▶ 范例一

Am G F G Am G F G Am

The diagram shows a sequence of guitar chords: Am (5fr), G (3fr), F (3fr), G (3fr), Am (5fr), G (3fr), F (3fr), G (3fr), and Am (5fr). Below the chords is a fretboard diagram with notes marked with 'x' and a rhythmic pattern of eighth notes.

▶ 范例二

C Em F G C

The diagram shows a sequence of guitar chords: C (8fr), Em (7fr), F (5fr), G (7fr), and C (8fr). Below the chords is a fretboard diagram with notes marked with 'x' and a rhythmic pattern of eighth notes.



# Lemon Tree

词/许常德 曲/Hinkel Fredent Haler 演唱/苏慧伦



Am



Am



4/4 = 138



Trot

Am 	Em 	Am 	Em 
X X X X X X	X X X X X X	X X X X X X	X X X X X X
6 0 6 0	3 0 3 0	6 0 6 0	3 0 3 0

Dm 	Em 	Am 	Am 
X X X X X X	X X X X X X	X X X X X X	X X X X X X
2 0 2 0	3 0 3 0	6 0 3 5	6 0 0 3

Am 	Em 	Am 	Em 
X X X X X X	X X X X X X	X X X X X X	X X X X X X
3 3 3 6 6 6	2 2 5 5	3 3 3 3 2 2 1	2 2 3 3
个人孤单单	的爱下午	当风吹得每棵树都想跳舞	爱上了云 爱 上你 多么希望像你自由 来去



Am Em Dm Em

3 · 3 3 · 3 6 · 6 6 | 2 · 2 2 · 5 5 - | 3 · 3 3 · 3 3 · 2 2 · 1 | 2 2 · 3 3 · 5 5 · 3 |

记得昨天你穿蓝色衣服你说对爱太专注容易孤独这句  
原来星期天容易思念反覆看着电影一遍一遍孤独

Dm Em Am Am

3 · 2 2 · 1 2 · 3 3 | 0 0 · 2 3 · 2 2 · 1 6 - - - | 0 0 0 0 · 3 :|

话什么意思我不清楚我  
独的流着眼泪回忆太美爱

C G Am Em

3 4 · 5 5 0 · 3 5 6 · 2 2 - | 1 · 1 1 · 1 1 · 1 1 · 2 | 3 · 3 5 · 3 3 5 · 5 |

多美丽充满香气只是在心里它总是酸溜溜地我不

F G C G

5 4 · 4 4 3 3 2 | 2 0 2 · 2 2 · 1 | 2 · 3 3 · 3 3 - 0 0 0 0 5 |

懂我自己越来越像Lemon Tree我

C G Am Em

3 · 3 4 · 5 5 - | 5 · 6 6 · 2 2 0 5 | 1 · 1 1 · 1 1 · 1 1 · 2 | 3 · 5 5 · 3 3 5 · 5 |

一天一天更爱你我不管不管不管爱会苦苦地海蓝





G C E

0 2 - 3 2 3 2 2 · 2 2 0 1 1 2 1 | 0 · 2 3 · 2 3 · 2 3

1 so - la - tion 期 待 下 雨 的 一 棵 Lemon Tree

Am Em Am Em

3 · 3 3 · 6 6 · 6 6 2 · 2 2 · 5 5 - 3 · 3 3 · 3 3 · 2 1 · 1 2 2 · 3 3 · 5 5 · 3

你 总 是 望 着 蓝 蓝 海 面 说 着 流 浪 过 的 梦 容 易 实 现 这 句

Dm Em Am Am

3 · 2 2 · 1 2 3 | 0 0 0 · 2 3 · 2 2 · 1 6 - - - | 0 0 0 0 · 5

话 什 么 意 思 我 不 清 楚 爱

C G Am Em

3 4 · 5 5 0 · 3 | 5 6 · 2 2 - 1 · 1 1 · 1 1 · 1 1 · 2 3 · 3 5 · 3 3 5 · 5

多 美 丽 充 满 香 气 只 是 在 心 里 它 总 是 酸 溜 溜 地 我 不

F G C G

5 4 · 4 4 3 3 2 2 0 2 · 2 2 · 1 2 · 3 3 · 3 3 - | 0 0 0 0 · 5

懂 我 自 己 越 来 越 像 Lemon Tree 我





C G Am Em

3 3 4 5 5 - 5 6 6 2 2 0 5 1 1 1 1 1 1 2 3 5 5 3 3 5 5

一天一天 更爱你 我 不管不管不管爱会 苦苦地 海蓝

F #Fdim7 G

5 4 4 4 2 3 2 2 0 2 2 2 1 3 1 1 2 2 5 6 5 6 6 5 5 6 6 5 5

蓝的天气 我的爱是 Lemon Tree 喔不 管不管我

C G Am Em

3 3 4 5 5 - 5 6 6 2 2 0 5 1 1 1 1 1 1 2 3 5 5 3 3 5 5

一天一天 更爱你 我 不管不管不管爱会 苦苦地 海蓝

F G F G

5 4 4 4 2 3 2 2 0 0 5 5 6 6 5 5 1 1 2 3 3 2 2 0 0 5 5 6

蓝的天气 海蓝 蓝的天气 海蓝

F G C

6 5 5 1 1 2 3 3 2 2 0 2 2 2 3 2 1 1 1 1 - - - -





蓝的天气 我的爱是 Lemon Tree

Fine



# 想太多

词/张震岳 曲/张震岳 演唱/张震岳

 **#Gm — B**   
  **#Gm — B**   
  **4/4, = 104**   
  **Funk**

Guitar  | xx ↑↑↓↓↑↑↓↓ |

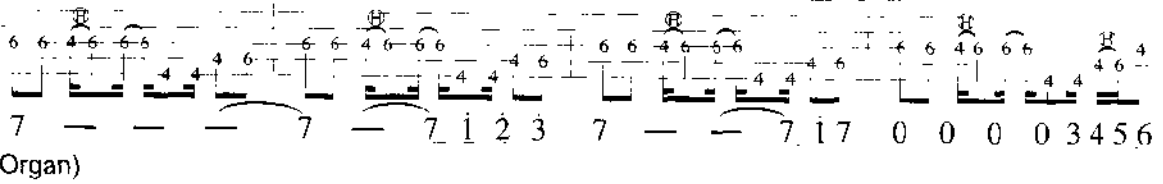
Bass 

(Organ)



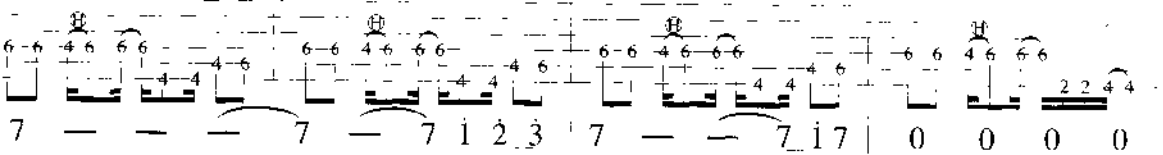



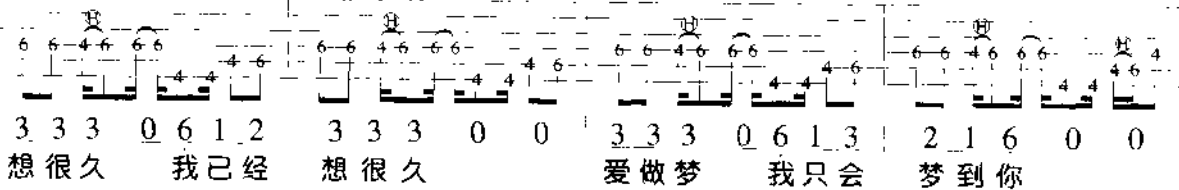





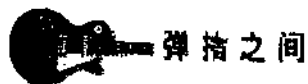

3 3 3 0 6 1 2    3 3 3 0 0    3 3 3 0 6 1 3    2 1 6 0 0

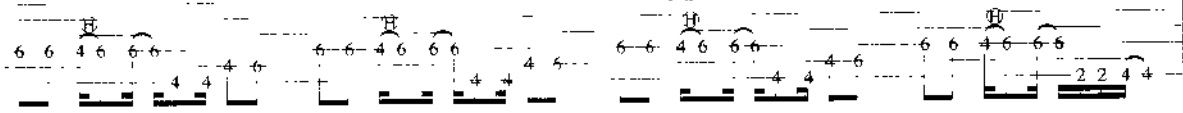
想很久 我已经 想很久 爱做梦 我 只会 梦到你



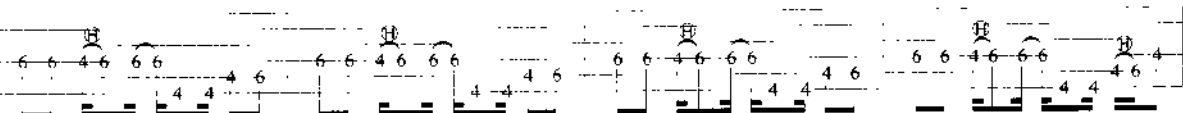

**#Gm**  
  
  
 3 3 3 0 6 1 2 3 3 3 0 0 3 3 3 0 6 1 3 2 1 6 0 0  
 麦当劳 我看你 在打工 好漂亮 是我喜 欢的人

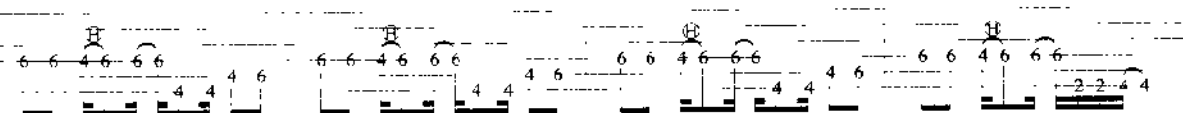
**#Gm**  
  
  
 6 6 6 0 3 5 6 6 6 6 0 0 6 6 6 0 3 5 6 6 6 6 0 0  
 都不够 时间永 远不够 吃汉堡 想每天 吃八个

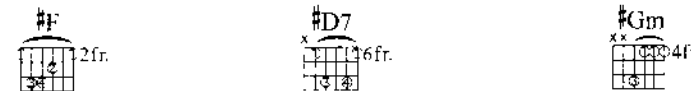
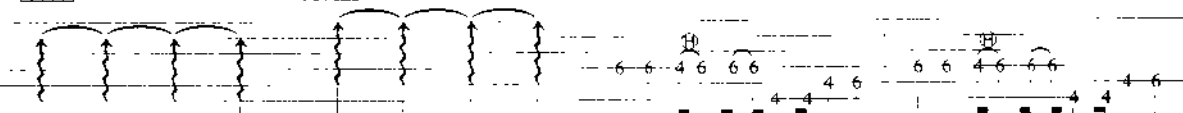
**#Gm**  
  
  
 6 6 6 0 3 5 6 6 6 6 0 0 6 6 6 0 3 5 6 6 5 6 0 0  
 我也要 在麦当 劳打工 没下班 我看我 先回家

**#F** 2fr. **#D7** 6fr. **#Gm** 4fr.  
  
  
 7 — 7 7 1 7 7 — 7 6 7 7 7 6 6 — 0 3 1 6 6 5 3 3 0 0  
 啊 没有用 是我想 太多 啊

**#F** 2fr. **#D7** 6fr. **#Gm** 4fr. **#Cm** 4fr.  
  
  
 7 — — — 7 — — — | 3 3 3 3 3 3 6 1 1 3 3 2 2 1 2 2 —  
 啊 啊 已经想好如果相 遇 要说些什么



#F Bmaj7 #Cm #D7 #Gm #C7

2.2 2 2225 772 4 5 3 2 3 3 0 3 3 2 2 4 4 4 3 0 3 2 1 7 1 3 3 6 7  
 可是遇见了 你之后 不敢跟你说 是 我太在乎完美 不 想知道结果 我没

#Cm #D7 #Gm #Cm

1 — 0 2 1 3 2 — — — 3 3 3 3 3 3 6 1 1 3 3 2 2 1 2 2 —  
 用 没有用 爱情像是一扇永远 开不了的门

#F Bmaj7 #D7 #Cm #D7 #Gm #C7

2 2 2 2 2 2 5 7 7 2 4 5 3 2 3 3 0 3 3 2 2 4 4 4 3 0 3 2 1 7 1 3 3 6 7  
 孤单的我在 门前 是 如此的清冷 谁 给我一把钥匙 也 许是我白问 想太

#Cm #D7 #Gm #Cm

1 — 0 2 4 4 3 2 1 3 2 1 6 3 2 1 6 6 — 6 5 6 6 1 1 6 1 0 3  
 多 耶 (Organ)

#F Bmaj7 #Cm #D7 #Gm #C7

3 2 2 1 2 2 1 6 6 1 3 2 2 1 1 0 0 1 7 1 2 3 4 4 3 3 3 2 1 7 1 3 3 3 2 1 |

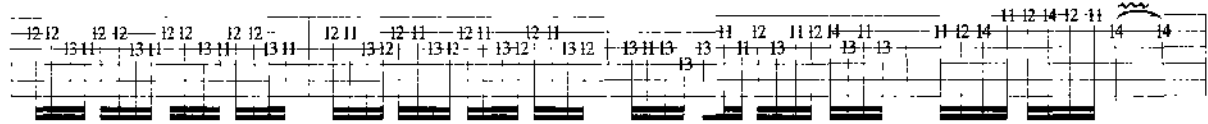

#Cm #D7 #Gm #Cm  
  
  
 116511651651165 | 1766176617661766 | 656467516712616 | 712345432 —

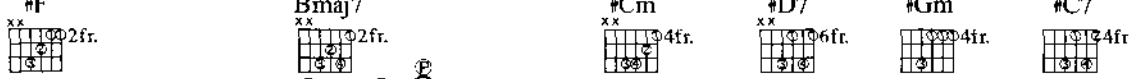
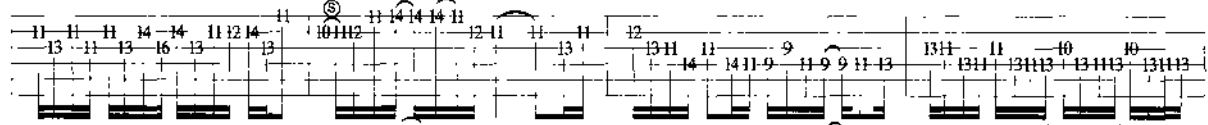
#F Bmaj7 #Cm #D7 #Gm #C7  
  
  
 767576262671263 | 713555317·67 | 16545421421123 | 6532532353235323

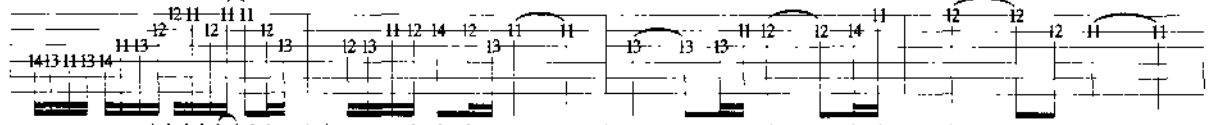
#Cm #D7 #Gm #Cm  
  
  
 4323456143133316 | b6 67 1 2 167 — | 6· 67 1· 2 3 | 4· 1 7 —

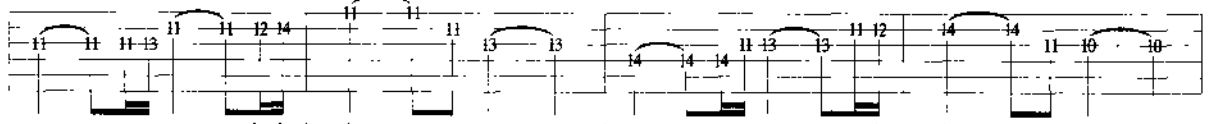
#F Bmaj7 #Cm #D7 #Gm #C7  
  
  
 5· 5 6 7· 1 2 | 3· 7 6 — | 4· 4 5 6· 7 1 | 2· 5 b5 —

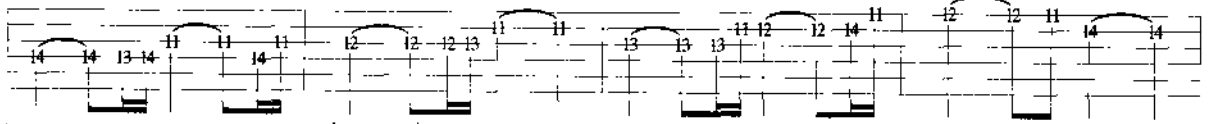
#Cm #D7 #Gm #Cm  
  
  
 4· 3 4 5· 4 5 | b6· b6 6 7 — | 6· 6 7 1· 2 3 | 4· 3 2 —

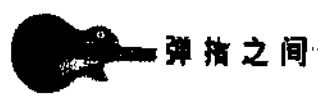

**F** (xx0232) 2fr.    **Bmaj7** (xx0232) 2fr.    **Cm** (xx3200) 4fr.    **D7** (xx0232) 6fr.    **Gm** (xx3200) 4fr.    **C7** (xx0232) 4fr.

14 14 12 14 11 12 14 11 14 12 12 | 14 14 14 13 13 11 12 14 14 12 11 11 13

2̣. 1̣ 2̣ 7̣ 1̣ 2̣ | 3̣. 2̣ 1̣ — | 4̣. 4̣ 5̣ 6̣. 7̣ 1̣ | 2̣ 1̣ 7̣. 6̣

**Cm** (xx3200) 4fr.    **D7** (xx0232) 6fr.    **Gm** (xx3200) 4fr.    **Cm** (xx3200) 4fr.

11 11 13 11 12 14 | 11 11 14 11 11 11 13 13 13 11 12 12 14 11 12 12 11 11

7̣. 6̣ 7̣ | 1̣ 2̣ 3̣. 2̣ 3̣ — | 6̣. 6̣ 7̣ | 2̣ 3̣ | 4̣. 1̣ 7̣ —

**F** (xx0232) 2fr.    **Bmaj7** (xx0232) 2fr.    **Cm** (xx3200) 4fr.    **D7** (xx0232) 6fr.    **Gm** (xx3200) 4fr.    **C7** (xx0232) 4fr.

11 11 11 13 11 12 14 | 11 11 13 13 14 14 14 11 13 13 11 12 14 14 14 11 10 10

5̣. 5̣ 6̣ 7̣. | 1̣ 2̣ | 3̣. 7̣ 6̣ — | 4̣. 4̣ 5̣ 6̣. 7̣ 1̣ | 2̣. 5̣ b5̣ —

Fade Out



# 40 左右手的技巧【三】 Guitar 切音与闷音

所谓切音 (Stacato), 就是右手击弦后, 将延音在瞬间停止的效果。而所谓闷音 (Mute), 就是开始便将右手掌侧面靠在弦上, 使之不发出声音, 而让Pick在弦上摩擦所产生的声音。使用左手做切音, 算是在民谣吉他演奏中, 较高段的弹奏方式, 它可以带来较丰富的弹奏变化与清脆的音色, 通常这种切闷技巧的表现, 在 Funk 音乐中最具代表性。练习之重点着重在左手压弦与右手持 Pick 交替时之韵律感。

## 一、左手切音法

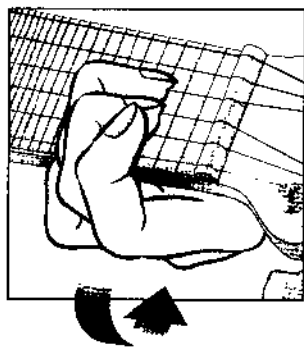
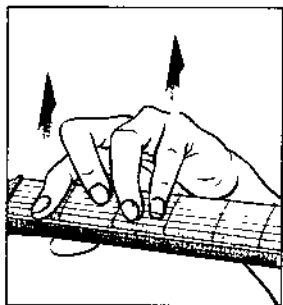

## 二、右手切音法

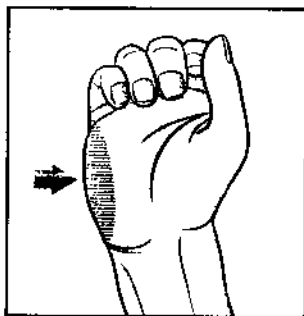
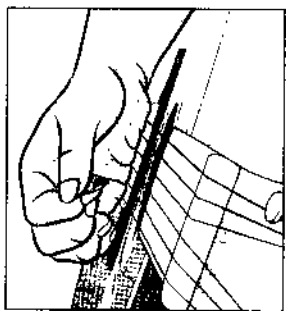



# 情非得已

电视剧“流星花园”预告片片尾主题曲

词/张国立 曲/杨小康 演唱/庾澄庆



C—D



C—D



4/4 ♩ = 107



Soul

C G Am F Em

0 0 0 5 6 5 5 — — — 5 6 2 3 2 1 1 — — 1 — 7 —

(Organ)

F G C C C

5 6 6 5 — — 5 — — — 0 0 0 3 4 | 5 4 4 5 5 4 3 2

难以 忘记 初次见你

G/B Am Em F

2 — 0 3 2 2 1 1 1 1 3 5 5 — — 1 1 2 1 1 1 0 1

一双 迷人的 眼睛 在我 脑海里 你



Em F G C

7 6 6 5 5 — | 1 1 1 3 1 3 2 2 — | 0 3 3 4 5 4 3 4 5 4 3 2 |

的身影 挥散不去 握你的双手感觉你的温柔

Em7/B Am Em F

2 — — 3 2 2 1 1 1 1 1 3 6 6 5 5 — | 0 5 6 1 1 1 0 2 |

真的有点透不过气 你的天真我

Em F G G

7 6 6 5 5 5 5 | 6 1 1 6 1 6 1 2 2 — | 0 5 3 2 2 1 6 7 6 5 5 5 1 2 |

想珍惜 看到你受委屈我会伤心 呜喔喔 Oh—— 只怕我

C Em7/B Am Em

3 2 2 1 1 1 1 5 5 — — | 3 5 3 3 3 2 2 3 4 3 3 — — | 3 2 |

自己会爱上你 不该让自己靠得太近 怕我

F Em F G

2 1 1 6 1 2 5 6 6 5 5 — | 5 5 6 1 1 6 1 6 1 2 2 — | 0 5 1 2 |

没什么能够给你 爱你也需要很大的勇气 只怕我



C G/B Am Em

3 2 2 1 1 1 5 5 — — 3 5 3 3 3 2 2 3 4 3 3 — — 3 2

自己会爱上你 也许有天会情不自禁想念

F Em F G C

2 1 1 6 1 1 2 5 5 — — 5 5 6 1 1 6 3 2 1 1

只让自己苦了自己 爱上你是我情非得已

C G C G Am

0 0 0 3 4 : 1. 2.

难以

(E.G Solo)

0 0 0 0 0 5 6 1 2 3 5 3 2 1 7 1 2 1 1 1 4

F Em F G C G Am

4 5 6 5 5 7 7 1 1 2 3 2 2 1 7 1 1 0 5 6 1 2 3 5 3 2 1 7 1 2 1 1 1 4



F Em F G Am Em

0 0 0 0 0 0 0 0 0 0 1 1 1 2 1 3 3 4 3 2 1 1 0 6

什么 原 因 耶 我

4 5 6 5 5 7 7 1 1 2 3 2 2 3 4 3

F G C C Em7/B Am Em

1 1 1 6 1 1 1 6 5 5 — — — 0 1 1 1 1 5 6 6 5 5 1 1 1 0 6

竟然又会遇见 你 我 真 的 真 的 不 愿 意 就

F G A Em7/B #Fm7/#C D

3 2 2 1 1 6 1 2 2 — 0 1 2 3 3 — 0 5 1 2 3 2 2 1 1 1 1 6

这样陷入爱的陷阱 呜 Oh (转D调) 只怕我自己会爱上你

#Fm7 Bm #Fm7 G

6 5 5 — 3 5 3 3 3 2 2 3 4 3 3 — — 3 2 2 1 1 6 1 2 5 6

不 该 让 自 己 靠 得 太 近 怕 我 没 什 么 能 够 给 你

#Fm7 (2fr.) G A D

6 5 5 — 5 5 6 1 1 6 1 6 3 2 2 — 0 5 1 2 3 2 2 1 1 1 1 6 |

爱你 也需要很大的勇气 只怕我 自己会爱上你

#Fm7 (2fr.) Bm (2fr.) #Fm7 (2fr.) G

6 5 3 5 6 5 — 3 5 3 3 3 2 3 4 3 3 — — 3 2 2 1 1 6 1 1 2 5 |

也许 有天会情不自禁 想念 只让自己苦了自己

#Fm7 (2fr.) G A D G A

5 — — 5 5 6 1 1 6 3 2 1 1 1 — — 5 5 6 1 1 6 3 2 1 1 |

爱上 你是我情非得已 爱上 你是我情非得已

D D A Bm (2fr.) G #Fm (2fr.)

1 — — — 0 0 0 0 0 0 0 0 0 0 0 0 |

0 5 6 1 2 3 5 3 2 1 7 1 2 1 1 3 3 4 4 5 6 5 5 7 7 1

(E.G Solo)



G A D A Bm G #Fm

10 12 12 14 12 12 10 9 10 10 7 9 11 10 11 9 7 6 7 9 7 7 5 7 7 8 8 10 12 10 10 9 9 10

1 2 3 2 2 1 7 1 | 1 5 6 1 2 3 5 3 2 1 | 7 1 2 1 1 3 3 4 | 4 5 6 5 5 7 7 1 |

G A D

10 12 12 14 12 12 10 9 10 10 10 10 10 1/2 C D (9) 8 7 6 7 5 6 5 3 4 5 5 5

1 2 3 2 2 1 7 | 1 - - - - - 1 - - - - - 1 - - - - -

D D D

Mute

0 0 0 0 0 0 0 0

Fine



# 当我开始偷偷地想你

词/张雨生 曲/张雨生 演唱/张惠妹



Em



Em



4/4 = 104



Soul

Em



(A.G.)

Em

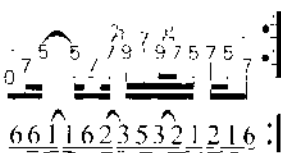

Am7

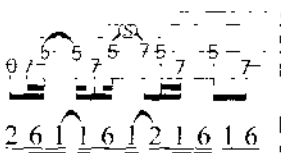

Em



Am7



E



Am7

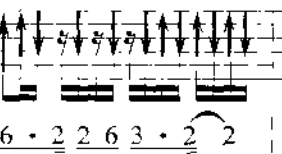

Em7



D



一条漫长路和一个  
一颗混乱的心和一窗

Bm



Em

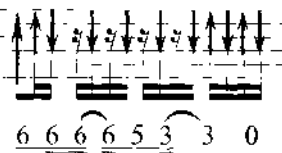

拉长的 身影  
漆黑的 风景

Am7



这次我离开你  
这次我离开你  
你是不必讶异  
你是无须欢欣

Em7



应该有风有雨  
应该有风有雨  
黄叶跌满一地  
挥挥衣袖而已



D Bm Em Bm D Em G

6 · 7 7 6 5 5 5 3 5 5 6 6 5 6 6 0 5 · 5 5 6 7 · 7 1 7 6 · 6 6 5 3 3 0

换 过 一 季 心 情 和 落 落 寡 欢 的 面 具 从 今 以 后 我 们 不 再 有 任 何 关 系  
云 彩 阳 光 与 我 的 灵 魂 还 留 在 原 地

Bm D Cmaj7 Bm D Em G

5 · 5 5 6 7 1 7 6 — 2 3 2 1 6 3 5 6 5 3 5 · 5 5 6 7 · 7 1 7 6 · 6 6 5 3 0

从 今 以 后 你 就 是 你 从 今 以 后 我 们 不 再 有 任 何 关 系

Bm D Cmaj7 C Dadd9

5 · 5 5 6 7 1 7 6 — 2 3 2 6 · 1 1 — 2 — 0

从 今 以 后 我 不 怪 你 恶 意 的 失 忆 喔

Am7 Em D Bm Cmaj7 Bm

2 · 6 1 6 2 2 2 6 1 2 3 · 2 1 7 6 6 6 5 6 3 7 · 6 5 2 5 5 5 6 7 1 7 1 7 6 6 5 3

当 我 开 始 偷 偷 的 想 你 当 我 开 始 偷 偷 的 哭 泣 爱 恋 一 如 蟒 蛇 般 缠 紧 失 控 的 情 绪

Am7 Em D Bm Cmaj7 D

2 · 6 1 6 2 2 2 6 1 2 3 · 2 1 7 6 6 6 5 6 3 7 · 6 5 2 5 5 5 6 7 1 7 1 7 6 6 1 7 6 6 5

如 果 我 们 不 会 再 相 遇 你 是 不 是 就 把 我 忘 记 或 许 这 是 最 好 的 结 局 就 让 我 偷 偷 地 想





Em Am7 Em Em

你 (A.G)

6 6 1 1 6 1 2 1 6 1 6 6 6 1 1 6 2 3 5 3 2 1 2 1 6 2 6 1 1 6 1 2 1 6 1 6 6 6 1 1 6 2 3 5 3 2 1 2 1 6

Am7 E Am7 C/G D/A D/E E

就让我 偷偷地 想 你

2 6 1 1 6 1 2 1 6 1 6 6 6 1 1 6 3 0 0 :| 1 7 6 6 1 7 6 6 5 6

D/E E D/E E D/E E D/E E

啊..... 这次我离开你 喔.....

0 0 0 0 5 6 6 0 0 6 5 5 5 5 5 6 6 5 3 3 3 2 1

D C C B Em Em Bm D

(A.G) 从 今以后我们不再

1 0 2 3 2 1 6 6 6 1 1 6 1 2 1 6 1 6 6 6 1 1 6 2 3 5 3 2 1 2 1 6 5 5 5 6 7 7 1 7

E G Bm D Cmaj7 Bm Am7 Am7/G

有何关系 从 今以后你 就是 你 恶意的 失忆 喔.....

6 6 6 6 5 3 3 0 5 5 5 6 7 1 7 6 2 3 2 3 1 1 0 2 3



Bm<sup>#F</sup> Bm<sup>#F</sup> Am7 Em

2 — — — 0 0 0 0 2 · 6 1 6 2 2 6 6 1 2 3 · 2 1 7 6 6 6 5 6 3

当 我 开 始 偷 偷 地 想 你 当 我 开 始 偷 偷 地 哭 泣

D Bm C Bm Am G Am7 Em

7 · 6 5 2 5 5 5 6 7 1 7 | 1 7 6 6 5 3 — | 2 · 6 1 6 2 2 6 6 1 2 | 3 · 2 1 7 6 6 6 5 6 3

爱 恋 一 如 蟒 蛇 般 缠 紧 失 控 的 情 绪 如 果 我 们 不 会 再 相 遇 你 是 不 是 就 把 我 忘 记

D Bm Cmaj7 D Asus4 A Em E<sup>#G</sup> Am7 C/G D/A

7 · 6 5 3 5 5 5 6 7 1 7 | 1 7 6 6 1 7 6 6 5 | 6 — 0 0 | 1 7 6 6 1 7 6 6 5

或 许 这 是 最 好 的 结 局 就 让 我 偷 偷 地 想 你 就 让 我 偷 偷 地 想

E E C D E E C D

6 — 0 0 | 1 7 6 6 0 0 | 1 7 6 6 0 0 6 | 6 — — —

你 偷 偷 地 偷 偷 地 想 你

Fine



# 水蓝色眼泪

词/张雨生 曲/张雨生 演唱/张惠妹



Bm



Bm



4/4 = 100



Funk

Acoustic Guitar Chord

String

Chord progressions: Bm, #Fm7, Em7, #Fm7

String numbers: 0 0 0 0 0 0 0 0 0 0 0 0 0 0 6 7 1 2

Chord progressions: Bm, #Fm7, Em7, #Fm7

String numbers: 3 7 5 2 3 - 7 - 6 1 3 6 5 - - 0

Chord progressions: Bm, #Fm7, Em7, #Fm7

String numbers: 0 3 3 3 3 0 6 3 2 3 2 2 - 0 6 1 1 1 1 2 2 2 3 3 2 2

从 我 眼 中 你 看 到 什 么 有 没 有 一 种 令 人 心 悸 的 坠 落  
 蓝 色 的 泉 彩 绘 了 子 夜 坠 落 的 重 量 产 生 一 些 音 乐





Bm 2fr. E Bm 2fr. E

6 - - 0 0 0 0 0 0 0 0 0 0 0 0 6 7 1 2

String

G 3fr. A 5fr.

3 . 6 6 3 3 2 . 5 5 - :

Bm 2fr. 2. E13 7fr. G 3fr. A 5fr.

6 5 3 3 2 2 1 6 6 - 0 3 3 5 5 3 5 1 7 7 6 5 3 5 3 5

水 蓝 色 眼 泪 是 心 碎 流 的 血 是 天 真 的 幻 灭 所 有

Bm 2fr. E13 7fr. G 3fr. A 5fr.

6 5 3 3 2 2 1 6 6 - 0 3 3 5 5 3 5 1 7 7 6 5 3 5 3 5

水 蓝 色 眼 泪 快 融 成 一 片 雪 让 我 的 忧 伤 冬 眠

Repeat Fade Out

Bm 2fr. #Fm7 2fr. Em7 #Fm7 2fr.

6 - - - - 6 1 1 2 2 3 3 5 5 6 6 1 1 -

嘿.....

Bm 2fr. #Fm7 2fr. Em7 #Fm7 2fr.

0 2 - 1 6 | 5 5 6 2 3 2 1 6 1 2 0 6 5 4 3 2 1 6 1 2 1 6 5 2 3 5 6 7 7 7 1 2 3 1 2 3

E. Guitar Solo

Fade Out



# G41 复根音的伴奏

复根音的伴奏方式，有别于三指法的重音伴奏方式。使用根音，五音，根音的复根音伴奏方式，弹奏起来宛如一把吉他加一把 Bass 吉他的感觉。

提到三根音的伴奏方式，那便得提提这位号称是“民谣吉他之父”的—Jim Croce (吉姆克劳契)，在Jim Croce的作品中，使用大量的三根音伴奏方式，再配上一把吉他做对位演奏，是想练习双吉他朋友们的必练经典作品，如果你弹腻了流行歌曲，那 Jim Croce 将是你最好的选择。

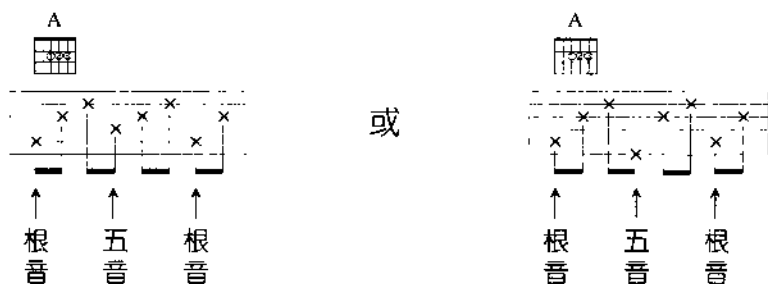

下面的练习也是经典的名作，Joan Baez (琼·拜尔)，在1975年得到全美的冠军歌曲，Diamond And Rust (钻石与铁锈)，也是三根音的精彩作品。大家可能少有机会听过，所以笔者仅列出前奏部份，如果您很喜欢，再去买 CD 听罗。



▶ 范例一

The diagram illustrates various chord shapes and fingerings on a guitar fretboard:

- Row 1:** Em (open), Em9 4fr., Em (open), Em (open), Em9 4fr., Em (open), Em9 4fr.
- Row 2:** Em (5fr.), Em9 (4fr.), Em (5fr.), Em (7fr.), Em (5fr.), Em (7fr.), Em (7fr.), Am9 (2, 3, 5tr.).
- Row 3:** Em (3fr.), B7 (open), B7/E (open), Em (open).
- Row 4:** Em9 4fr., Em (open), Em (open), Em9 4fr., Em (open).

Fingerings and fret numbers are indicated by numbers 1-5 and letters 'f' (finger) and 'tr.' (trill) on the fretboard lines.



# New York's Not My Home

Jim Croce



<p>A9</p>	<p>A9/bA</p>	<p>A9/G</p>	<p>A9#b</p>
<p>0 0 0 0   0 0 0 0 0 0 0 0 0 0 0 0 0 0</p>			

<p>Bm7</p>	<p>Fdim7</p>	<p>Amaj7</p>	
<p>0 0 0 0 0 0 0 0 0 0 0 0 0 0 0 0 0 0 0 0</p>			

<p>A9</p>	<p>A9/bA</p>	<p>A9/G</p>	<p>A9#b</p>
<p>0 0 0 5 5 5 6 6 6 5 5 6 6 0 - 0 5 5 5 6 6 6 3 3</p>			

Well thing were spinnin round me  
Thought all the streets are crowded

And all my thoughts were cloudy  
There's something strange about it





Bm7 2fr. Fdim7 Amaj7

0 0 1 3 2 2 1 3 3 2 2 1 2 3 3 5 5 6 6 - | 0 0 0 0

And I had be - gan to doubt all the thing that were me  
Lived there about a year and I never once felt at home

A9 6fr. A9#4A 6fr. A9/G 5fr. A9/#F 4fr.

0 0 0 5 5 6 6 6 6 5 5 6 6 0 5 5 5 5 6 6 6 6 6 6 6 3 3

Been in so many places You know I've run so many races  
I thought I'd make the big time I learned a lot of lessons of quick, and now I'm

Bm7 2fr. Fdim7 Amaj7 #Fm 2fr.

0 0 5 3 2 2 1 3 3 3 2 2 1 2 1 3 5 5 6 6 . 5 | 1 6 5 1 1 6 5 1

And looked into the empty faces of the people of the night And something is just not right  
telling you, That they were not the nice kind And it's been so-long since I have felt fine

Amaj7 #Fm 2fr. Amaj7 #Fm 2fr.

0 1 1 1 1 1 1 2 3 2 2 1 6 0 - 1 2 3 2 1 6 6 -

1. 'Cause I know that I gotta get out here I'm so a - lone  
2.3. That's the reason that I gotta get out here I'm so a - lone

Amaj7 #Fm 2fr. D Amaj7

0 1 1 1 1 1 1 2 3 2 2 1 6 5 1 6 6 6 6 6 6 3 2 | 1 - - -

Don't you know that I gotta get out of here 'Cause New York's not my home  
Don't you know that I gotta get out of here 'Cause New York's not my home







Amaj7                      #Cm                      Bm7                      E7

know it's kind of late I hope did-n't wake you But what I  
 know it's kind of strange But every time I'm near you I just run

Dmaj7                      #Fm11                      Em7                      A

got to say can't wait I know you'd under-stand  
 out of things to say I know you'd under-stand

Amaj7                      #Cm                      Bm7                      E

Every time I tried to tell you the words just came out wrong So I'll  
 Every time I tried to tell you the words just came out wrong So I'll

D                      #Ddim                      #C7                      #Fm                      D

G                      #Gdim7                      #F7                      Bm7                      G



Amaj7 E D Amaj7 E

3 3 4 3 3 2 0 3 2 1 — 0 0 0 0 0 1 2 :

have to say I love you In a song Yeah I  
 have to say I love you In a song

D Amaj7 E Amaj7 #Cm

1 — 0 0 0 0 0 0 || 0 0 0 0 0 0 0 0

Song

D Dmaj7 A Dmaj7 #Fm11

Guitar 3

0 0 0 0 0 0 0 1 2 2 3 5 3 5 6 6 5 5 0 0 0



**Bm7** **E7** **Amaj7** **#Cm**

**E7** **A7** **Dmaj7** **#Fm11**

**Bm7** **E7** **D** **#Ddim**

**Em7** **A7** **G** **#Gdim7**

0 4 3 2 1 1 2 | 3 2 2 — 1 2 | 2 3 5 1 2 2 | 3 — — —

0 4 3 2 1 1 2 | 3 2 2 — 1 2 | 2 3 5 1 2 2 | 3 — — —

0 6 6 6 6 | 6 6 7 7 6 6

0 4 3 2 1 1 7 | 7 6 6 7 6 5 || 0 0 0 0 | 0 0 0 0

Every time the time was right all the  
 Every time I tried to tell you the



**#Cm7** **#Fm** **D** **Amaj7** **E**

5 5 3 2 2 | 1 — 0 1 2 3 3 4 3 | 3 2 0 3 2

words just came out wrong So I'll have to say I love you in a  
 words just came out wrong So I'll have to say I love you in a

**#F7** **Bm7** **G** **D** **A7**

2 4 3 2 2 | 2 4 3 0 0 0 2 3 2 3 2 3 1 2 0 2 0 2 2 0

**D** **Amaj7** **E** **Amaj7** **#Cm**

1 — 0 0 | 0 0 0 1 2 3 5 5 5 6 | 5 0 0 0

song song Yeah I know it's kind of late

**G** **Dmaj7** **A7** **Dmaj7** **#Fm11**

0 0 2 2 3 4 | 0 2 2 2 0 2 0 2 0 2 2 0 2 2 0 2 0 2 3

**Bm7** **E7** **Amaj7** **#Cm**

0 4 4 3 2 3 | 3 2 — 5 3 5 3 5 3 6 6 5 5 | 5 — 0 0

I hope I did - n't wake you But there's something that I just got to say

**Em7** **A** **Dmaj7** **#Fm11**

2 0 0 3 3 3 | 2 0 2 0 2 0 2 0 2 0 2 0 2 0 2 0 2 0 3



**Bm7** **A**

② ② 2fr.

0 4 4 3 2 3 3 3 | 3 2 — 0

I know you'd under-stand

**Em7** **A**

0 2 0 0 0 3 3 3 | 2 0 0 2 0 2

**Amaj7** **#Cm** **Bm** **Dm** **E7**

0 0 0 0 | 0 0 0 0 | 0 0 0 0 | 0 0 0 0

**Dmaj7** **#Fm11** **Em7** **Gm** **A6**

0 2 0 2 0 2 0 0 | 2 0 0 0 3 | 0 2 0 3 3 | 5 3 3 3 | 2 2 2 2

**Amaj7** **#Cm** **Bm** **Dm** **E7**

0 0 0 0 | 0 0 0 0 | 0 0 0 0 | 0 0 0 0

**Dmaj7** **#Fm11** **Em7** **Gm** **A6**

0 2 2 0 | 0 2 0 0 3 | 0 2 0 3 3 | 5 3 3 3 | 2 2 2 2





Amaj7

0 0 0 0

Dmaj7

0 2 2 2 2

Fine



# Guitar 42 五度圈

在音阶中，调子的排列顺序，每个都是相差完全五度的排列方式，此种体系，我们称之为「五度圈」。

## 一、以属音/Dominant为排列方向（顺时针方向）

将原来音阶中的第五度音变成以此音为主音（第一度音）的新音阶。仔细推算此一音阶后可发现，旧音阶中的第四度音（Sub Dominant：下属音）必须升半音，方可成为新音阶中的第七度音（Leading Tone：导音）故以一个升记号排列。

由图可知 A 大调有 3 个升记号， $\sharp 4$ 、 $\sharp 1$ 、 $\sharp 5$ 。

## 二、以下属音/ Sub Dominant为排列方向（逆时针方向）

将原来音阶中的第四度音变成以此音为主音（第一度音）的新音阶。仔细推算此一音阶后可发现，旧音阶中的第七度音（Leading Tone：导音）必须降半音，方可成为新音阶中的第四度音（Sub dominant：下属音）故以一个降记号排列。

由图可知  $\flat B$  调有 2 个降记号  $\flat 7$ 、 $\flat 3$ 。

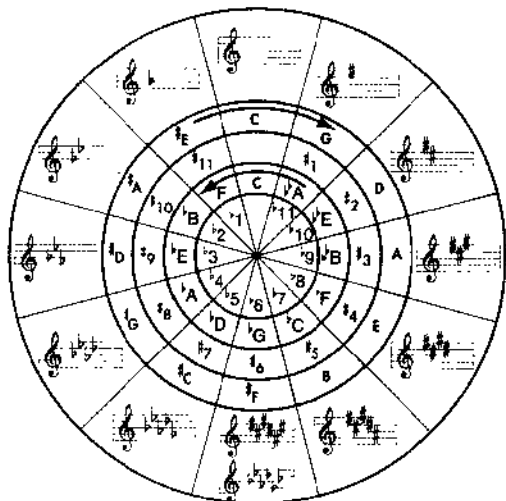

※上图中之数字表该调之变音数





### 三、口诀记法 ( Fa, Do, Sol, Re, La, Mi, Si )

调性	G	D	A	E	B	F	C	
五度圈的 口诀记法	4	1	5	2	6	3	7	四度圈的 口诀记法
	$\flat C$	$\flat G$	$\flat D$	$\flat A$	$\flat E$	$\flat B$	F	← 调性

依口诀音 Fa, Do, Sol, Re, La, Mi, Si 记忆, 箭头往右表五度圈, 在口诀音上加注升记号, 如A调有3个变音记号, 分别是Fa, Do, Sol。相反的,  $\flat B$  调便有 2 个变音记号, 分别是 Si, Mi。了解吗? 背下口诀音, 了解五度音更加如虎添翼。

### 四、代用性质

如果我们将五度圈上各调之关系小调也加上, 更可做为和弦替代的依据。

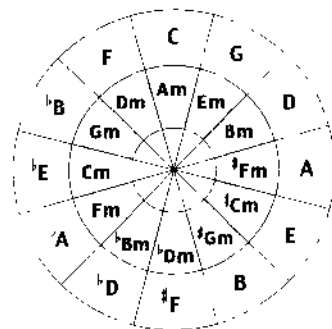

### 五、五度圈的相关应用

在这个五度圈中, 除了可以很快地找出与每个大调相差一个完全五度的调性外, 更重要的一点是在每个大调的变音记号下, 比如说D大调有两个变音记号( $\sharp F$ 、 $\sharp D$ )。如果我们把它运用到转调上, 则所有遇到F属性与C属性的和弦均须加注升记号, 方可成为D大调的和弦, 即 C Dm Em F G Am B $\flat$  → D Em  $\sharp F$  G A Bm  $\sharp C$ 。另外值得一提的是, 以C大调为基准, 顺时针方向一直到四个变音记号→C G D A E, 以及逆时针方向一直到四个变音记号→C F $\flat$  B $\flat$  E $\flat$  A, 都是吉他演奏上重要调性, 如此一来你可以从五度圈上知道有那些调性是常用的。





例如方C 十调性 C 十调性 四 五 六 七 八 九 十 十一 十二 十三 十四 十五 十六 十七 十八 十九 二十 二十一 二十二 二十三 二十四 二十五 二十六 二十七 二十八 二十九 三十 三十一 三十二 三十三 三十四 三十五 三十六 三十七 三十八 三十九 四十 四十一 四十二 四十三 四十四 四十五 四十六 四十七 四十八 四十九 五十 五十一 五十二 五十三 五十四 五十五 五十六 五十七 五十八 五十九 六十 六十一 六十二 六十三 六十四 六十五 六十六 六十七 六十八 六十九 七十 七十一 七十二 七十三 七十四 七十五 七十六 七十七 七十八 七十九 八十 八十一 八十二 八十三 八十四 八十五 八十六 八十七 八十八 八十九 九十 九十一 九十二 九十三 九十四 九十五 九十六 九十七 九十八 九十九 一百

C → D7 → G  
C →  $\sharp$ Fdim → D7 → G  
C → Bm → D7 → G



以下之远系调和弦，可供大家做为使用上的参考：

### C 大调转 E 大调

C → Em → B7 → E  
 C → Am → B7 → E  
 C → Dm → B7 → E

### C 大调转 D 大调

C → Em → A7 → D  
 C →  $\sharp$ Fm → A7 → D  
 C → Em → Bm → A7 → D

### C 大调转 A 大调

C →  $\sharp$ C dim → Edim → E → E7 → A  
 C → C dim →  $\flat$ E dim → E7 → A  
 C → D dim → Fdim → A  
 C → B dim → E7 → A



# 爱的初体验

词/张震岳 曲/张震岳 演唱/张震岳



Gm—G



Gm—G



4/4 ♩ = 120



Soul

Drum 4 Bars

Gm

Gm

Gm

0 0 0 0 0 0 0 0 0 0 0 0 0 0 0 0

Gm

Gm

Gm

0 3 3 3 3 3 2 1 | 6 - - 0 0 3 3 3 2 1 6 1 2 - - 0

如 果 说 你 要 离 开 我 请 诚 实 点 来 告 诉 我

D7

Gm

0 1 2 1 2 1 2 1 3 - - 0 0 3 3 3 3 3 2 1 6 - - 0

不 要 偷 偷 摸 摸 地 走 像 上 次 一 样 等 半 年





Gm Gm Cm

0 3 3 3 3 2 1 6 - - 0 0 3 3 3 2 1 6 1 2 - - 0

如果说你真的要走 把我的相片还给我

D7 Gm

0 1 2 1 2 1 2 1 3 - - 0 0 3 3 3 3 2 1 6 - - 0

在你身上也没有用 我可以还给我妈妈

Gm C G

0 5 6 5 || 6 · 4 4 - | 0 5 6 5 | 6 · 3 3 -

什么天长地久 只是随便说说

A D

0 5 6 5 3 · 2 2 - | 0 2 3 6 | 6 5 5 5 -

你爱我哪一点 你也说不出口



D #C C G

0 5 6 5 | 6 · 4 4 - | 0 5 6 5 | 6 · 3 3 -

你认识了帅哥 就把我丢一旁





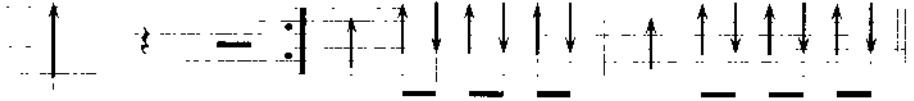

Gm  3fr.      D  2



0 3 3 3 3 3 2 1 :| 6 . 5 5 - | 0 1 2 1 |

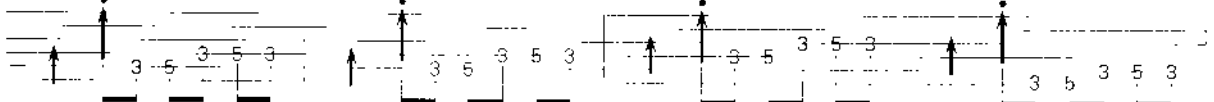

如果说你要离开 冷冬夜 什么天 %

Gm  3fr.      Cm  3fr.      D7  3fr.



6 - - 0 | 0 3 3 3 2 1 6 1 2 - - 0 | 0 3 3 3 3 3 2 1

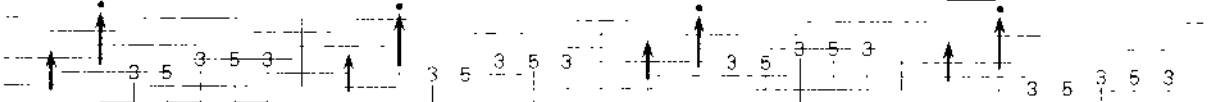

岁 是不是我的十八岁 注定要为爱情流

Gm  3fr.      Cm  3fr.      D7  3fr.



6 - - 0 | 0 3 3 3 2 1 6 1 | 2 - - 0 | 0 3 3 3 3 3 2 1

泪 是不是我的十八岁 注定要为爱情流

Gm  3fr.      Gm  3fr.



6 - - 0 | 0 3 3 1 6 1 3 2 5 6 5 3 5 6 1 3 2 | 1 - - 0 ||

泪 E.G. Solo Fine



# Tears In Heaven

Eric Clapton



Key

A — C









Play







A — C



Tempo







4/4

	A	E/G	#Fm	#Fm/E	D#F	D/E
						
0	0	0	0	0	0	0

	A	A	E#G	#Fm	#Fm/E	D9/#F	A/E
							
0	0	0	0	0	0	0	0
		3	1	5	5	3	2
			1	5	3	2	1
			2	3	2	1	2
			3	2	1	2	3

1.4. Would you know my name  
 2. Would you hold my hand

If I saw you in hea-  
 If I saw you in hea-

	E	A	E/G	#Fm	#Fm/E	D9/#F	A/E
							
2	0	0	0	0	0	0	0
		3	1	5	5	3	2
			1	5	3	2	1
			2	3	2	1	2
			3	2	1	2	3

-ven  
 -ven

Would it be the same  
 Would you help me stand

If I saw you in hea-  
 If I saw you in hea-



**E** **#Fm** **#C7/F** **#Cdim/E**

2 — — — 0 0 1 1 2 7 | 7 — — — | 0 0 7 7 2 6

-ven must I be strong And carry on  
-ven I'll find my way through night and day  
3. Be-youd the door There's peace I'm sure

**#F** **E#G** **#F#A** **D/B** **E7** **A** **E#G** **#Fm**

6 — 2 3 4 4 2 2 1 7 6 5 — 0 3 2 2 | 1 — — —

Cause I know I don't be- long Here in hea- ven  
Cause I know I just can't say Here in hea- ven  
And I know There'll be no more Tears in hea- ven

**#Fm/E** **D9/#F** **D9/E** **A** **A**

0 0 0 0 0 0 0 0 | 0 0 0 0 :|| 0 0 0 0

**C** **G/B** **Am** **D#F** **G** **D/A** **G** **D/A** **D/B**

0 6 6 5 5 4 3 2 4 2 5 2 3 3 — — — | 0 0 0 0

Time can bring you down Time can bend your knees

**C** **G/B** **Am** **D#F** **G** **D/A** **F**

0 6 6 5 5 4 3 2 4 2 5 2 3 3 — 0 3 5 6 6 — — —

Time can break you heart Have you beggin please Beggin please



Guitar 1

A E/G #Fm #Fm/E D/F A/E E

(转A调)

Guitar 2

A E/G #Fm #Fm/E D/F A/E E

§

A E/G #Fm #Fm/E D/B E7

ven Cause I know I don't be- long Here in hea-



A E/G #Fm #Fm/E D/#F D9/E A

1 0 0 0 0 0 0 0 0 0 0 0

ven Rit.....

C

6 Fine

# 44 左右手的技巧【四】

## 泛音

### Harmonics

在吉他上，弦因振动而发声时，除全体振幅所发出的基音（Fundamental）外，在每一个自然数等份弦上，也会因振动而发声，此时，在每一等份弦上所发出的声音，我们均谓之泛音（Harmonics）。所以，所有乐器的发声，都是基础音与所有不同等份倍率的泛音所组成。

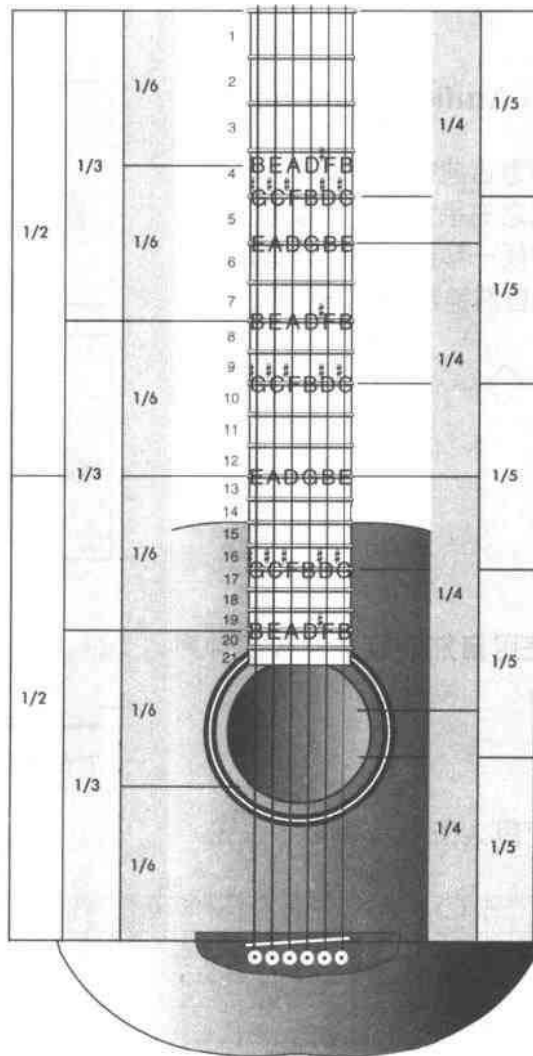



泛音又称钟音，可分自然泛音与人工泛音。

### 一、自然泛音 (Natural Harmonics) :

使用左手手指某些特定弦长的位置上，轻触在弦之上方，右手弹弦后，左手立即离开此弦，弹奏时须注意，弹弦与离弦为一瞬间动作。

谱上记号：

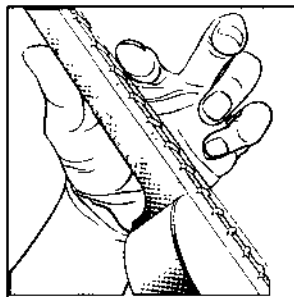

### 二、人工泛音 (Artificial Harmonics) :

此种技巧多为古典吉他上所使用，触弦及弹弦均以之右手食指、拇指来完成。左手可按住任一琴格，依照泛音原理，可以弹奏与自然钟音不同之音名。

谱上记号：

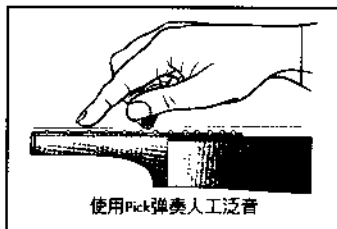
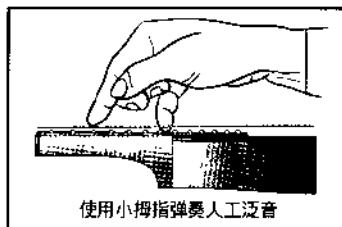

#### ▶ 范例一 》使用自然泛音弹奏校园钟声

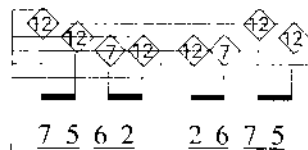

#### ▶ 范例二 》使用人工泛音弹奏G和弦



# 45 音乐类型【八】 Guitar Bossa Nova

Bossa-Nova 大多数的音乐人都直接叫它“巴沙(Bossa)”，是一种融合了爵士乐与拉丁音乐所形成的一种新音乐，也可以称之为“拉丁爵士”。这种节奏型态使用了大量的切分音型，再结合爵士乐里的摇摆与巴西音乐热情的感觉，听起来非常的舒服，音乐上没有爵士乐那么难懂，所以可以说是相当适合爵士入门听的音乐。

以下是几种常用的指型，特别是这种指型常常使用在爵士乐 II → V → I 的和弦进行模式中。

## 常用指型

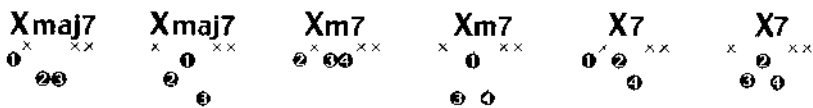

和弦指型中“X”代表此和弦可任意在指板上做移动，和弦名称就以移动到琴格上的音来命名。如下。

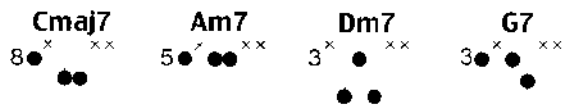

在伴奏上通常会把高音弦的部份刻意不弹，将手指往中间的声部靠，可以增加和声的饱和度。

## ▶ 范例一

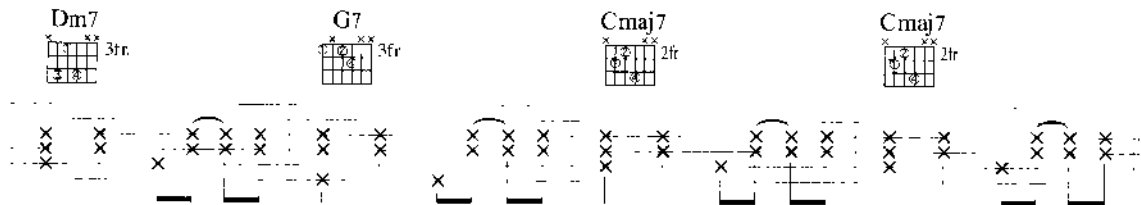

▶ 范例二 《变化根音（根音，五度根音）》

▶ 范例三 《加入过门音》

▶ 范例四 《加入打板技巧》

练完了以上的练习，是不是觉得这种弹法带有一点“摇摆”的感觉？还记得前面章节弹过的一种节奏型态叫“Swing”吗？二者都是使用根音与五度音的变化来做摇摆的感觉，只不过Bossa的摇摆多半使用8Beat的感觉，而Swing节奏则使用大量的切分音，感觉上是有所不同的，请大家要多加研究研究。

Bossanova最近在流行音乐上一直引领一股热潮，从Stan Getz与Gilberto夫妇合作的专辑-Getz/Gilberto蝉联全美流行音乐排行榜与最近的巴沙女王“小野丽莎”都是很值得聆听的Bossanova专辑喔！



# 他的眼泪

词/白进法 曲/张翰群 演唱/林晓培

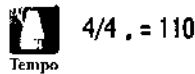

**DRUMS**

5 7 5 7 5 7

0 0 0 0 0 0 2 3 5 6 1 6

Dm7 5fr. G7 3fr.

Dm7 5fr. G7 3fr.

5 7 5 7

2 1 · 6 6 5 5 5 6 1 6

Dm7 5fr. G7 3fr.

2 1 · 6 6 5 5 · 2 3 2 2

Dm7 5fr. G7 3fr.

2 1 · 6 6 5 5 - 0 6 6 1 1 2 1 2 2 - 3 2 1 2 2 1 6 1

说 永 远 还 太 早 爱 的 变 化 太 难 预





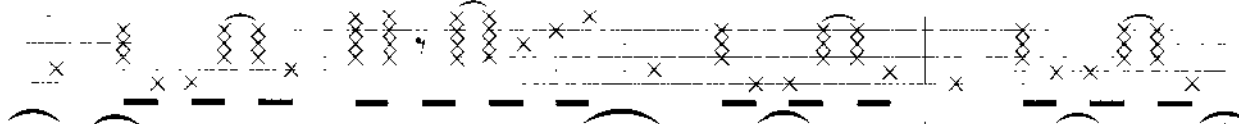



1 6 5 - - 0 0 0 6 6 1 | 1 2 1 2 2 - | 3 2 1 2 2 1 2 3 |  
 料 说爱我 太潦草 没有一次 说到做

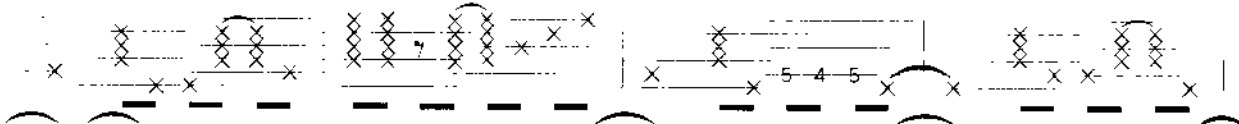



3 5 5 - - 0 0 0 3 4 5 | 5 5 4 4 3 2 1 2 2 2 3 2 0 1 2 3 |  
 到 多 少 次 你 和 我 一 言 不 合 就 拉 倒 每 一 次  
 或 许 是 你 对 情 人 的 条 件 特 别 挑 或 许 是



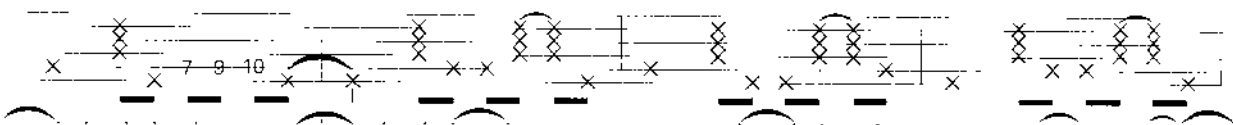

3 3 2 2 1 7 6 7 7 1 2 1 1 0 5 6 7 1 1 1 2 6 7 1 1 2 2 1  
 都 是 我 不 再 计 较 才 和 好 我 的 心 情 随 你 忽 低 又 忽 高  
 她 那 放 纵 的 美 丽 难 得 找 才 有 机 会 进 来 爱 情 里 轧 一 角



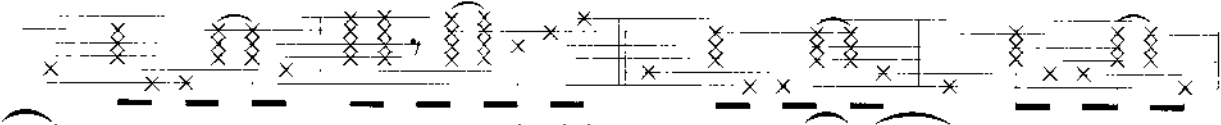

1 - - - 0 0 0 3 4 5 6 . 5 4 3 3 2 2 2 6 5 0 4 3 4 |  
 我 的 温 柔 比 不 上 她 的 眼 泪 我 的 防



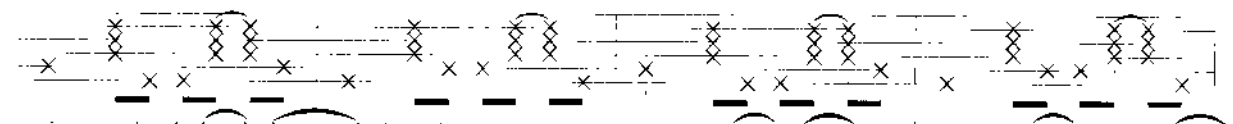

5 . 4 3 2 2 1 1 1 3 1 . 6 4 3 1 1 6 6 | 4 3 1 1 1 2 3 |  
 备 挡 不 住 她 的 侵 略 眼 睁 睁 看 你 从 眼 前 慢 慢 退

Cmaj7 3fr.      #Cdim7      Dm7 5fr.      G7 3fr.

3 - . 3 4 3 3 - 0 3 4 5 6 . 5 4 3 3 2 2 2 6 5 0 4 3 4 |

慢慢退 我的真心比不上她的娇媚 我的让

Em7 7fr.      Am7 5fr.      Dm7 5fr.      G7 3fr.

5 . 4 3 2 2 1 1 1 5 3 . 6 4 3 1 1 1 6 1 1 - 0 1 2 1 |

步挽回你一些些我该就此放手不再追

Cmaj7 3fr.      G7 3fr.      Dm7 5fr.      G7 3fr.

1 - - - 0 0 5 6 1 6 :| 3 1 - - 0 6 6 6 5 6 |

(G.T. solo)

Dm7 5fr.      G7 3fr.      Dm7 5fr.      G7 3fr.

0 3 2 1 2 6 1 0 6 5 3 2 1 2 3 5 5 6 1 2 3 5 5 0 6 6 1 6 5 - . 6 |

Dm7 5fr.      G7 3fr.

6 5 5 2 3 2 2 1 6 1 2 6 5 5 0 3 4 5

我的温 %



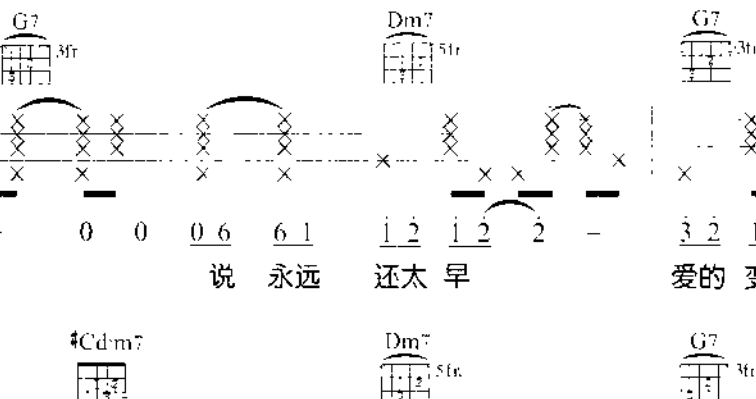

  
 1 - 0 0 0 6 6 1 | 1 2 1 2 2 - | 3 2 1 2 2 1 6 1
   
 说 永 远 还 太 早 爱 的 变 化 太 难 预

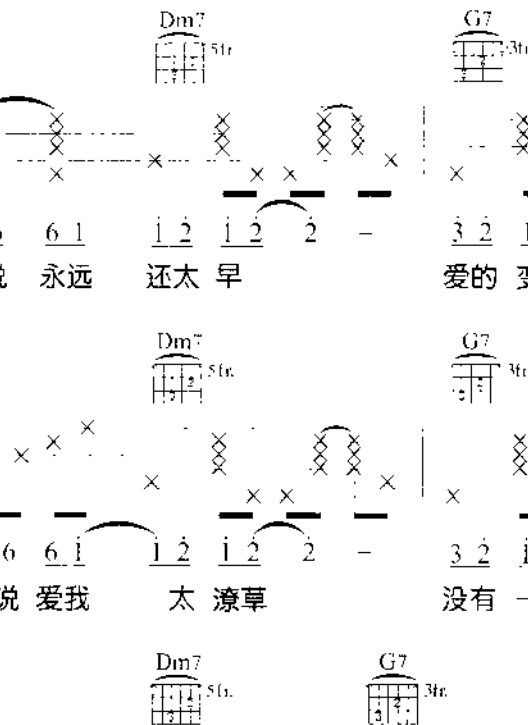
  
 1 6 5 - - 0 0 0 6 6 1 | 1 2 1 2 2 - | 3 2 1 2 2 1 2 3
   
 料 说 爱 我 太 潦 草 没 有 一 次 说 到 做

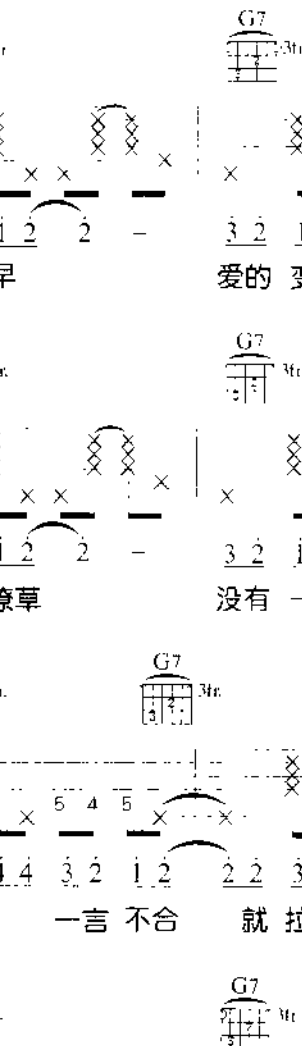
  
 3 5 5 - - 0 0 0 3 4 5 5 5 4 4 3 2 1 2 2 2 3 2 0 1 2 3
   
 到 多 少 次 你 一 言 不 合 就 拉 倒 每 一 次

  
 3 3 2 2 1 7 6 7 7 | 2 1 1 0 5 6 7 1 1 1 2 6 7 1 1 2 2 1
   
 都 是 我 不 再 计 较 才 和 好 我 的 心 情 随 你 忽 低 又 忽 高

  
 1 - - 0 0 5 6 1 6 2 1 6 6 5 5 2 3 2 2



x 
  
 2 1̣ · 6 6 5 5 - 5 6 1 6 | 2 1̣ · 6 6 5 5 · 2̣ 3 2 2

x 
  
 2 1̣ · 6 6 5 5 - 0 6 6 1 :|

Fade out



### 点弦练习

M L R L R H R M M L R L R H R H  
 12 5 8 12 5 8 12 5 8 12 5 8 13 5 8 13 5 8 13 5 8 13 5 8





# Guitar 46 增减和弦

## Diminished & Augmented

有些人做菜，总喜欢加油添醋一番，看看能不能有特别的味道出现。我想弹吉他跟做菜是一样的，传统的三和弦与七和弦，在歌曲的处理上，仍显得有点不足，所以有些人在会弹吉他之后，便喜欢在和弦上加加减减，为的就是希望让歌曲多点变化，避免很无聊的情况发生。现在我们就来谈谈这些加加减减的和弦。

### 一、增三和弦 (Augmented)

将一个和弦的第五度音程升高半音的做法，称之为增三和弦 (Augmented)。简写成 [Xaug] 或 [X+]。

原位                  第一转位                  第二转位

Xaug = 主音 + 大三度 + 大三度

Caug                  Eaug                  #Gaug

上图中，我们将增和弦做一个转位的组合，可以发现，以转位和弦的基础音做为根音，可以得到三种同音异名的增和弦，

即  $Caug = Eaug = \#Gaug$

$Caug = Eaug = \#Gaug$   
 $\#Caug = Faug = \#Aaug$   
 $Daug = \#Faug = \#Baug$   
 $\#Daug = Gaug = Baug$

增和弦在指板上的位置

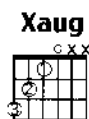

根音在第六弦之可移动和弦



根音在第五弦之可移动和弦



根音在第四弦之可移动和弦

使用时机

增和弦一般使用在半终止的乐句当中，甚么是“半终止”？好比说，如果和弦进行是C-Am-F-G- C以C和弦开头C和弦结尾，我们称为「完全终止」。那如果还没回到C和弦前而停留在G和弦上，那我们就叫它「半终止」。

好！在G和弦上你就可以加上Gaug和弦，让它有吊在半空中的感觉就对了。



## 二、减七和弦/Diminished

在每个三和弦上加入该和弦之第七级音后，我们可通称它们为七和弦，举凡在流行音乐、蓝调音乐上都广泛地被使用。如果我们在一个八度的音程中，将它平均分割成四组小三度的音程，即这四个音的组合，在乐理上，我们称之为减七和弦 (Diminished Seventh Chords)，简写成【Xdim7】或【X<sup>o</sup>】。

**Xdim7 = 主音+小三度+小三度+小三度**

原位	第一转位	第二转位	第三转位
<b>Cdim7</b>	<b>°Edim7</b>	<b>°Gdim7</b>	<b>A°dim7</b>

在吉他指板中，一个小三度音程相当于三个琴格的长度，所以，任何一个减和弦的指型都能够在纸板上上下的移动，也就是说，每个指型在指板上均可得到四种同音异名的减和弦。

**Cdim = °Eaug = °Gaug = A°dim**  
**#Cdim = Eaug = Gaug = °Gdim**  
**Ddim = Faug = °Aaug = Bdim**

### 减和弦在指板上的位置

根音在第六弦之可移动和弦	根音在第五弦之可移动和弦	根音在第四弦之可移动和弦

### 使用时机

减和弦最常出现在任意的二个和弦之间，用来做为连接二个和弦之间的桥梁，好比说，和弦进行是D-G-A-Gm你可以加入一些减和弦，让它的进行变成D#Fdim-G°Bdim-A-Gm，就漂亮多了。这是最常用的方式，以下一个和弦为参考依据，加入比它少一个半音的减七和弦，流行歌里比比皆是，太多这种用法了。





Am  $\sharp Fm7$   $\sharp Fm7$  B7sus4 E

2 1 2 1 2 3 2 2 1 6 6 · 3 3 1 2 2 — 0 0 1 3 — — 1

没有 任 何 的 疑 问 这 是 爱 我 猜 你

Am E Am E

4 3 4 3 4 5 3 3 2 3 3 — 0 1 4 3 4 3 4 5 3 3 2 3 2 1 1 — 0 1

早 就 想 要 说 明 白 我 觉 得 自 己 好 失 败 从

Am  $\sharp Fm7$   $\sharp Fm7$  B Am7

2 1 2 1 2 3 2 2 1 6 6 · 3 3 1 2 2 3 2 2 · 5 7 6 · 5 5 4 4 3

天 堂 掉 落 到 深 渊 多 无 奈 嘿 我 愿 意 改 变

E Am7 E Am7

3 — — 0 5 6 6 5 5 4 5 5 5 3 2 1 — 0 5 1 1 7 7 6 6 5

重 新 再 来 一 遍 我 无 法 只 是 普

E  $\sharp Cm7$  A B7sus4 B7

5 3 2 2 1 · 5 6 1 1 6 1 5 5 | 3 3 3 3 3 · 4 3 2 — 0 5 5 5

通 朋 友 感 情 已 那 么 深 叫 我 怎 么 能 放 手 但 你 说



E  $\sharp Gm7$   $\sharp Fm7$   $Bsus4$  B

3 — — 0 1 | 2 2 2 2 2 3 1 | 1 6 1 6 | 6 5 5 4 3 2 . 5

I I on-ly want to be your friend 做个朋友 我

E  $\sharp Gm7$   $\sharp Gm7$   $Gm7$   $\sharp Fm7$   $Bsus4$  B

3 4 3 4 3 2 1 1 1 | 2 2 2 1 5 3 2 | 2 3 2 1 1 6 1 3 | 3 4 3 2 2 . 5

在 你 心中 只是 just a friend 不是情人 我

$bDm7-5$   $bA7$   $\sharp Cm7$   $\sharp Fm7$

6 6 6 6 6 6 6 6 | 6 6 6 6 6 7 7 3 | 1 7 1 7 7 6 7 1 | 1 7 1 7 6 5 3 0 5

感谢 你对 我 这样 的坦 白 但 我给你的 爱暂时 收不回来 so

$\sharp Fm7$   $B7sus4$  E  $Am7$

3 — — — — | 2 2 2 2 2 3 2 | 1 . 5 3 2 3 2 1 | 6 7 6 5 6 2 2 . 2 2

I 我不能只是 be your friend I just can't be

E  $Am7$   $\sharp Fm7$   $B7sus4$

3 1 1 5 3 2 3 | 4 — — 0 5 | 3 — — 0 1 | 2 2 2 1 2

your friend 我 I 我 不能 只是 be

E Am7 E

2 — — — 3 2 1 · 5 3 2 3 2 1 | 6 7 6 5 6 2 2 · 2 2 3 1 1 2 3 4 · 3 3 2 1

your friend ————— I just can't be your friend

Am7 E Am7 E

2 — — — 1 2 · 1 5 6 5 — — — 0 · 5 1 2 3 5 4 3 2 1 2 3 — — — 0 3 5 1

No ————— 不能只是做你的朋友

Am7 E9

2 | 1 2 1 6 4 2 1 1 — — — 1 — — —

不能做普通朋友 Fine



# 国王的新歌

词/武雄 曲/游鸿明 演唱/张鸿明



$\flat E$

Key



D

Play



1

Capo



4/4, = 70

Tempo



Slow Soul

Rhythm

D      $\sharp Fdim7$  4fr.      $A dim7$  4fr.     G     C9      $\sharp Fm7$  2fr.     Bm7 2fr.

0 2 3 2 5 3 7 8 10 12     4 4 4 4     5 4 3 2 1 0     0 0 3 2 3 2 1 0     5 2 2 2 2 2 2 2     5 3 2 3

(Free Tempo)

Em 7fr.     Bmaj7 chord diagram"/>  $\flat Bmaj7$  5fr.     Bmaj7/E chord diagram"/>  $\flat Bmaj7/E$      A13-9 chord diagram"/> A13-9

0 0 4 5 7 6 3 1     0 3 0 1 1 1 1 1     1 1 7 -

D      $\sharp Fdim7$  4fr.     G     B chord diagram"/>  $\flat B$      D/A chord diagram"/> D/A     #Fm/B chord diagram"/>  $\sharp Fm/B$  2fr.     Gm/C chord diagram"/> Gm/C 3fr.     Gm/A chord diagram"/> Gm/A 3fr.

3 2 3 5 6 6 5 5     1 2 3 1 6 6     5 6 1 2 3 5 6 5     1 - - -

我用一支吉 他     为你写情歌     一段旋律想甲半 眠     半







Bm 2fr. Bm 2fr. A G Em7 3fr. A D A#C 2fr.

1 6 1 1 — — | 6 5 6 3 3 — | 6 3 6 5 5 — | 5 3 3 5 2 3 2 1 3 |

如雨下 记得把他 把他带回家 他们也说情歌最可怕

Bm 2fr. Bm 2fr. A G A D A#C G/B D/A D A#C 2tr.

3 2 1 1 — — | 6 5 5 1 2 1 2 5 | 3 3 3 — — | 5 3 3 5 5 3 5 2 1 |

不懂的人只会看笑话 爱过的人你要忍痛

(GT.1伴奏同副歌)

Bm 2fr. Bm 2fr. A G D#F Em7 3fr. A 4fr. 5fr. D D/C

1 6 1 1 — — | 6 5 6 3 3 — | 6 5 6 3 3 2 1 | 5 — 5 6 5 4 3 4

咬紧牙 闭上眼睛 跟我一起 唱吧 (GT.2 Solo)

G/B A#C 2fr. G/B A#C 2fr. bB/D 3fr. C/E 5fr. D A#C G/B D/A

3 1 5 5 2 1 1 6 5 7 1 2 | 6 6 7 6 5 5 — | 6 7 1 1 7 2 2 7 6 | 6 — —

Em7 3fr. A A13-9 D #Fm7-5 G #Fm 2fr.

3 4 4 5 5 4 3 2 1 2 | 2 — — — :| 1 — — — | 6 5 6 3 3 —

吧 闭上眼睛



Em7      A      D      #Fm/#C      C      Bm9      Em7

6 5 6 3 3 2 1      1 — — —      0 2 3 2 5 3 5 3      0 6 5 6 0 3 2 1 2      0 0 0 0

跟我一起      唱      吧      呜      耶

A9      A13-9

0 0 0 0      0 5 1 7 2 1 3 4 6 5 5 — — —

Fine



# Guitar 47 双吉他的伴奏

所谓“双吉他”，意指两把以上的吉他同时弹奏。有鉴于音乐的演奏形态趋于复杂，或是在某些即兴演奏的场合下，使用一把吉他是无法演奏出比较多变的音乐风格，所以这时候我们使用双吉他来做搭配演奏。

## 一、使高低音程错开的方式

以下是Aphrodites Child的名曲“Rain and Tears”中的前奏部份改编而成的双吉他演奏谱，像这种加入一把弹奏简化和弦，而将高低音程错开的方式为最多也最常使用的一种方式。这种演奏方式，可让音乐演奏的感觉变的更宽广。另一方面，由于简化和弦易弹奏，可以使演奏变化上更趋于丰富。

The image displays a guitar score for two guitars. The top staff shows a sequence of chords: C, G, Am, Em, F, C, D7, G. The bottom staff shows a sequence of chords: C, G, Am, Em, F, C, D7. Each chord is accompanied by a fretboard diagram and a rhythmic notation with 'x' marks indicating fretted notes. The bottom staff includes fret numbers like 12fr., 10fr., 8fr., 7fr., 5fr., 3fr., and 7fr.



## 二、使用移调夹来做把位的变换

谱例中，我们列举了在 Jim Grose 的名曲 “These Dreams” 中的前奏部份。这是将二把调性不同的吉他，藉由移调夹 (Capo) 的使用，将二者的调性调成一样来做演奏的方式。谱例中，一把吉他弹奏 D 小调 (Dm)，另一把吉他则可移调夹夹住第五琴格而变成 D 小调，弹奏 A 小调 (Am) 和弦，这么一来，二者都成为 D 小调的演奏了。这种的演奏方式，可得到富于变化的对位演奏型式。

### Guitar1 Play Dm

Diagram illustrating the first guitar part (Guitar 1) playing Dm. The notation shows four chords: Dm, Dm/C, Gm $\flat$ B, and Gm6, followed by a melodic line with a capo on the 5th fret and a final Dm chord. The fretboard diagrams show the chord shapes for each chord.

### Guitar2 Capo:5 Play Am

Diagram illustrating the second guitar part (Guitar 2) with a capo on the 5th fret, playing Am. The notation shows Am, Am/F, and Am chords, followed by a melodic line with a capo on the 5th fret. The fretboard diagrams show the chord shapes for each chord.

Diagram illustrating the continuation of the second guitar part (Guitar 2) with a capo on the 5th fret, playing Gm $\flat$ B, Gm6, and A7sus4 chords, followed by a melodic line with a capo on the 5th fret. The fretboard diagrams show the chord shapes for each chord.

Diagram illustrating the continuation of the second guitar part (Guitar 2) with a capo on the 5th fret, playing Dm and E7sus4 chords, followed by a melodic line with a capo on the 5th fret. The fretboard diagrams show the chord shapes for each chord.



### 三、在即兴演奏的场合下使用

通常在单吉他的演奏上，遇到比较多音或是做即兴演奏都无法得到良好的编奏。这时候最好的方式，便是做成双吉他的演奏。其实，即兴演奏并不是有很熟练的技巧就可以表现得很好，这是一种除了技巧之外还需要靠 Felling 来弹奏的方式，而这种 Felling 必须要靠你平常接触的音乐中去体会揣摩而来，每个人都可能不一样，当然除了 Felling 要够好之外，手上的技术更是不可缺的工具。以下的练习是将杜德伟翻唱的“Hello”与原唱-莱诺李奇的“Hello”的间奏，做双吉他的重新编奏。

The score is divided into three systems, each with a guitar part and a bass line. The guitar part includes chord diagrams and fretting patterns.

**System 1:**

- Chords: Am9 (5fr.), Am9/G (5fr.), Am/F (3fr.), Am9 (5fr.), Am9/G (5fr.).
- Fretting patterns: 7, 2, 0 1 3, 0 1 3, 1 3 0 0, 2 3 5 3, 3 5 5, 7, 8 5 7, 8 5.

**System 2:**

- Chords: Am/F (3fr.), Am9 (5fr.), Am9/G (5fr.), Am/F (3fr.), Am9 (5fr.), Am9/G (5fr.).
- Fretting patterns: 3 5 3 5 3 5 1, 3 5 3, 0, 12, 12 12, 10, 12 10, 8 7, 8, 10 10 8 10, 3 5 5, 7, 8 5 7, 8 5.

**System 3:**

- Fretting patterns: 3 5 3 5 3 5 1, 3 5 3, 0, 12, 12 12, 10, 12 10, 8 7, 8, 10 10 8 10, 3 5 5, 7, 8 5 7, 8 5.



# 双手的温柔

词/秋元康、姚谦 曲/见岳章 演唱/江美琪



G



G



4/4 = 80



Slow Soul

G



D/#F



F



Am7



GT.1

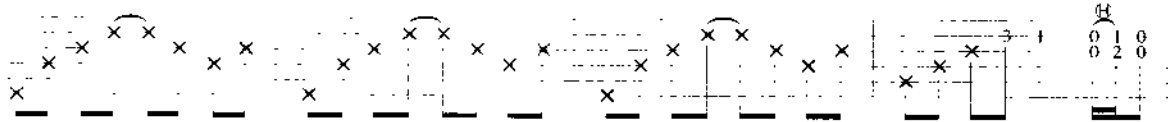

GT.2

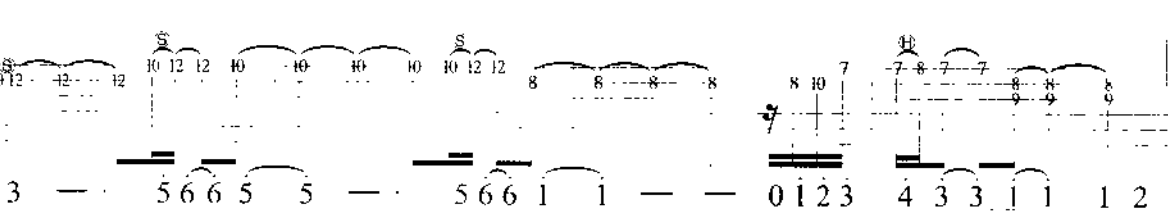

先别

Gadd9



Em7sus4



C



Bm7



Am7



Am7 D

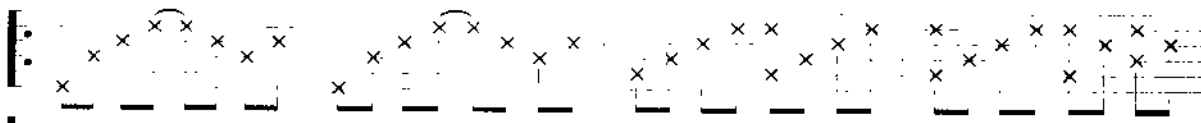

3 2 3 5 1 2  
说先别说离开  
后多年后也许

3 2 3 1 1 2  
我的理由反正  
不再伤痛当我

3 5 1 7 5 3  
都将是相同的  
们已经失去了

0 3 2 1 2  
结果拥抱  
联络可能

Gadd9



Em7sus4



C



D



G



3 2 3 5 1 2  
着拥抱着没开  
你可能我在不

3 2 3 6 6  
泪先流落因  
的角落依

5 6 5 3 2 3  
为我学习着放  
旧吹着同一阵

3 1 1 0 1  
手风 偶



Fm9                      Bmsus4                      Cmaj7                      Bmsus4

x x x x x x x x x x x x x x x x  
 x ————— x ————— x ————— x ————— x —————  
 1̣ 6 5 3 5 5 5 ———— 3 5 6 6 1̣ 6 5 3 3 5 5 ————  
 尔 抬 头 看 天 空 心 还 会 有 一 阵 阵 难 过

C                      bEdim7                      Am                      G                      C                      Dadd9

x x x x x x x x x x x x x x x x  
 x ————— x ————— x ————— x ————— x ————— x —————  
 6 1 2 2 1 1 1 7 ———— 6 7 1 2 ———— 2 1 3 4 3 2 2 ———— 5  
 当 我 习 惯 寂 寞 才 是 自 由 的 时 候 啊

G                      Gmaj7                      G7                      Bm                      Bm                      Bm                      bBm

x x x x x x x x x x x x x x x x  
 x ————— x ————— x ————— x ————— x ————— x ————— x —————  
 3 ———— 0 1 2 3 5 3 2 1 7 3 3 ———— 0 0 3 5  
 哈 眼 泪 安 安 静 静 地 流 过 相 爱

Am7                      C                      Cm                      Am7                      Dadd9

x x x x x x x x x x x x x x x x  
 x ————— x ————— x ————— x ————— x ————— x —————  
 4 3 6 6 ———— 5 5 3 3 2 2 3 2 1 3 2 1 3 3 2 2 ———— 5  
 的 时 候 你 说 过 的 话 还 清 晰 在 耳 朵 啊

G                      Gmaj7                      G7                      Bm7                      Bm7                      Bm7                      bBm7

x x x x x x x x x x x x x x x x  
 x ————— x ————— x ————— x ————— x ————— x ————— x —————  
 3 ———— 0 1 2 3 5 3 2 1 7 3 3 ———— 0 0 3 5  
 哈 时 光 安 安 静 静 地 走 过 偶 尔



Am7



4 3 6 6 —

回 过 头

C



5 5 3 3 2 2 3

曾 经 拥 抱 过 的

Cm



2 1 1 — —

双 手

D7

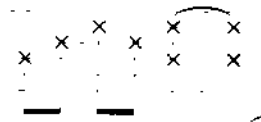

0 4 3 7 2

还 留 着 温

D

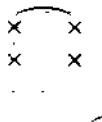

Gadd9

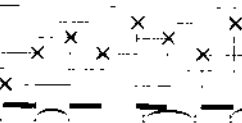

2 1 1 6 6 5 5 —

柔

GT.2 同 Intro

D/F#

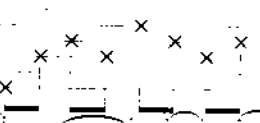

5 6 6 1 1 — —

F



1 — — 0 1 2 3

Am7

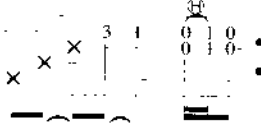

4 3 3 1 1 5 1 2 :|

多 年

柔

2.

bE

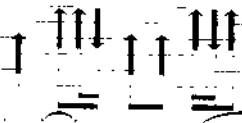

2 1 1 — —

柔

D

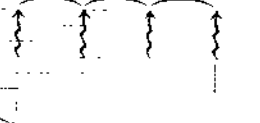

1 — — 5

啊

G



3 — — —

哈

Gmaj7



0 1 2 3 5 3 2 1

G7

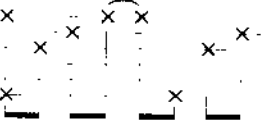

时 间 安 安 静 静 地

Bm7



7 3 3 —

走 过

Bm7

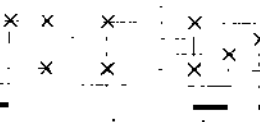

0 0 3 5

偶 尔

bBm7

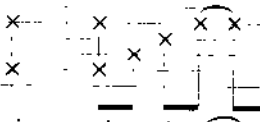

4 3 6 6 —

回 过 头

Am7



5 5 3 3 2 2 3

曾 经 拥 抱 过 的

Cm



2 1 1 — —

双 手

Dadd9



0 4 3 7 2

还 留 着 温

G



2 1 1 — —

柔

C

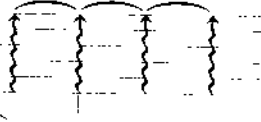

1 — — —

Fine





# Now And Forever

Richard Marx



**Key**  
G



**Play**  
G



**Tempo**  
4/4

G



G



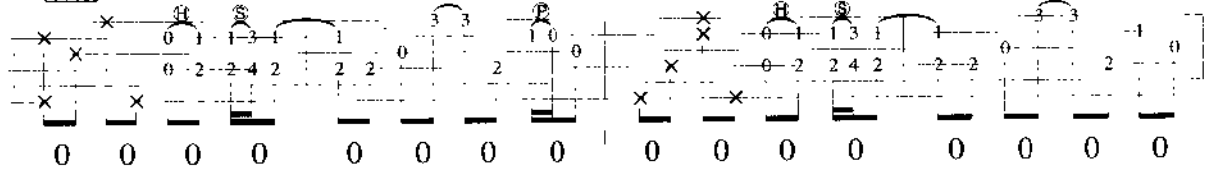



G



D#F



Em



Am



G



D#F



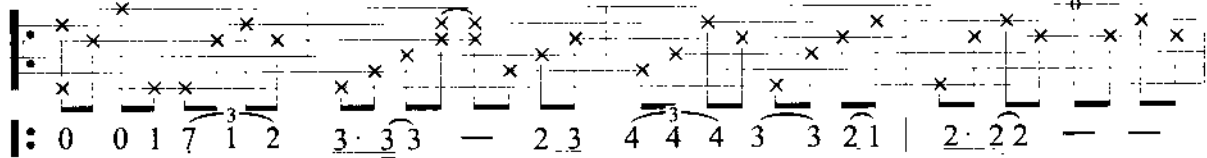

Whenever I'm weary From the battles that rage in my head  
Sometimes I just hold you Too caught up in me to see

G



D#F



Em



Am



G



D#F



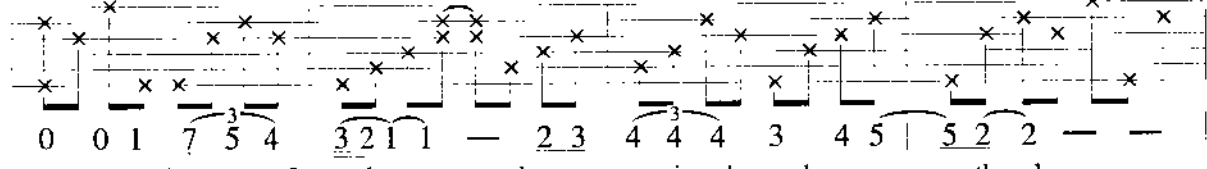

You make sense of madness when my sa-ni-ty hangs by a thread  
I'm holding a fortune that heaven has given to me



C B7 Em D Em/C 2fr

0 0 6 6 6 b6 b6 b6 6 6 7 7 1 1 7 6 6 5 5 3 3 2 1 1 1 2 3 6

I lose my way But still you seem to un-derstand Now and fore-  
 I'll try to show you each and Every way I can Now and fore-

Am7 Dsus4 D G

6 1 1 - - 0 4 3 5 5 2 3 2 2 3 2 1 1 - - 0 0 0 0 :

-ver I will be your man  
 -ver I will be your

G B7 Em C G D

3 2 1 1 - - 1 - 3 3 2 3 2 1 1 6 6 6 0 5 5 4 3 2 2 2 -

man Now I can rest my worries and always be sure

Em C G D/F Em C G D

0 1 1 6 6 6 5 5 1 7 6 5 - 0 1 1 6 6 6 5 5 4 3 2 2 2 3 2 1

That I won't be alone a-ny- more If I'd on-ly know you were there all the time

Am7 G Cm G D/F Em

1 - 0 6 1 3 3 - 2 - 1 1 2 1 7 1 2 2 3 3 3 - 3 4 2 3

All the time

**Guitar2**  
 (classical guitar solo)

5 5 5 7 5 4 5 7 7 9 9 9 9 9 10 7 9



Am G D G D/F Em

4 4 4 5 4 3 1 2 — 0 5 6 7 1 2 3 5 3 · 1 1 · 3 2 · 7 7 7 1 7 6 · 3 3 3 4 3 3 4 4 3 2

10 10 10 12 10 9 5 — 7 — 7 — 5 7 4 5 7 4 7 4 4 2 5 12 12 12 13 12 12 13 12 10

Am G D/F C B7

10-12 8 8 7 7 8 8 8 7 8 10 10 10 8 7 8 7 9 7 5 4 5 5 5 5 5 5

2 3 1 1 · 5 5 1 1 1 · 5 1 2 2 — 0 1 7 1 7 6 5 4 2 | 3 4 4 — 6 6 6 6 6 6 6 6 7 7 1

Until the day the ocean Doesn't

Em D Em/C Am7 Dsus4 D

1 7 6 6 5 5 3 2 1 1 1 2 3 2 2 1 1 — — 0 4 3 5 5 2 3 2 3

touch the sand Now and fore-ver I will be your man

G Am D

3 2 1 1 — — 1 — 1 2 3 4 4 3 2 1 — — 0 4 3 2 2 —

Now and fore-ver I will be

D C Cm G B

your man Rit.....

G

Fine



### 和弦琶音练习 C→D

2 1 3 3 3 1 4 1 3 3 3 1 2 2 2 1 3 3 3 1 4 1 3 3 3 1 2 2

3 2 5 5 3 8 3 5 5 5 2 3 3 5 4 7 7 5 10 5 7 7 7 4 5 5

和弦根音 和弦根音

注：1 2 3 4 表手指代号，可依次选择任意琴格来作练习。



# Hotel California

Eagles



Bm



Bm



4/4 = 72

**Bm9** 7cr.

**A/B** 5fr.

0 0 0 0 0 0 0 0 0 0 0 0 0 0 0 0

(Free Tempo)

**Em** 7cr.

0 0 0 0 0 0 0 0 0 0 0 0 0 0 0 0

0 0 0 0 0 0 0 0 0 0 0 0 0 0 0 0



(Percussion enter 5 Bars)

8 7 6 7 9 10 9 10 12 14 14 14 14

0 0 0 0 0 0 0 0 0 0 0 0 0 0

Bm9 A/B

Bm9 7fr. A/B 5fr.

7 5 7 9 7 7 7 7 7 7 9 7 9 9 9 9 7 7 9 7 6 6 6 7 7 9

0 0 0 0 0 0 0 0 0 0 0 0 0 0 0 0 0 0

Em #F7

Em 7fr. #F7 8fr.

0 0 0 0 0 0 7 0 0 10 12 10 10 9 9 10 9 7 9 7 6 6 3 3 7 8 7 7 8 7

0 0 0 0 0 0 0 0 0 0 0 0 0 0 0 0 0 0

Bm #F7/A A E/#G

Bm 7fr. #F7/A 7fr. A 7fr. E/#G 7fr.

7 9 7 8 10 9

0 0 0 0 0 0 0 0 0 0 0 0 0 0 0 0 0 0

(Guitar1 Simile)

G D/#F Em #F7

G 7fr. D/#F 7fr. Em 7fr. #F7 7fr.

7 9 10 9

0 0 0 0 0 0 0 0 0 0 0 0 0 0 0 0 0 0

(Guitar2)



**Bm** **#F** **A** **E**

(Guitar1 Simile)

(Guitar3)

(Guitar4)

**G** **D** **Em7** **#F**

**Bm** **#F7/#A** **A** **E**

0 2 3 3 2 2 2 2 3 3    0 2 3 3 2 2 2 —    0 2 3 3 2 2 2 2 2 3 3    0 3 3 3 2 2 2 1 6

On a dark des-ert high-way    cool wind in my hair    warm smell of co-li-tas    ris-ing up thru the air  
Her mind is tif-fa-ny twist-ed    she got the Mer-ce-des benz    oh she got a lot of pret-ty pret-ty boys    that she calls friends









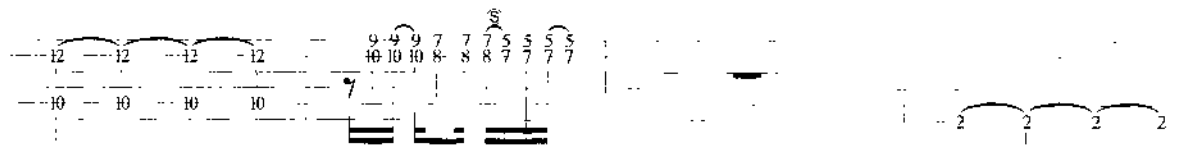

  
 3 4 4 4 4 4 4 4 4 5 4 4 3 3 — — 0 2 3 3 2 2 2 2 2 3 3 2 2 2 2 2 4 | 4 3 3 3 3 — —
   
 plen-ty of room at the Ho-tel cal-for-nia an- y time of year any time of year you can find it here

  
 12 12 12 12 9-4 9 7 7 7 5 5 5 5 10 10 10 8 8 8 7 7 7 7 7 2 2 2 2

  
 0 3 3 3 4 3 4 2 3 3 | 0 3 3 3 3 3 2 2 3 5 6 6 | 0 3 2 2 2 3 2 2 2 2 3 3 | 0 2 3 3 2 1 1 —
   
 Mir-rors on the ceil-ing the pink cham-pag neonice and she socid We are all just pris-on-ers here of our own de-vice

  
 0 1 3 3 3 3 2 1 2 3 3 | 0 3 3 2 2 1 1 — | 0 2 2 2 2 1 1 2 1 2 3 2 1 | 3 3 3 3 2 2 3 —
   
 And in the mas-ter's cham-bers run-ning for the door They stab with their stee-ly knives it but they just can't kill the beast

  
 0 3 3 4 3 4 2 3 0 1 6 | 6 3 3 3 3 2 2 3 — | 0 5 2 2 2 2 2 2 3 3 3 3 | 3 3 3 2 1 2 2 1 6 6 |
   
 Lost thing I re-mem-ber I was run-ning for the door I had to find the pas-sage back to the place I was be-fore







# 小小的太阳

词/十一郎 曲/张宇 演唱/张宇



D



C



2



4/4, = 66



Slow Soul

F C/E Dm C F C/E

1214 131313131210121212108 10 10108 78 88 108 8101010+08 668-88-5 75

0 0 0 5 6 1 4 4 4 4 3 2 3 3 3 3 2 1 2 . 2 2 1 7 1 . 1 1 6 5 6 6 6 6 5 4 5 5 5 3 2 1

Dm G C Am

57 5 7 6 7 1 7 9 8 6 7 6 7 7 3 5 3 5 3 3 1 2 0

2 1 6 5 6 1 2 3 5 3 2 1 2 — 5 6 5 3 5 0 1 2 3 2 3 2 3 5 3 3 . 3 2 3 2 2 1 1 0 0 3 5

我在大雨刚停的夜晚 一个人游 荡 经过

F C F C G/B Am

6 5 6 5 6 1 6 6 . 6 6 6 3 3 5 . — 0 0 3 5 6 5 6 5 6 1 6 6 . 1 1 1 6 5 . 3 3 3 2 1 —

一个又一个橱窗只想等天 亮

面对 就要失去的爱情有一点释怀 有 一点旁 徨





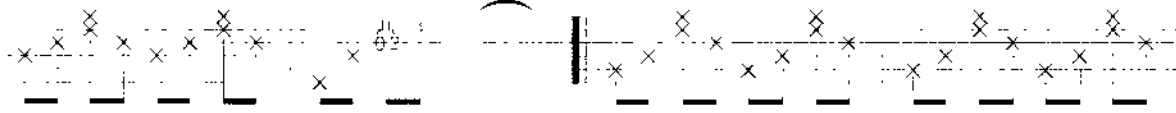

0 · 2 2 2 · 2 2 1 6 2 2 — 0 0 1 2 | 3 2 3 2 3 5 3 3 2 3 2 2 1 1 0 0 3 5

最怕的 其实是孤单 你像 一个小小的太阳有一种温 暖 总是



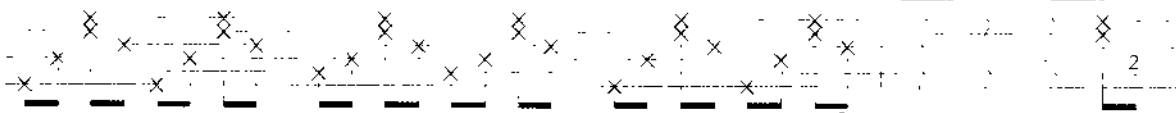

6 5 6 5 6 6 1 6 6 · 6 6 6 3 3 5 · 0 0 3 5 6 5 6 5 1 6 6 · 1 1 1 6 | 5 · 3 3 3 2 1 —

让我将要冰冷的心有地方取暖 我是多么习惯地向你 要一点友善 和 许多依 赖





0 · 2 2 2 · 3 3 2 2 1 1 — 0 1 7 6 · 5 3 6 5 · 3 5 6 5 6 5 3 2 3 3 0 3 2 |

修补我 脆弱的情 感 你总 是微笑如花 总是 看我沉醉和绝望 我却





1 1 · 1 7 5 5 3 6 · 5 6 5 6 2 2 — 0 5 6 1 | 3 3 3 3 2 1 3 3 3 3 2 1

迟 迟 都 没 发 现 真 爱 原 来 在 身 旁 你 应 该 被 呵 护 被 珍 惜 被 认 真 被 深 爱

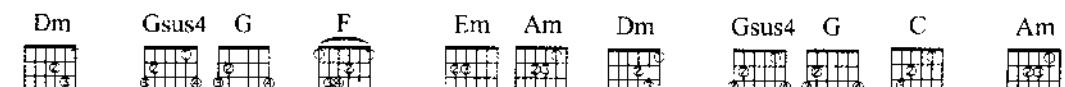



2 2 3 2 1 6 5 — 1 1 1 1 1 5 3 3 3 2 1 2 2 2 3 2 1 6 2 2 5 6 1 | 3 3 3 3 2 1 3 3 3 3 2 1

被 捧 在 手 掌 心 上 像 一 艘 从 来 都 不 曾 靠 岸 的 船 终 于 有 了 你 的 港 湾 你 应 该 更 自 私 更 贪 心 更 坚 持 更 明 白



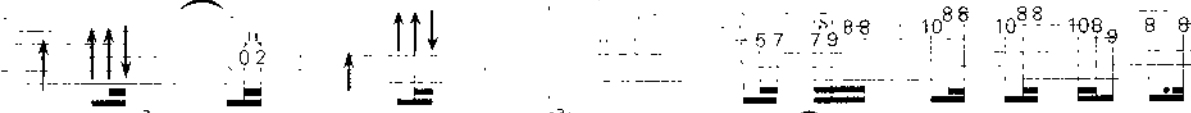

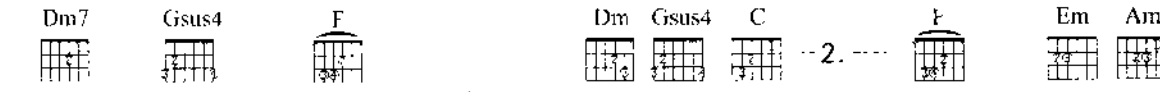
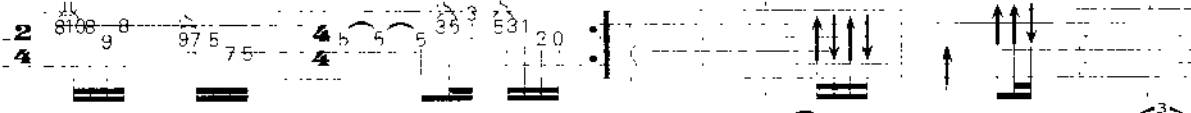
Dm Gsus4 F Em Am Dm G C 1. F Em Am  

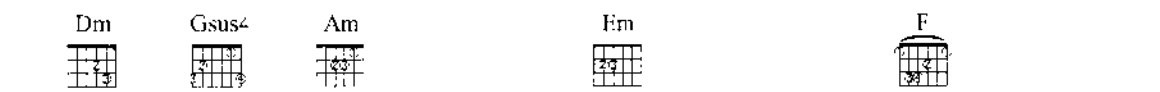
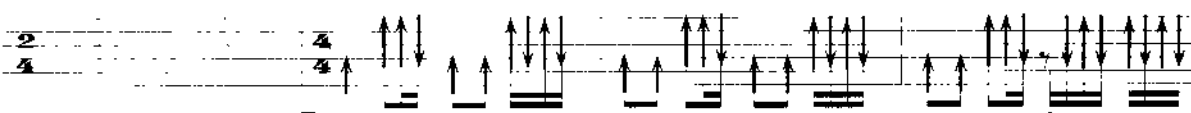

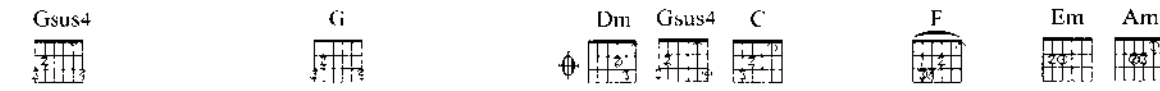
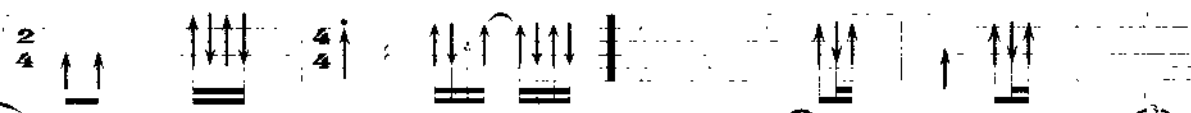
  
 2 2 2 3 2 1 6 5 — 1 1 1 1 1 1 5 3 3 3 2 1 2 2 2 3 2 1 1 — 6 5 1 1 6 1 1 6 5 3 5 · 5  
 将我的心全部霸占 你给我从来不奢望回报的爱 让我好好地对待

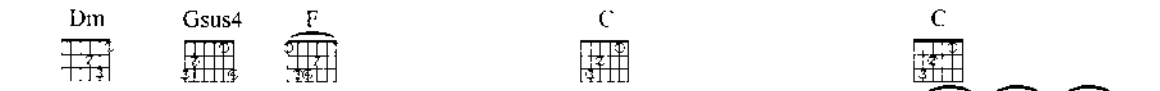
Dm7 Gsus4 F Dm Gsus4 C 2. F Em Am  

  

  
 2 6 5 3 5 2 1 6 5 4 1 — — 0 1 2 : 2 2 2 3 2 1 1 — 1 1 1 1 1 1 5 3 3 3 2 1  
 你像 让我好好地对待 你给我从来不奢望回报的爱

Dm Gsus4 Am Em F  

  

  
 2 2 2 2 3 2 1 1 4 1 — — 1 5 5 — — 0 1 6 1 2 3 3 5 5 3 5 6 5  
 让我好好的对待 呜呜..... Na.....

Gsus4 G Dm Gsus4 C F Em Am  

  

  
 2 5 — 4 5 — — 0 5 6 1 2 2 2 3 2 1 1 — 1 1 1 1 1 1 5 3 3 3 2 1  
 Na 啊 你应该让我好好的对待 你给我从来不奢望回报的爱

Dm Gsus4 F C C  

  

  
 2 2 2 2 3 2 1 1 1 — 0 0 0 0 0 0 1 — — —  
 让我好好的对待 6 1 5 1 6 1 5 1 5 1 7 1 5 1 7 1 6 7 1 3 6 7 5 1 6 5 4 3 5 3 2 1  
 Rit ... Fine







# Guitar 48 和弦的外音修饰

笔者很多中级班的学生，学了很多指型的和弦，甚至是许多高难度的和弦，但大多英雄无用武之地，不知如何来应用。有鉴于此，从本章开始，将一连串地为大家介绍和弦使用的时机，包括外音的修饰、代理与连结...等等，希望能启发大家的灵感，突破吉他的瓶颈。





## 一、加九和弦的修饰 $X_{add9} = X + \text{大九度音程}$

在任意的三和弦上可以使用加九和弦来修饰

原和弦进行

	D	G	A	Bm
				
$\frac{4}{4}$	/ / / /	/ / / /	/ / / /	/ / / /





修饰后和弦进行

	Dadd9	Gadd9	Aadd9	Bmadd9
				
$\frac{4}{4}$	/ / / /	/ / / /	/ / / /	/ / / /







## 二、挂留和弦的修饰 $X_{sus4} = \text{主音} + \text{完全四度} + \text{大二度}$

在任意的和弦上皆可使用挂留和弦来修饰

原和弦进行

	C	F	G	C
				
$\frac{4}{4}$	/ / / /	/ / / /	/ / / /	/ / / /

修饰后和弦进行

	C	Csus4	F	Fsus4	G	Gsus4	C
							
$\frac{4}{4}$	/ / / /	/ / / /	/ / / /	/ / / /	/ / / /	/ / / /	/ / / /



### 三、六和弦的修饰

$X6 = X + \text{大六度音程}$

在任意的三和弦上可以使用六和弦来修饰

原和弦进行

A                      A                      A                       $\sharp Fm$

$\frac{4}{4}$  | / / / / / / / / | / / / / / / / / | / / / / / / / / | / / / / / / / /

修饰后和弦进行

A                      Amaj7                      A6                       $\sharp Fm$

$\frac{4}{4}$  || / / / / / / / / | / / / / / / / / | / / / / / / / / | / / / / / / / /

### 四、延伸和弦的修饰

$X9 = X7 + \text{大九度音程}$

遇到七和弦，可以使用延伸和弦（9和弦、11和弦或13和弦）来修饰

原和弦进行

Dm7                      G7                      Em7                      Am

$\frac{4}{4}$  || / / / / / / / / | / / / / / / / / | / / / / / / / / | / / / / / / / /

修饰后和弦进行

Dm7                      G13                      G11                      Em7                      Am7                      Edim7

$\frac{4}{4}$  | / / / / / / / / | / / / / / / / / | / / / / / / / / | / / / / / / / / | / / / / / / / /





# 梦一场

词/袁惟仁 曲/袁惟仁 演唱/那英



D

Key



C

Play



2

Capo

4/4  $\text{♩} = 54$ 

Tempo



Slow Soul

Rhythm

Cadd9



Cadd9



Am69



Am69

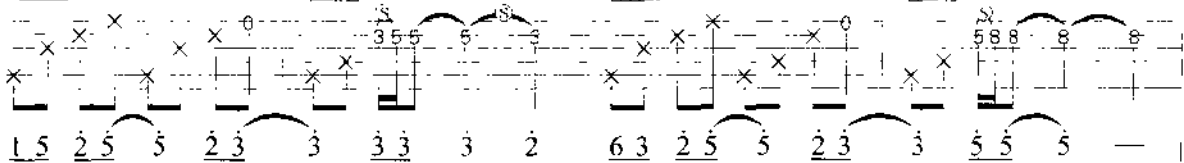

Dm7



F/C



G



Gsus4



G

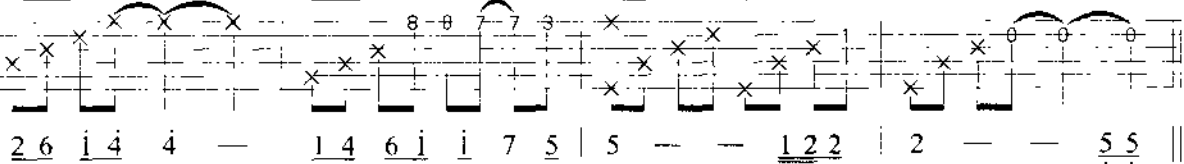

我们

Csus2



C



Csus2



Am7(11)



Am7(11)

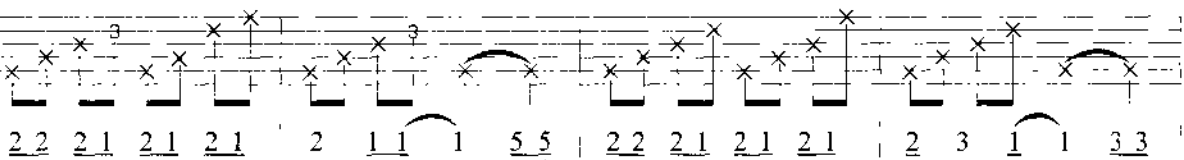

都曾经寂寞而给对方承诺 我们都因为折磨而厌倦了生活 只是



弹指之间

Dm7 F/C Fm/C G

4 3 1 1 6 6 4 3 1 1 6 6 1 — 1 6 5 5 — — —

这样的日子 同样的方式 还要多久

G Csus2 C C Am7(11)

0 0 0 5 5 2 2 2 1 2 1 2 1 2 1 1 1 5 5 2 2 2 1 2 1 2 1

我们 改变了态度而接纳 了对方 我们 委屈了自己成全谁

Am Dm7 F/C Fm/C

2 5 1 1 3 3 5 4 4 3 1 5 4 4 3 1 1 1 — 1 5 1

的梦想 只是 这样的日子 还剩下多少 已 不重要

Cadd9 Cadd9 Em Am7

1 — — — ; 0 0 0 3 4 : 5 5 5 5 5 7 1 1 — — 3 4

时常 想起过去的温存 它让



Em Am Dm7 F/C

5 5 5 5 5 6 1 1 — — 3 3 4 3 1 1 1 1 1 6 6 1 1 — 1 1

我在夜里不会冷 你说 一个人的美丽是认真 两个

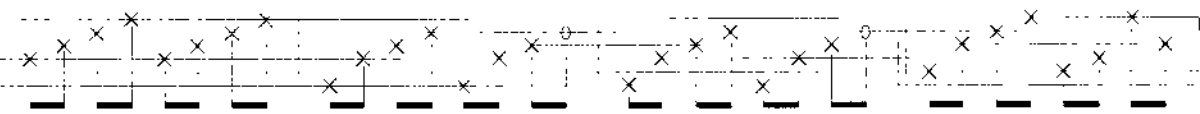

F<sub>sus2</sub> F G<sub>sus4</sub> G<sub>sus4</sub> Cadd9  
  
  
 5 4 3 4 3 1 6 6 2 2 — — 0 0 0 3 3 4 || 5 3 3 5 5 · 5  
 人能在一起是缘分 早知道是这样像

G<sub>sus4</sub> Am7 Em7 F  
  
  
 5 3 3 2 2 1 1 1 7 6 7 6 5 5 3 6 5 3 5 5 · 5 5 4 3 4 4 · 4  
 梦一场我再不会把爱都放在同一个地方我能原谅你

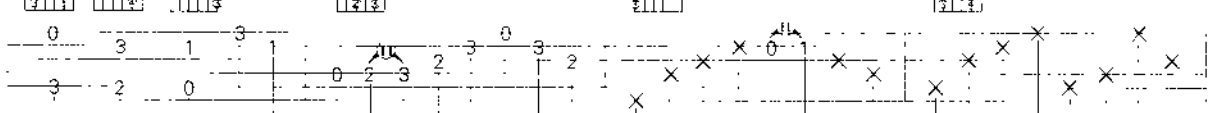
C Em/B Am7 F6 G<sub>sus4</sub> Cadd9  
  
  
 3 2 1 1 6 1 2 2 2 3 2 3 2 6 2 — 0 3 3 4 5 3 3 5 5 · 5  
 的荒唐荒唐的是我没有办法遗忘早知道是这样如

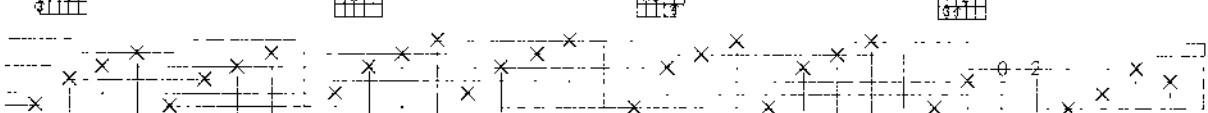
G<sub>sus4</sub> Am7 Em7 F  
  
  
 5 3 3 2 2 1 1 1 7 6 7 6 5 5 3 6 5 3 5 5 · 5 5 4 3 4 4 · 4  
 梦一场我又何必把泪都锁在自己的眼眶让你去疯让

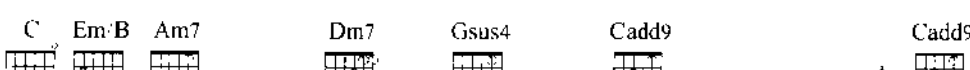
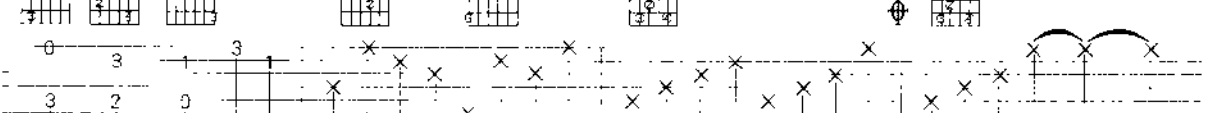
C Em/B Am7 Dm7 G<sub>sus4</sub> Cadd9 Cadd9  
  
  
 3 2 1 1 6 1 4 3 1 4 3 1 6 2 1 — — 0 0 0 0  
 你去狂让你在没有我的地方坚强



Cadd9      C      Am7      Am7

1 5 2 5 1 5 3 3 | 3 2 5 5 | 5 5 | 5 — — 0 1 | 1 7 5 5 5

Dm7      F/C      G      Gsus4      G

2 6 1 5 1 3 5 3 | 2 · 1 1 6 | 2 — — 0 2 | 5 — 0 3 4

时常

C      Dm7      Dm7/G      Dm7/G      Csus2      C

0 0 0 6 1 | 4 3 1 4 3 1 | 2 4 | · 6 | 1 — — —

让我 在没 有你 的地 方

忧 伤

Rit ...

C      Am(11)      Am7(11)      Dm7

0 · 3 3 2 1 | 2 — — — 0 · 3 3 2 1 | 6 2 2 2 —

F/C      G6sus4

0 · 1 4 3 1 2 | 5 6 1 5 4 1 6 | 0 0 0 0 |

Fine



# 她他

词/徐若瑄 曲/SUGIZO 演唱/徐若瑄

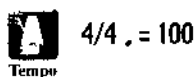

Cmaj7



Am9



1 5 7 1 1 — 1 5 7 1 1 — 6 5 7 1 1 — 6 5 7 1 1 —

Fmaj7



Gsus4



C



4 4 3 6 6 — 5 5 1 7 7 — 1 5 7 1 1 5 7 1 1 — — 5 |

他

Cmaj7



Am9



5 — 0 4 3 4 5 6 6 0 5 | 5 — 0 4 3 2 2 3 3 0 5 |

他 他 深深爱 着她 他 他 永远的 吗 他 他 轻轻吻 着她 他 他 弹着吉 他 他



Fmaj7



Gsus4



Cmaj7



5 — 1 2 3 3 3 2 2 2 4      4 3 3 — — 0 0 0 5

他 送 她 玫 瑰 花 的 和 吉 他 她  
他 最 爱 摸 她 的 长 头 发 她

Cmaj7



Am9



5 — 0 4 3 4 5 6 6 — 5      5 — 0 4 3 2 2 3 3 0 5

她 也 深 爱 着 他 她 她 她 不 变 的 吗 她  
她 看 着 那 个 他 她 爱 听 他 弹 吉 他 她

Fmaj7



Gsus4



Am9



Am9/G



5 — 1 2 3 3 3 2 2 2 4      4 3 3 3 4 4 3 3 3 1 7 1

她 收 到 的 玫 瑰 花 已 枯 萎 了 呢 枯 萎 了 他 和 她  
她 寂 寞 的 小 世 界 被 他 溶 化 慢 慢 溶 化 他 和 她

Fmaj7



Gsus4



Am9



Am9/G



1 — 6 7 1 1 1 7 5 5 4      3 6 6 6 — 0 0 0 1 7 1

爱 很 美 浪 漫 就 多 像 到 玫 瑰 花 他 和 她  
爱 的 Me-lo - dy 多 到 挤 不 下 他 和 她

Fmaj7



Gsus4



Am9







Am9/G



1 — 6 7 1 1 1 7 5 5 4      4 3 3 3 4 4 3 3 3 1 7 1





爱 很 难 很 小 心 也 不 一 定 留 得 住 它 他 和 她  
人 随 时 也 可 能 没 有 明 天 不 要 害 怕 她 和 他







1 — 6 7 1 1 | 1 — 7 7 — | 2 — 7 1 2 2 | 2 1 5 5 3 3 4

有时候可 怕 静 静地死去 它 不 挣 扎  
 让灵魂自 由 着 见爱与被 爱 在 打 架











4 — 0 0 5 — 7 — || 1 — — 0 | 3 — 4 —





(算了吧) 不 说 (她和他) 话 (笛)

5 — — — 5 — 6 — | 3 — — — | 3 — 4 —

5 — — — 5 — — — | 2 1 7 1 5 — — | 0 4 3 2 2 3 3 —

7 1 2 7 1 2 | 7 1 2 7 1 2 | 3 5 5 6 5 5 | 5 — 7 —



Cmaj7 Cmaj7 Fmaj7 Gsus4

2 — — — 1 — — — 5 :| 1 — 6 7 1 1 | 1 7 5 5 4

他 话 爱 很 美 浪 漫 就 像

Am9 Am9/G Fmaj7 Gsus4

3 6 6 6 — 0 0 0 1 7 1 1 — 6 7 1 1 | 1 7 5 5 4

玫 瑰 花 他 和 她 爱 很 难 很 小 心 也

Am9 Am9/G Fmaj7 G

4 3 3 3 4 4 5 5 5 1 7 1 1 — 6 7 1 1 | 1 7 7 —

不 一 定 留 得 住 它 他 和 她 有 时 候 可 怕

Em Am Am9/G Fmaj7 Gsus4 G

2 — 7 1 2 2 | 2 1 7 7 1 6 6 — 0 0 5 — 7 —

静 静 地 死 去 它 不 挣 扎 不 说

Cmaj7 Am9

1 — — — :| 0 0 0 0 | 0 0 0 0 | 0 0 0 5

话 他





**Fmaj7** **Gsus4** **C** **Cmaj7**  
 5 — 1 2 3 3 3 2 2 1 7 1 1 — 0 0 0 0 0 0 0 0  
 他 送 她 Ro - se & Gui - tar Rit.... Fine



### 小七和弦琶音练习 Am7

1 4 3 1 3 1 1 4 1 4 1 4 1 1 3 1 3 4 1  
 5 8 5 8 5 8 5 8 5 7 5 7 8 5  
 5 8 7 5 7 5 5 8 5 8 5 5 7 5 7 8 5  
 和弦根音

注：1 2 3 4 表手指代号。可依次选择任意琴格来作练习。



# 我可以抱你吗

词/小虫 曲/小虫 演唱/张惠妹



D



D



4/4, = 68



Slow Soul

D9



G



Aadd9



D9



Aadd9



Bm7

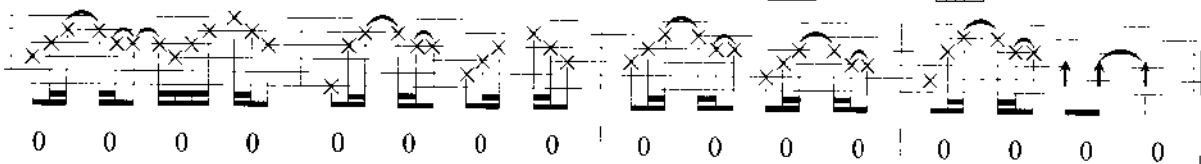

Acoustic guitar appoggio

D9



Bm7



G



Em



Aadd9

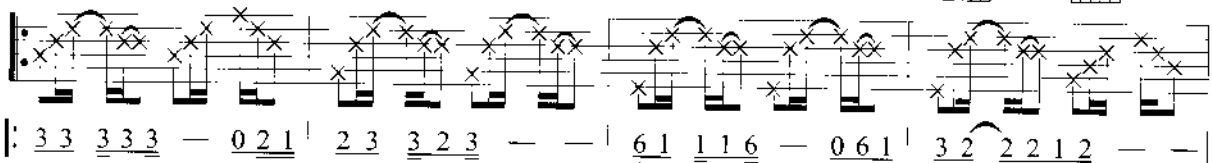

外面下着雨

犹如

我心 血在滴

爱你那么久

其实

算算 不容易

D9



Bm7



G



Em



Aadd9

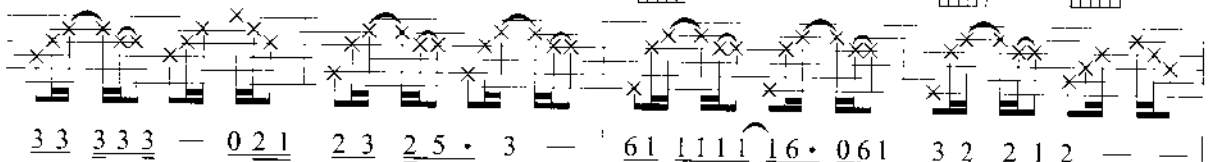

就要分东西

明天

不再 有 关 系

留在家里的衣服

有空

再来 拿回去



Gmaj7    #Fm 2fr.    Bm 2fr.    Gmaj7    #Fm 2fr.    Bm 2fr.    Em

0 3 2 1 2 2 3 7 5 6 6 0 6 1 6 5 4 3 4 3 | 0 3 2 1 2 2 3 7 5 6 | 6 0 6 1 6 2 2 1 2 3 3

不去想爱 都 结了果 舍不得拼命找借口 不勉强你 再为了我 心不在留不留都是痛

A    D9    Bm7 2fr.    Em7    Bm7 2fr.    #Fm 2fr.

2 — — — 5 5 5 5 5 5 6 6 1 . | 2 2 2 1 2 3 2 2 1 6 0 3 5 | 6 5 5 5 5 3 6 5 5 3 2 1

我可以抱你吗爱人 让我在你肩膀哭泣 如果 今天我们就要分离让我

Em    Aadd9    D9    Bm7 2fr.    Em    Bm7 2fr.    #Fm 2fr.

2 2 2 1 6 3 3 2 2 — 5 5 5 5 5 5 6 6 1 . — 2 2 2 2 2 2 3 2 1 6 0 3 5 | 6 5 5 5 3 5 6 5 3 2 1

痛快地哭出声 音 我可以抱你吗宝 贝 容我最后一次这样叫你你也 不得已 我会笑笑地 离

D9    Gmaj7    #Fm 2fr.    Bm 2fr.

1 — — — | — — — Drum Filt — — — 0 3 2 1 2 2 3 7 5 6 | 6 0 6 1 6 5 4 3 4 3 |

去

Gmaj7    #Fm 2fr.    Bm 2fr.    Gmaj7    #Fm 2fr.    Bm 2fr.

3 — 0 3 2 . 1 | 2 1 . 6 2 3 3 5 3 3 3 2 1 2 2 1 6 1 . 6 | 0 3 2 1 2 2 3 7 5 6 | 6 0 6 1 6 5 4 3 4 3 |



Gmaj7    F#m    Bm

3 · 6 — 7 · 5 5 2 · 2 — — —

D9    G    Aadd9    Gmaj7    F#m

1 — — 0 3 5 | 6 5 5 5 3 5 6 5 3 2 1 | 1 — — 1 | 1 3 2 1 2 2 3 7 5 6

去                      你也 不得已 我会笑笑的                      离 去

Rit ...

Bm    Gmaj7    F#m    Bm    Gmaj7    F#m

6 0 6 1 6 5 4 3 4 3 | 3 — — — — — 0 0 0 3 2 1 2 2 3 7 5 6

Bm    Gmaj7    F#m    Bm

6 0 6 1 6 5 4 3 4 3 | 3 — — — — — 0 0

Fade out





G D9#F Bm7 Asus4 D Bm7 D9#F G D

6 3 2 1 6 6 5 5 3 2 1 1 — 0 2 3 5 1 1 3 5 5 0 3 5 1 1 1 6 3 5 5 0 3 2

反正你远得看不见 可是才一转眼过了再度单身的新鲜 一思

Bm7 Bm7/A G D9#F Em7 Asus4 G D9#F Em9 D

1 1 1 1 1 1 6 6 6 6 5 3 2 — — 3 5 1 1 3 5 5 0 3 5 1 1 1 6 3 5 5 0 3 2

一想一言一笑没人分享也无味 才快乐几天寂寞偷偷在心底作祟 原来

Bm7 G D9#F Em7 A7sus4 D G69 D G69

1 1 1 1 1 1 6 6 6 5 5 3 2 2 — 0 0 1 2 3 2 1 1 6 1 1 1 0 1 2 3 2 1 1 3 5 5

思念会让分离感觉像度日如年 还是情愿你留在身边 还是情愿你掌管一切

D9#F Bm7 Bm7/A G D9#F Em7 Asus4 D D G69

5 0 3 5 6 6 5 5 3 2 1 6 6 3 2 1 6 6 5 5 3 2 1 1 — — 3 5 6 1 1 6 1 1 2 1 1 2 0 0 5 6 1

情愿有你胡闹或斗嘴 嘿嘿 嘿嘿 是我肺腑之言 **Flute**

D G69 D9#F Bm7 Bm7/A G D9#F Em7 Asus4 D

2 1 1 3 5 6 5 5 6 0 0 1 7 5 5 5 3 6 5 5 6 3 2 1 7 3 4 3 2 1 1 3 5 6 1 2 3 2 1 1 — 0 2 3 5

可是才



Bm7 2fr. #Fm 2fr. G D Bm7 2fr. Bm7/A G D9/#F Em7 A7sus4

1 1 3 5 5 0 3 5 | 1 1 1 1 6 3 5 5 0 3 2 | 1 1 1 1 1 6 6 6 6 5 3 2 — — 3 5 |

一 转眼 过了 再度单身的新鲜 一思一想一言一笑没人分享也无味 才快

G D9/#F Em9 2fr. D Bm7 2fr. G D/#F Em7

1 1 3 5 5 0 3 5 | 1 1 1 1 6 3 5 5 0 3 2 | 1 1 1 1 1 6 6 6 6 5 5 3 | 2 4 3 2 2

乐 几天 寂寞 偷偷在心底作祟 原来思念会让分离感觉像度日 如年

A D G6/9 D G6/9 D9/#F Bm7 Bm7/A

4/4 0 0 0 0 | 0 1 2 3 2 1 1 6 1 1 | 1 0 1 2 3 2 1 1 3 5 5 | 5 0 3 5 3 6 5 5 3 2 1 6 |

还是情愿你留在身边 还是情愿你掌管一切 情愿有你胡闹或斗嘴

G D9/#F Em7 Asus4 D G D9/#F Em9 A

6 3 2 1 6 6 5 5 3 2 1 | 1 — — 0 | 0 3 2 1 6 6 — | 2 4 0 0

嘿 嘿嘿 是我肺腑之言 嘿 嘿嘿 (A. G)

D

4/4 0 0 0 0 | 0 0 0 0 | 0 0 0 0 | 0 0 0 0 |

Rit ... Fine





Am D G Em9 Bm7 Em9 Bm7

3 2 2 2 2 2 0 5 5 6 1 6 1 1 — — 3 5 5 | 1 1 3 5 5 0 3 5 | 1 · 1 1 3 5 5 0 3 2 |

的积蓄 买了门票一对 我唱得 她 心醉 我唱 得 她 心醉 三年  
听电话 夜夜听歌不睡 成年

Am Bm7 Dsus4 C Dsus4 Am Bm Am Bm

1 1 1 1 · 1 7 6 6 5 3 3 2 — 0 · 3 2 3 2 3 2 3 3 2 3 5 5 · 3 | 2 3 2 3 2 3 2 2 3 5 5 |

的感情 一封信就要收回 她记得月台汽笛声声在催拨 我的歌陪着人们流泪  
人分手 后都像无所谓 和 朋友一起买醉卡拉OK唱 我的歌陪着人们流泪

Am7 Dsus4 G Am7 Dsus4

0 6 5 6 1 · 0 5 6 6 1 3 | 3 2 1 1 — 0 0 0 0 | 0 6 5 6 1 · 0 5 6 6 1 3 |

嘿 嘿 陪人们流 泪 嘿 嘿 陪着流眼

Gadd69 Am C G G/B

3 2 1 1 — 0 5 · 1 7 1 3 7 6 2 7 5 4 3 2 1 2 3 4 3 1 5 5 3 1 2 | 3 2 3 3 4 3 2 1 2 2 3 1 |

泪

Csus4 Dsus4 Gadd69 Em9 Bm7 Em9 Bm7

1 — 0 4 3 4 5 1 3 4 4 6 · 5 3 5 5 | 1 1 3 5 5 0 3 5 | 1 · 1 1 3 5 5 0 3 2 |

我唱得 她 心醉 我唱 得 她 心醉 在三



Am Bm7 Dsus4 C Dsus4 Am Bm Am Bm

1 1 1 | 1 . 1 | 7 6 5 | 5 3 3 | 2 — | 0 . 3 | 2 3 2 3 | 2 3 3 | 2 3 5 | 5 . 3 | 2 3 2 3 | 2 3 3 | 2 3 5 | 5 |

十三岁 真爱那么珍贵 年轻的女孩求她让一让位让男人决定跟谁远走高飞

Am7 Dsus4 G Am7 Dsus4 G

0 6 5 | 6 1 . | 0 5 6 | 6 1 3 | 3 2 1 | 1 — | 3 5 5 | 0 6 5 | 6 1 . | 0 5 6 | 6 1 3 | 3 2 1 | 1 — |

嘿 嘿 谁在 远走 高飞 我唱得 嘿 嘿 唱到 自己 流泪

G C Am7 Dsus4

0 3 3 3 | 3 3 3 | 3 5 1 | 1 — | 0 . 5 | 2 2 2 | 2 2 2 2 | 2 . 1 | 7 7 1 2 | 2 — |

她来听 我的演唱会 在 四十岁后听歌的女人很美

Bm7 Em9 Am7 D G

0 3 5 | 5 5 5 | 5 . 5 | 6 6 5 6 | 6 1 . | 1 — | 0 6 1 | 3 2 2 2 | 2 0 5 5 | 6 1 6 1 | 1 — | 0 6 1 |

小孩在问她为什么流泪 身边的男人 早已渐渐入睡 她静

Am D G

3 2 2 2 | 2 0 5 5 | 6 1 2 1 | 1 — | 0 0 0 0

静听着 我们的演唱会  
Rit... Fine



# 49 和弦的连接与经过和弦

在两个不相同的和弦之间，加入另一个新的和弦，使得前后的两个和弦更为连贯，此一新的和弦称之为「经过和弦」(Passing Chord) 或「过门和弦」。

以下提供几种常用和弦之连结方式：

## 一、以原和弦的属七和弦来连结

原和弦进行

C F G C

4/4

修饰后和弦进行

C C7 F F7 G G7 C

4/4

## 二、以原和弦的小调和弦来连结

当下属和弦进入主和弦时，可使用下属和弦的小调和弦来连结。

原和弦进行

C Am F C

4/4

修饰后和弦进行

C Am F Fm C

4/4



### 三、以下一和弦的逆四度和弦进行来连结

原和弦进行

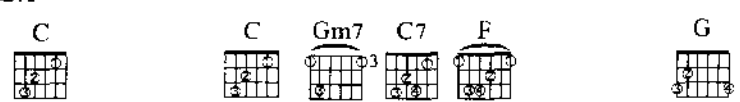

  
 $\frac{4}{4}$  | / / / / | / / / / | / / / / | / / / / |

修饰后和弦进行



  
 $\frac{4}{4}$  | / / / / | / / / / | / / / / | / / / / |

### 四、使用增和弦 (Augmented) 来连结

原和弦进行

  
 $\frac{4}{4}$  | / / / / | / / / / | / / / / | / / / / |

修饰后和弦进行

  
 $\frac{4}{4}$  | / / / / | / / / / | / / / / | / / / / |



## 五、使用减七和弦（Diminished 7）来连结

原和弦进行

A diagram showing a 4/4 time signature with a sequence of four chords: C, Dm7, Em7, and F. Each chord is represented by a guitar fretboard diagram. The C chord is at the 1st fret, Dm7 at the 2nd fret, Em7 at the 3rd fret, and F at the 4th fret. The progression is indicated by a horizontal line with diagonal slashes representing strings, and a vertical bar line separates the first two chords from the last two.

修饰后和弦进行

A diagram showing a 4/4 time signature with a sequence of six chords: C, #Cdim7, Dm7, bEdim7, Em7, and F. Each chord is represented by a guitar fretboard diagram. The #Cdim7 chord is at the 3rd fret and has an 'x' over the 4th string and '3fr' below it. The bEdim7 chord is at the 3rd fret and has 'x' over the 4th and 5th strings. The progression is indicated by a horizontal line with diagonal slashes representing strings, and a vertical bar line separates the first four chords from the last two.



# 离人

词/厉曼婷 曲/何家文 演唱/林志炫



Key



Play



Capo

2



Tempo

4/4 = 90



Rhythm

Slow Soul

Amaj7



Amaj7



#Cm9



4fr.

5 4 5 4 4 | x x x x x | x x x x x | x x x x x |

0 0 1 7 1 7 5 | 3 - - - | 0 0 1 7 1 7 5 | 3 - - - |

(E.P)



#Cm9

4fr.



#Cm/B

2fr.



A



#Fm

2fr.

4 2 4 2 5 | x x x x x | 4 2 4 2 5 | x x x x x |

0 0 3 2 3 2 1 | 6 3 2 3 2 1 | 6 3 2 3 2 3 | 6 5 5 3 3 2 2 1 |

E



Emaj7



2fr.

2 - 6 - | 1 - - - | 0 0 5 6 1 2 | 3 5 5 3 5 5

银色小船 摇摇晃晃



E6 2fr.    Emaj7 2fr.    #Cm 4fr.    #Cm 4fr.    Emaj7 2fr.

3· 55 5 4 3 5 7 1 6 6 — 0 0 5 6 1 2 | 3· 55 3· 55

弯弯 悬在绒绒 的天上 你的心事 三三 两两

E6 2fr.    #Cm 4fr.    #Cm 4fr.    A

3· 55 1 7 7 6 6 5 5 3 2 2 1 1 0 0 0 5 5 5 5 4 4 3 4 6 6

蓝蓝 停在我幽 幽心上 你说情 到深处人怎么不

B/A 2fr.    #Gm7 4fr.    #Cm7 4fr.    E/B

1 7 7 — 5 6 | 7 7 7 1 7 5 3 | 2 1 1 5 6 1 2 3· 55 3· 55

孤单 爱到 浓时就牵肠挂肚 我的行李 孤 孤 单 单

A/B 2fr.    B 2fr.    E 4fr.    E 2fr.    E    A

3· 55 3· 5 5 1 1 — — 0 0 1 7 1 7 1 | 1 — — —

散散 惹 惆 怅 离人放逐到 边

B/A 2fr.    #Gm7 4fr.    #Cm7 4fr.    #Fm7 2fr.

7· 1 7 1 6 7 | 7 6 — 6 5 5 3 | 5 0 5 3 5 3 1 | 6· 3 2 3 2 1

界 仿佛走入第 五 个 季 节 昼夜乱了和 谐 潮泛任性涨



**#Gm7** 4fr. **A** **B** 2fr. **A**

1 5 5 3 2 3 2 3 | 5 — — — — — 5 0 1 7 1 7 1 | 1 — — — — —

退 字典里没春 天 离人挥霍着 眼

**B/A** 2fr. **#Gm7** 4fr. **#Cm7** 4fr. **#Fm7** 2fr.

2. 1 7 1 1 7 | 1 6 6 7 7 6 6 5 0 5 3 5 3 1 | 1 6 0 3 2 3 2 1

泪 回避还 在 眼前 的 离 别 你不敢想 明天 我不肯说再

**#Gm7** 4fr. **A** **B** 2fr. **A** 1.

1 5 0 3 2 3 2 3 | 6 5 5 3 3 2 2 1 | 2 — 1. 6 6 1 1 3 3 3 2 1

见 有人说一次 告别天上就会有颗 星 又 熄 灭 (E.P)

**#Cm9** 4fr. **Cmaj7** 5fr. **A/B** 2fr. **B** 2fr. **#Fm7** 2fr. **#Gm7** 4fr.

7. 1 1 5 | 5. 1 1 3 2 | 1 — 7 — | 4 5 6 1 1 0 5 |

**A** **B7** 2fr. **E** **E** **E** 2.

6 — 1 — | 1 — — — — — | 1 — 5 6 1 2 :| 6 1 1 — — — — —

银色小船 灭





E



6 4 2 2-2-1-2-1 2

1 0 1 7 1 7 1

離入放逐到%

E



#Cm7 4fr.



Cmaj7 3fr.



A/B 2fr.



6 1 1 — 0 3 3 0 0 0 0 5 5 0 0 0 0 0 0 1 6 0 3 2 1 2

灭

Emaj7 2fr.



5 — — — 5 — — —

Fine



# 50 代理和弦

现代音乐的和声中，传统的三和弦已鲜少会被采用，尤其是对一个进阶班的琴友而言，所以在本章中我将介绍一些和弦，来代用原来的和弦，使得和声变得更为刺激，弹奏的Felling可以更好，这类的和弦，我们称之为「代理和弦」。

一般代理的情形，我把它分为以下几种：

## 一、使用原和弦的七和弦来代理：（大七和弦，属七和弦）

原和弦进行

C                      F                      G                      C

4/4

代理后和弦进行

C      Cmaj7      Fmaj7                      G7                      C

4/4

## 二、使用原和弦的六级小七和弦来代理

这是最常用的一种代理方式，因六级小七和弦与原和弦具有相同的组成音，意即  $Dm7 = F/D$  和弦， $Am7 = C/A$ ，不失原和弦特性，只有改变了根音位置。

原和弦进行

C                      F                      G                      C                      A7                      F                      G                      C

4/4

代理后和弦进行

C                      Dm7      G                      Am7      A7                      F                      G                      C

4/4



### 三、使用原和弦的三级小七和弦来代理

原和弦进行

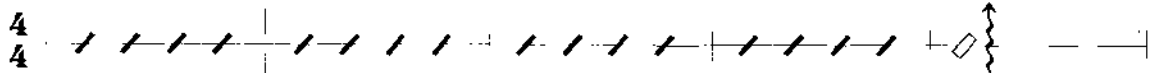
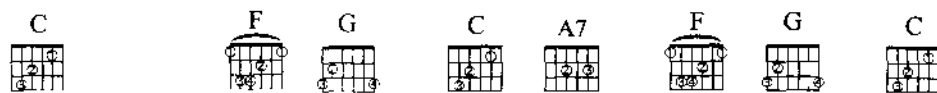

代理后和弦进行

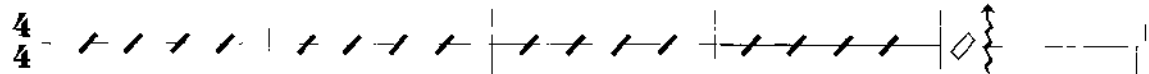
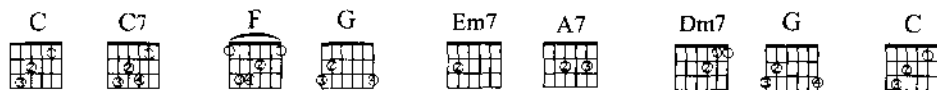

### 四、使用减七和弦来代理

在范例中我们可以使用 $\sharp Cdim7$ 、 $Ddim7$ 、 $Edim7$ 来代用C和弦，但是须注意，使用这类的代用和弦，最好在小节的后半部来代用，换句话说，C和弦至少须弹奏二拍以上。

原和弦进行

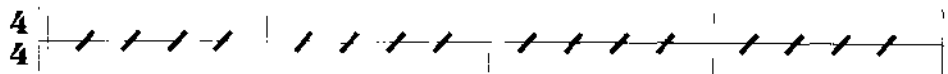
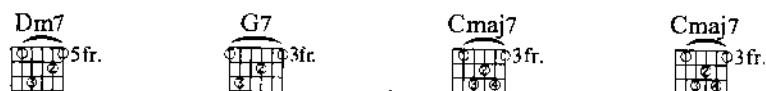

代理后和弦进行

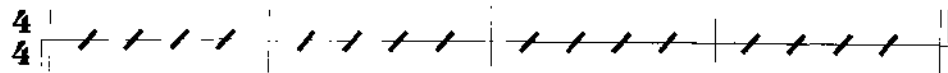
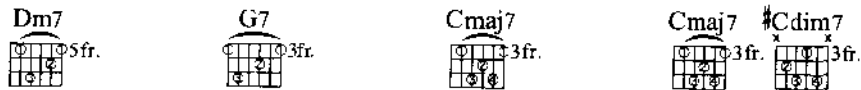



# Guitar 51 浅谈唱片制作

在国内，每年有上百张的唱片推出，相信每张唱片都有其不同的制作过程及制作理念，在此，就自己较熟悉的体系，跟读者聊聊：

一个好的制作物，必须从最原始的来源（词、曲）就要好，然后在接下来的每一个环节，依循着原发的想法去执行：在每项乐器收音时也得仔细地挑选音色，并确认收进来的音质是好的：跟每一个参与工作的人做好沟通、互动....，这些都是很累但也很有趣的工作！

## 制作企划

歌手（ARTIST）“定位”是非常重要的。基本上，歌曲是表现人类情感的一种方式，歌手则扮演着代言人的角色，所以，歌曲形态必须符合歌手的形象，对听众才具说服力，也就是说当制作人（PRODUCER）面对歌手时，必须考虑到“像这样的歌手，要说什么才自然？别人才听得进去？”，于是从他身上找到一些特质加以强化突显，甚至帮歌手设计一个“定位”，将其定位轮廓清晰化。例如大家最熟悉也是最粗略的分法，就是将歌手分成偶像派或实力派两种，一般走偶像路线者，大都具备姣好的外形，诉求之年龄较轻，所以歌曲之设计宜轻快明朗、简单易记；词意力求年轻、明亮、健康、励志。而实力派唱将选歌的方向则偏难度较高，可表现歌唱技巧、音质特色，情绪较满的曲子。

## 词曲收歌

当歌手之定位清楚后，制作人先将大概的版位分配好，即分配各种不同曲风在专辑中之比例，例如歌手若属偶像派，且个性属开朗健康型的，则其轻快版位的歌曲比例可多一点，甚至可作舞曲，抒情曲当然是不可少的菜色之一，过于沧桑悲苦或火爆的曲风可能较不适合。分配好版位之后，再依其曲风找擅长该曲风的词、曲作家（LYRIC WRITER COMPOSER）沟通，同时另外再提供一些资料如歌手之音域（RANGE），那些音域的音色（TONE）是最好听的，以便词曲作者能替歌手量身订做，写出歌手适合的歌曲。



## 编曲过带

当各词曲作家交歌后，制作人汇总所有收到的试听带 (DEMO)，召开选歌会议，决定录用之歌曲后便交给编曲 (ARRANGEMENT) 开始作业。制作人跟编曲之间的沟通，除了用口头叙述外，有时也提供一些参考资料 (REFERENCE)，例如先将想要的风格雏型做成试听带，或从其他唱片上找到风格类似的歌。当然，有时也给编曲很大的想像空间，完全让编曲自由发挥。

目前国内之流行乐编曲，有大部分是使用合成乐器 (音源)，先在自家用电脑或编曲机录制编曲，由一人完成模拟多人乐队编制之效果 (一般我们称此为 MIDI)，编好后再将电脑或编曲机及音源带至录音室，分别将不同之乐器逐一录进多轨 (MULTI TRACK) 盘带之不同轨道里，过程称之为「过带」。

## 搭配乐器(Dubbing)

在 MIDI 乐器部份录好后，另外再录制真实乐器部份。

使用 MIDI 乐器的好处是可做出某些真实乐器无法做出的音色或特殊音效 (如风雨声、雷声)，其拍子 (BEAT) 准确度也比较好，且可在正式录音前不断重复演奏聆听，可将乐句修至最完美为止。但是某些乐器的效果却也是 MIDI 做不出来的。例如：吉他、萨克斯风、口琴、胡琴.....等乐器，因为诸如此类的乐器在演奏时有太多技巧、演奏表情、演奏音色，以及演奏者个人的感觉 (包含乐手 PLAYER 不准的拍子、音量落差、杂音等小瑕疵，只要在正常容许范围里，也是音乐表情的一种)，这些都是 MIDI 所无法取代的，一般而言，吉他、萨克斯琴、口琴、胡琴等乐器还是得由乐手来演奏的。



## 配唱

在乐器部份录制完成后，将歌手声音录进盘带谓之配唱。

配唱可说是整个制作过程中变数最多的一个环节，也是学问最大的部分。首先制作人必须先向歌手描述歌曲的感情、走法。唱歌其实有点像写文章，有抒情文、有应用文、记叙文、还有论说文，更有“起、承、转、合”的表情进行。句子与句子间的承接，都可用不同的唱法、唱腔及不同的共鸣位置来营造情绪的起伏。歌手演唱前除了要先熟悉旋律外，对歌词更是要细细体会，要入戏，就好像在描述自己的故事一般。除了情绪、律动和音乐要一致，同时也要注意咬字清晰、音准的控制。

在制作人与歌手间的互动中，更是需要谋对谋一番，因为影响歌手表现好坏的因素太多了，像是歌手的身体精神状况、信心度，甚至是当天的心情，都会表现在声音当中，或者所演唱的歌是歌手以往所不常接触或不擅长的类型，甚或歌手本身对歌曲的喜恶有很大的主观意识，歌手会下意识地排斥自己比较不喜欢的歌，所以制作人必须在维持歌手信心的前提下，导引歌手进入状况，往往为了某一乐句，反覆的唱超过数十次以上，歌手可能愈唱愈佳，也可能因为反覆太多次而没感觉、沮丧等，所以制作人也必须懂得拿捏歌手的情绪，适可而止，捕捉住最佳的乐句。所以在录音室里也常常听到制作人说心情故事，把歌手弄得伤心欲绝，唱起悲伤的歌就特别感人，或是说笑话，搞的像是来录音室郊游一样，唱起轻快的歌，也就特别有味道，真是连哄带骗的，为的就是录下最好的音乐。

## 和声(Chorus)

在配唱完后依需要请专人编写合声谱，再依曲子的性质决定男声、女声的人数来搭和声。一般搭和声的时候，该注意的是和声的表情应该贴着主旋律，比如像转音的地方应一致，尾音长度要一致，拍子更是要对齐，当然，各声部间的平衡(BALANCE)，比例要对。在录音室常见的编制是由三人唱不同的声部，然后交换声部再搭一次，听起来就得到六个人和唱的效果(或由二人唱，搭三次，亦可得六人之效果)。



## 混音(Mix)

将多轨的音乐处理成二轨立体音 (STEREO) 输出的过程称之为混音。

混音可说是制作过程中最后一个完稿程序，也是决定音乐呈现风貌的程序，其中包括调整BALANCE，即每项乐器之间的音量大小比例，使音乐和协度更好，亦可以让欲表现之乐器被突显；Panpot（相位），即每项乐器之间的左右位置，使听觉上能感受到乐手演奏的位置；EQ (EQUALIZER)，即高频、中频、低频各频率音量之增减，可修掉音乐过于尖锐或油糊的频率；效果器 (EFFECT)，即是针对不同的乐器，加不同的效果而模拟出不同的空间感及回音效果。电脑更可记录每一轨道音量被改变的过程，也就是说混音师可再为每项乐器做表情，例如可帮主唱把某几个念的不是很清楚的字，推大声一点或清楚一些，或是某些该渐弱的尾音，慢慢地拉小，诸如此类的修饰。在混音完成后输出两轨到 DAT（或两轨盘带）做为将来生产 CD 或卡带的母带 (MASTER)。

由于篇幅的关系，无法在此讨论更详细的细节，但还是希望能提供一些经验，让对唱片制作有兴趣的读者朋友，能因此而更接近流行音乐！





# 剪爱

词/林秋离 曲/涂惠源 演唱/张惠妹



F



C



5



4/4, = 66



Slow Soul



C



F/C



C



F/C

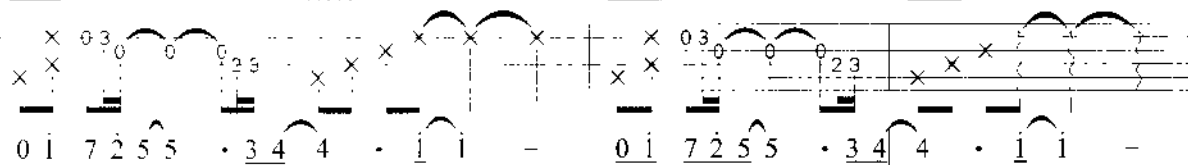

0 1 7 2 5 5 · 3 4 4 · 1 1 - 0 1 7 2 5 5 · 3 4 4 · 1 1 -

Wo.....



Dm-F



Fmaj7



Em7



Em



Am



Fmaj7



Fmaj7

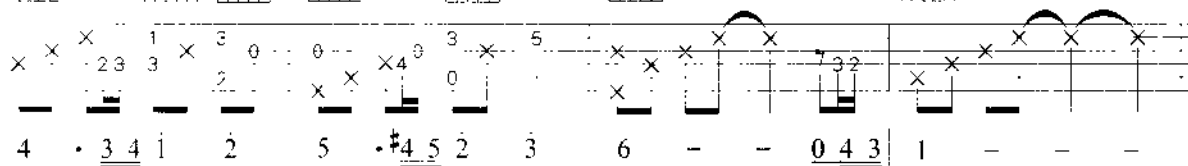

4 · 3 4 1 2 5 · 4 5 2 3 6 - - 0 4 3 | 1 - - - |

Ya..... 喔.....

Ya.....



C



Em7



Am



Am7/G



D9/#F

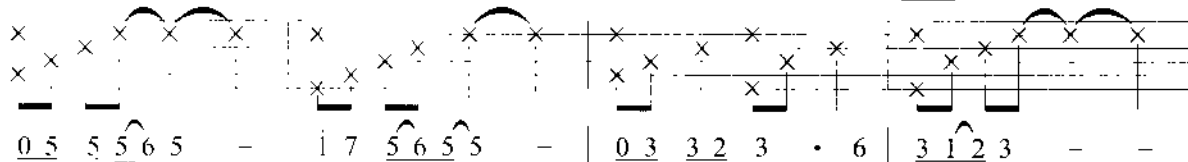

0 5 5 5 6 5 - 1 7 5 6 5 5 - | 0 3 3 2 3 · 6 | 3 1 2 3 - -

人变了心

言而无信

人断了情

无谓伤心

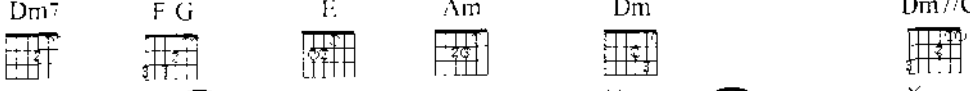
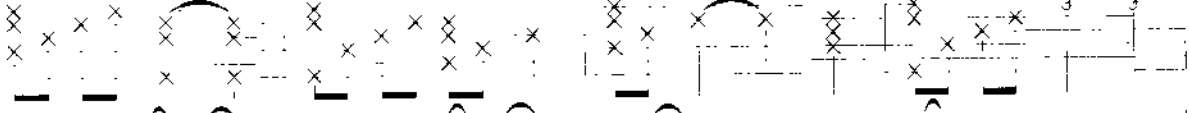

弹指之间

Dm7 F/G E Am Dm Dm7/G  
  
  
 0 4 4 3 5 5 4 4 0 3 3 2 2 2 1 1 3 6 6 6 1 2 2 6 5  
 我一直聆听 我闭上眼睛 不敢 看你的表情

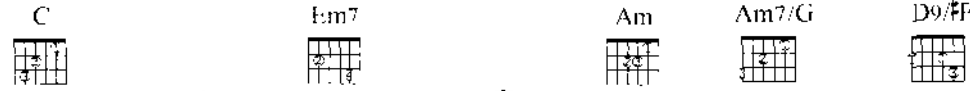
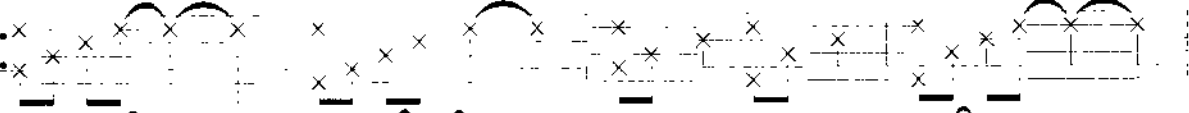
C Em7 Am Am7/G D9/F#  
  
  
 0 5 5 5 6 5 - 1 7 5 6 5 5 - 0 3 3 2 3 6 3 1 2 3  
 满天流星 无穷无尽 我的眼泪 擦不干净

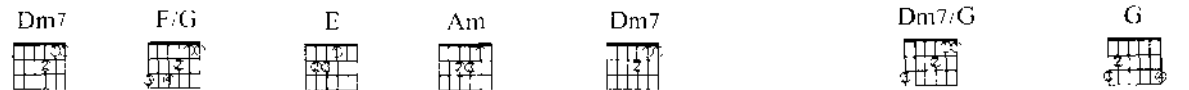
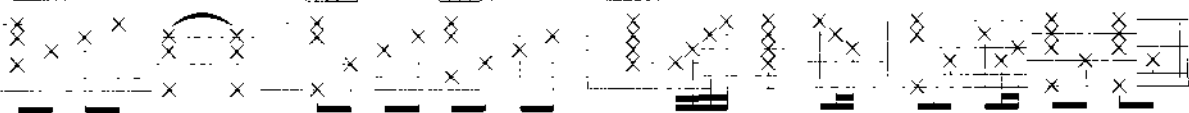
Dm7 F/G E Am Dm7 Dm7/G G  
  
  
 0 4 4 4 3 5 5 4 4 0 3 3 3 2 2 2 1 1 3 6 6 6 3 2 1 3 2 2 2 5  
 所以绝口不提 所以暗自反省 终于 我挣脱了爱情 把

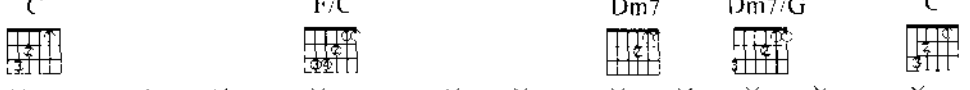
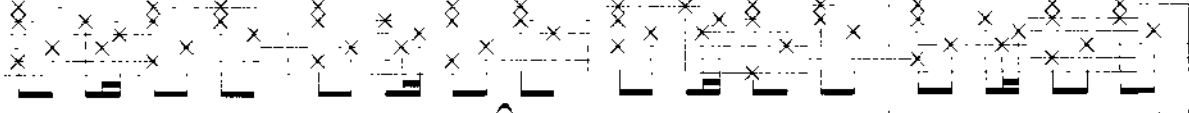
C F/C Dm7 Dm7/G C  
  
  
 3 - 4 3 5 2 2 2 3 2 6 6 6 4 4 4 6 5 4 4 3 3 2 3 1  
 爱 剪碎了 随风吹向大海 有许多事 让泪水 洗过 更明白 天

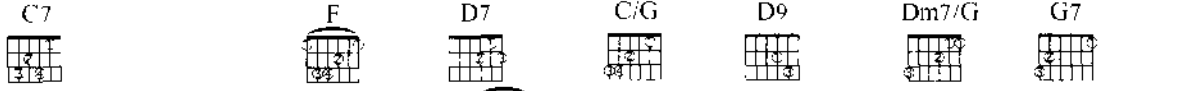
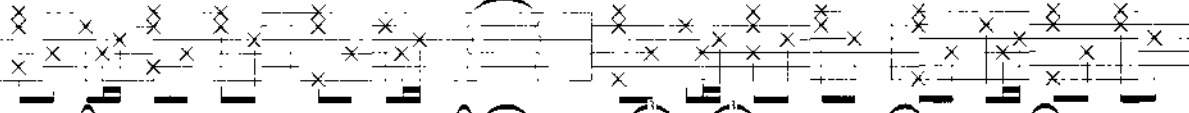
C7 F D7 C/G D9 Dm7/G G7  
  
  
 5 5 5 5 3 4 5 5 4 3 4 4 4 6 6 1 1 5 3 2 1 3 2 1 3 6 3 3 2 1 2 2 5  
 真如我 张开双手以为 撑得住未来 而 谁担保爱永远不 会染上尘埃 把



C F C Dm7 Dm7/G C

3 · 2 1 1 4 3 5 | 2 2 2 3 2 1 1 · 6 | 4 4 4 · 6 5 4 | 4 3 3 2 3 · 1

爱 剪 碎 了 随 风 吹 向 大 海 愈 伤 得 深 愈 明 白 爱 要 放 得 开 是

C7 F D7 C/G Dm7/G C

5 5 5 5 3 4 5 5 4 3 4 4 4 6 6 1 1 · 5 3 2 1 3 2 1 2 2 2 1 7 1 1 7 2 5 5 · 3 4

我 不 该 怎 么 我 会 眷 着 你 眷 成 依 赖 让 浓 情 在 转 眼 间 变 成 了 伤 害

F/C C F/C C Dm7

4 · 1 1 - 0 1 7 2 5 5 · 3 4 4 · 1 1 - : 1 · 2 3 4 · 3 4

害

Em F C Em/B Am Dm7 C/E F

5 3 4 5 1 1 · 5 3 2 1 3 2 1 2 2 2 1 7 6 5 6 1 1 - - | 0 · 3 3 5 3 2 2 2

我 剪 不 碎 旧 日 的 动 人 情 怀 你 看 不 出 来

G7 C F/C C

2 4 2 4 2 4 7 1 7 2 5 5 · 3 4 4 · 1 1 - | 0 1 7 2 5 5 · 3 4

我 的 无 奈



F/C

1	2	3	4
5	6	7	8
9	10	11	12

C

1	2	3	4
5	6	7	8
9	10	11	12

1 1 0 0

Fine





C Cm#D G Em Am7 Cm/G D7

4 6 4 · 4 4 3 2 3 - 3 · 3 3 2 1 2 3 2 1 2 2 1 5 5 2 2 - 0 1 2

不想说 蓝色是忧郁 而飘泊的 你 狂浪的心 停在那里 写信

G Cm/G G Am-5#D G Am-5#D Bm7

2 3 3 3 1 4 4 3 2 1 2 3 3 3 - 0 1 2 2 3 3 3 1 4 4 3 2 1 7 · 5 5 3 5 5 4 3

告诉我 今夜 你想要 梦什么 梦里 外的我 是否 都让你 无从 选择我揪着

C Cm D9/#F Em Am7 D7 G

4 6 4 - 4 3 2 3 5 2 3 1 1 2 3 3 3 4 4 3 2 3 2 3 2 1 1 - - -

一颗心 整夜都 闭不 了眼睛 为何你 明明 动了情 却又不 靠近

G Em Em7 C D7

5 - 5 · 5 2 1 7 1 - - 3 4 5 6 6 6 6 5 5 6 · 6 6 7 1 2 - - -

听 海 哭的声 音 叹息着 谁又被 伤了心 却还不 清醒

Bm7 Em C D7

0 7 7 7 3 5 5 3 7 1 7 1 - 1 2 3 6 1 2 3 6 · 6 3 2 1 2 - - -

一定不是我 至少 我很冷 静 可是泪 水就连 泪水 也都不 相信



G Em Em7 C D7

5 - 5 · 5 2 1 7 | 1 - - 3 4 5 | 6 6 6 6 5 5 6 · 6 6 7 1 | 2 - - -

听 海哭的声 音 这片海 未免也太多情哭泣到天 明

Bm Em Em7 C D7 G Am-5#D

0 7 7 7 3 5 5 3 | 7 1 7 1 - 1 2 3 | 6 6 5 6 7 1 1 · 5 4 3 1 | 2 · 1 1 - -

写封 信给 我 就当 最后约 定 说你在 离开我的时候 是怎 样的 心 情

G Am-5#D G Bm7 C

3 - - - | 3 · 4 5 1 7 - - 7 1 | 6 - 6 7 1 6 |

Bm Em Am7 C C/D Bm

5 · 7 1 - 4 - 5 6 | 1 - 1 1 1 2 | 0 7 7 7 3 5 5 3 |

写信 写封 信给 我 就当

Em Em/D C D7 G A G A

7 1 7 1 - 1 2 3 | 6 6 5 6 7 1 1 5 4 | 3 1 2 · 1 1 - 1 5 5 5 1 5 4 6 |

最后约 定 说你在 离开我的时候 是怎 样的心 情

G



3 4 5

3 4 5

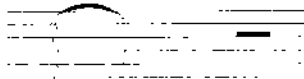

7 - 0 0

Fine





# 光辉岁月

词/黄家驹 曲/黄家驹 演唱/黄家驹



E



C



4



4/4, = 74



Slow Soul

C G Am Em F G

0 0 0 7 1 2 3 4 3 3 2 2 · 1 7 6 6 5 3 2 3 — 0 5 5 6 · 6 1 7 1 7 |

C G C G Am Em F G

1 1 5 1 5 7 1 2 3 4 3 3 2 2 · 1 7 1 7 7 3 2 3 — 0 5 5 6 · 6 2 3 5 6 2 1 |

C G C G Am Em F G

7 1 · 1 — — | : 0 5 5 5 5 5 5 4 3 — 0 3 3 3 7 1 — 0 2 2 1 2 · |

一生要走多远的路 程 经过多少 遍 才能走到









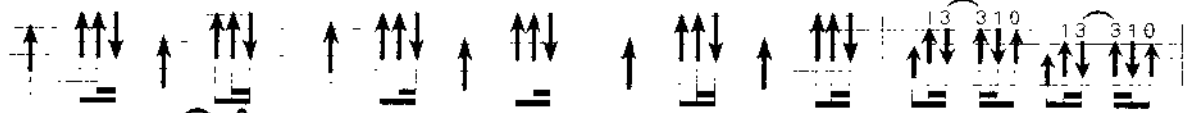



0 3 3 3 1 2 2 4 4 3 1 | 1 · 6 1 3 2 1 7 6 6 | 6 · 6 5 6 5 5 6 | 1 — — 3 2 ·

潮来潮往世界多变 迁 迎接光辉岁 月 为它一生 奉 献 喔





3 2 1 1 — — 0 0 0 0 | 1 1 2 3 3 2 3 | 1 — — —

喔 Fine



和弦琶音练习 G→A

2 1 3 3 2 1 1 1 2 3 3 1 2 2 2 1 3 3 2 1 1 1 2 3 3 1 2 2

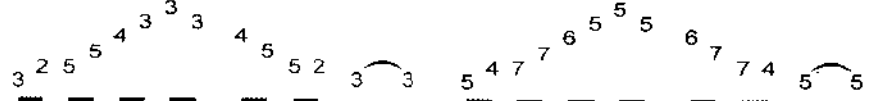

3 2 5 5 4 3 3 3 4 5 5 2 3 3 5 4 7 7 6 5 5 5 6 7 7 4 5 5

← 和弦根音                      ← 和弦根音

注：1 2 3 4 表手指代号，可依次选择任意琴格来作练习



# 能不能不要说

词/阿信 曲/阿信 演唱/五月天



D



D

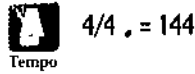

4/4 = 144



Folk Rock

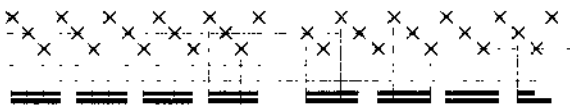
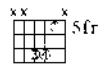

2152 1521 5215 2152 1521 5215 2152 1521 5215 2152 1521

(Syn.)

A



0 0 0 0 ; 7 7 7 7 7 7 7 7

D7



A



D7



D

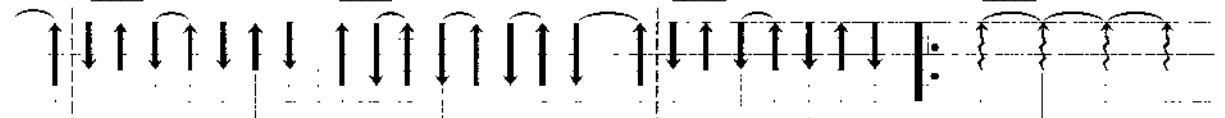

7 b7 b7 — — 7 7 7 7 7 7 7 7 7 b7 b7 — 0 3

昨 天 的 夜 里 我 梦 到  
开 了 那 个 拥 挤 的

Am7



G



A7



D

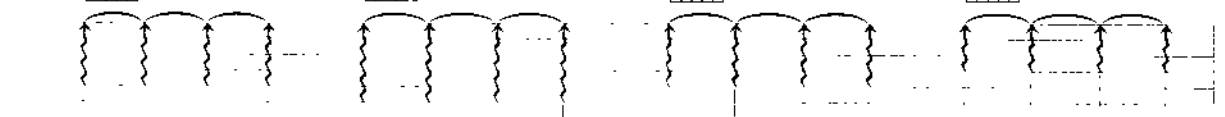

5 2 2 5 5 6 7 1 1 4 4 6 6 5 0 0 0 0 3 5 5 5 5 5 5 3 5

彩 虹 乘 着 船 到 了 尽 头 有 一 个 宝 箱 上 面 刻 着  
星 球 飞 向 那 灿 烂 星 空 回 头 看 昨 天 苦 苦 的



Am7



G



A7

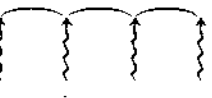

Bm

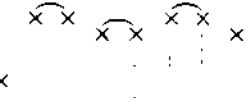

5 2 2 5 5 6 7 1 | 4 4 6 6 5 | 0 0 0 1 2 3 | 3 6 6 3 3

青 春 打 开 了 一 里 面 一 个 空 0 0 0 第 一 次 3 不 不 不 记 记 得 得 得

寂 寞 突 然 间 像 一 个 空 梦 第 一 次 不 不 不 记 记 得 得 得

E

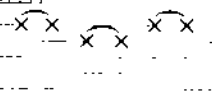

Bm

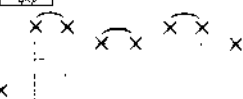

E

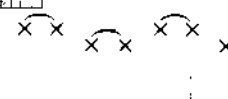

Bm

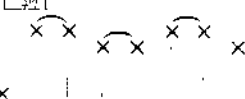

3 2 2 1 6 2 3 5 3 3 2 2 3 3 0 1 2 3 3 6 3 3 3

什 么 什 么 时 候 有 没 有 有 握 握 握 她 她 她 的 的 的 手 手 手 第 一 次 次 次 不 你 不 需 需 需 要 要 要

什 么 什 么 时 候 有 没 有 有 握 握 握 她 她 她 的 的 的 手 手 手 第 一 次 次 次 不 你 不 需 需 需 要 要 要

E



G

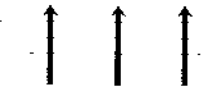

bB6



3 2 2 1 6 0 6 6 7 1 2 3 2 2 1 1 b6 b6 0 0 3 4 4 5

想 得 有 太 多 跟 着 感 觉 走 就 就 不 该 会 给 错 我 能 不 不 能 能 能

想 得 有 太 多 跟 着 感 觉 走 就 就 不 该 会 给 错 我 能 不 不 能 能 能

D

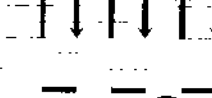

A

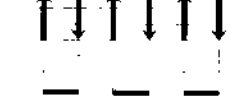

G

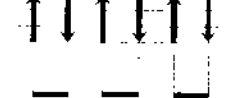

A

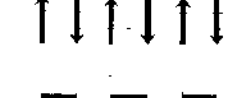

5 - 1 1 1 5 5 - 6 7 7 1 1 7 6 5 5 5 3 4 4 5

不 不 不 要 要 要 说 说 说 你 你 你 想 想 想 要 要 要 的 的 的 是 是 是 什 什 什 么 么 么 能 不 不 能 能 能

不 不 不 要 要 要 说 说 说 你 你 你 想 想 想 要 要 要 的 的 的 是 是 是 什 什 什 么 么 么 能 不 不 能 能 能

D

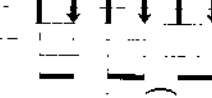

A

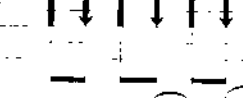

G

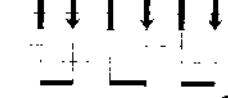

A

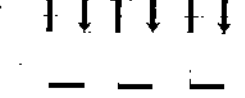









5 - 1 7 7 5 5 - 6 7 7 1 1 7 6 5 5 5 - - -



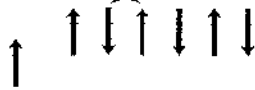
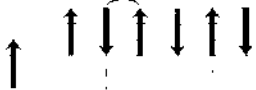
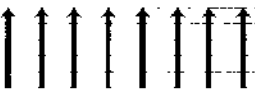

就 就 就 爱 爱 爱 我 我 我 不 不 不 要 要 要 问 问 问 我 我 我 为 为 为 什 什 什 么 么 么 - - -

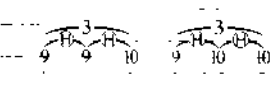
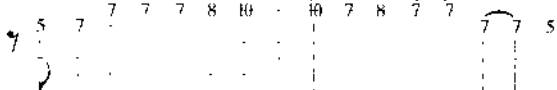
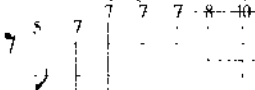



就 就 就 爱 爱 爱 我 我 我 不 不 不 要 要 要 问 问 问 我 我 我 为 为 为 什 什 什 么 么 么 - - -

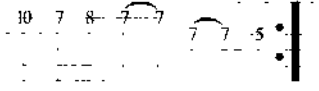
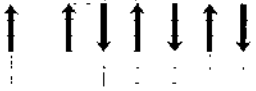





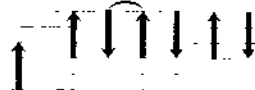
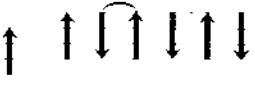
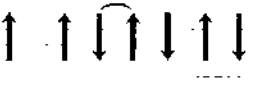
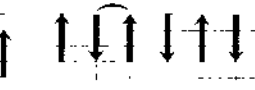

<p><b>Bm</b></p> 	<p><b>E</b></p> 	<p><b>G</b></p> 	<p><b>bB6</b></p> 
			
<p>3 2 1 6</p> <p>十 八 岁 的</p> <p>伊 八 岁 的 里</p>	<p>6 1 6 3 3 6 6</p> <p>第 一 吃 了 啤 啤 苹 酒 酒 果</p>	<p>3 2 2 1 1 6 6</p> <p>火 箭 发 射</p> <p>火 旋 地 转</p>	<p>3 2 2 1 1 b6 b6</p> <p>轰 隆 轰 隆</p> <p>登 陆 月 球</p>
<p><b>G</b></p> 	<p><b>D</b></p> 	<p><b>D</b></p> 	<p><b>D</b></p> 
<p>1.</p> 			
<p>b6</p>	<p>0 b7 1 3 3 3 4 5 5 3 4 3 3 1 1 b7</p>		<p>0 b7 1 3 3 3 4 5</p>

(E.G)

<p><b>bB</b></p> 	<p><b>D</b></p> 	<p><b>A</b></p> 
<p>2.</p> 		
<p>5 3 4 3 3 1 1 b7:   b6</p>	<p>3 4 4 5 5</p>	<p>1 1 1 5 5 6 7 7 1</p>
	<p>能 不 能</p>	<p>不 要 说</p>
		<p>其 实 我</p>

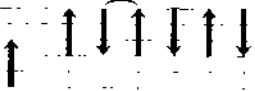
<p><b>G</b></p> 	<p><b>A</b></p> 	<p><b>D</b></p> 	<p><b>A</b></p> 
			
<p>1 7 6 5 5 5</p> <p>不 是 不 懂</p>	<p>3 4 4 5 5</p> <p>能 不 能</p>	<p>1 7 7 5 5</p> <p>就 爱 我</p>	<p>6 7 7 1</p> <p>然 后 不</p>

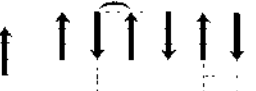
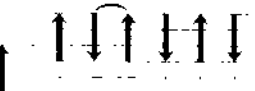
<p><b>G</b></p> 	<p><b>A</b></p> 	<p><b>Bm</b></p> 	<p><b>E</b></p> 
			
<p>1 7 6 5 5 5</p> <p>要 太 罗 唆</p>		<p>3 2 1 6</p> <p>青 春 的 滋</p> <p>长 春 大 的 滋</p> <p>来</p>	<p>6 1 6 3 3 6 6</p> <p>味 尝 的 不 够</p> <p>良 心 的 折 磨</p>







G A

Mr.

3 3 3 3

x x x x

1 — — — 6 — 0 1 2 3

第一次 %

D D D D

7 5 7 7 7 7 8 10 10 7 8 7 7 7 7 5

0 b7 1 3 3 3 4 5 5 3 4 3 3 1 1 b7

(E.G+Drive)

D D D D

7 5 7 7 7 7 8 10 10 7 8 7 7 7 7 5

3 2 2 1 1 6 6 5 3 2 2 1 1 5 1 1 — — — 0 0 3 4 4 5

所以 我 要 永 远 是 现 在 的 我 能 不 能

N.C.

5 — 1 7 7 5 5 — — —

不要 说 Fine





G D Cadd9 G

很久不见 你现在 都还好吗 你曾说过 你不愿一个人 我们都  
 最真的梦 你现在 还记得吗 你如今也 是一个有故事的人 天空

Asus4 A Em7 Cadd9 D

活在这个城市 里面 却为何 没有再见面 却只和 陌生人 擦肩  
 下着一样冷 冷的雨 落在 同样的时间 昨天已 越来越 遥远

Cadd9 D G Bm7 C

有没有 那么一首歌 会让你 轻轻跟着和 牵动 我们共同过去 记忆  
 随着 我们生命起伏 一起

D G Bm7 C D

它不会 沉默 有没有 那么一首歌 会让你 心里记着我 让你 欢喜 也让你忧这么  
 从未沉默过 唱的主题歌 心里记着我 突然想起我

G Asus4/E F G

一个我

(Piano)



F G Am7 Bm7 C D

4 3 | 5 2 — 0 5 4 | 3 5 1 2 3 5 1 2 3 5 1 2 3 2 1 | 5 4 3 3 2 1 | 5 5 4 3 2 1 2 | 3 2 1 1 | 1 7 5 2 1 7 5 6 7 1

Am7 Bm7 D C D G

2 · 1 1 · 3 3 2 1 5 1 2 3 4 | 5 · 1 7 5 · 1 7 5 — :| 6 5 0 5 3 6 5 3 2 | 2 1 1 1 0 1 7 5 ·

欢喜 也让你忧这么 一个我 有没有

C D G N.C.

(Drum Only)

6 5 0 5 3 6 5 3 2 | 2 1 1 1 0 1 7 5 | 3 2 3 2 3 0 1 7 5 | 3 2 3 2 3 3 0 3 5 |

欢喜 也让你忧这么 一个我 我现在 唱的这首歌 若是让 你想起了我 涌上

G

2/4 0 1 7 5 | 3 2 3 2 3 0 1 7 5

来的 若是寂寞 我想 知道为什么 吗 有 没 有 那么一首歌 会让你

Bm7 C D G D G

3 2 3 5 6 6 5 3 3 5 | 6 5 5 5 3 6 5 3 2 | 2 1 1 1 0 1 7 5 | 3 2 3 2 3 0 1 7 5

突然想起我 让你 欢喜 也让你忧这么 一个我 我现在 唱的这首歌 就代表



Bm7 C D G

3 2 3 2 3 3 0 3 5 6 5 0 5 3 6 5 1 3 | 3 2 2 2 1 2 0 1 7 5 3 2 3 2 3 0 1 7 5 |

我对你诉说 就算日子匆匆过去我们曾一起走过我现在唱的这首歌就代表

Bm7 C D G Am7 Bm7 C D

3 2 3 3 5 6 6 5 3 0 3 5 6 5 5 5 3 6 5 0 3 2 | 2 1 1 1 0 0 3 5 6 5 0 5 3 6 5 0 3 2 |

我对你诉说 就算日子匆匆过去我们曾走过 就算日子匆匆过去我们

Cadd9 G/B Am7 D G

2 1 1 1 1 1 - 0 0 0 0 | 1 - - - 1 - - -

曾走过

Fine



# 开不了口

词/徐若瑄 曲/周杰伦 演唱/周杰伦



A



A



0



4/4 ♩ = 70



Soul

Aadd9

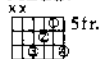

3/4 4/4 4/4 4/4

3 2 5 3 5 2 | 4 5 5 7 5 2 5 7 | 4 5 3 3 5 3 4 | 2 5 2 5 7 5 1

E



D



E

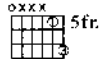

A



E



Dadd9



E



3 2 3 4 | 2 1 2 3 | 5 — — | 5 — —

(Violin)

A



E



#Fm7



Dadd9



Esus4



0 2 2 2 2 2 1 2 2 2 | 0 2 2 2 2 2 3 1 1 | 0 2 2 2 2 3 1 1 1 | 2 2 2 2 3 1 1 —

才离开没多久就开始 担心今天的你过得好不好 整个画面是你 想你 想的睡 不着



A E #Fm7 Dadd9 E E#G

0 2 2 2 2 2 1 2 2 2 0 2 2 2 2 2 3 2 2 3 1 1 0 3 3 5 5 3 3 3 5 5 5 3 2 5 1 1 0

嘴 嘟 嘟 那 可 爱 的 模 样 还 有 在 你 身 上 香 香 的 味 道 我 的 快 乐 是 你 想 你 想 的 都 会 笑

#Fm E#G A #Fm E#G A

3 2 1 5 3 2 1 1 1 — — — 3 2 1 5 3 2 1 1 1 — — — 0 5

没 有 你 在 我 有 多 难 熬 (没有你在我有多难熬多烦恼) 没 有 你 烦 我 有 多 烦 恼 (没有你烦我有多烦恼多难熬) OH

#Fm E#G D Bm7 #Cm7 Dmaj7 Esus4 E

3 2 1 5 3 2 1 6 6 6 5 5 5 6 5 5 3 0 3 5 6 6 6 5 5 5 3 3 3 5 5 5 1 1 1 7 6 5 5 5 0 1 1

穿 过 云 层 我 试 着 努 力 向 你 奔 跑 爱 才 送 到 你 却 已 在 别 人 怀 抱 就 是

A #Cm7#G E#G #Fm #Cm7/E

1 1 1 1 2 2 3 3 3 — 2 3 3 3 5 1 1 1 1 2 2 2 3 3 3 — 0 3 6 7

开 不 了 口 让 她 知 道 我 一 定 会 呵 护 着 你 也 逗 你 笑 你 对 我

Dmaj7 #Cm7 #Fm7 Bm7 Esus4 E

6 6 7 7 6 6 6 7 7 6 6 6 6 5 0 5 5 3 5 5 5 3 3 5 5 5 3 3 3 2 1 2 2 1 1

有 多 重 要 我 后 悔 没 让 你 知 道 安 静 地 听 你 撒 娇 看 你 睡 着 一 直 到 老 就 是

A  $\#Cm7/\#G$  E/ $\#G$   $\#Fm$   $\#Cm7/E$

1 1 1 1 2 2 3 3 3 — 2 3 3 3 5 1 1 1 1 2 2 2 3 3 3 — 0 3 6 7

开不了口让她知道 就是那么 简单几句我办不到 整颗心

Dmaj7  $\#Cm7$   $\#Fm7$  Bm7 Esus4 E

6 6 7 7 6 6 6 7 7 6 6 6 6 5 0 5 5 3 5 5 5 3 3 3 5 5 5 3 3 3 2 1 2 2 3 2 1

悬在半空我只能够 远远看着 这些我 都做得 到但那个人 已经不是 我

A E Dmaj7 E6

1 5 3 1 5 2 5 3 | 5 2 5 5 7 2 5 1 4 5 3 4 6 3 4 1 5 3 5 7 3 4 3 5 5 2

A E D Dadd9 E

3 2 3 4 5 — — — 4 — 5 — 5 — 6 7 1 2 7 :

(Violin)

Esus4 E A E D

3 2 1 2 2 0 1 1 — — — 1 2 1 3 2 2 — 6 — — —

已经不是 我







# 简单爱

词/徐若瑄 曲/周杰伦 演唱/周杰伦



C



C



0



4/4 = 97



Soul

C G

0 0 0 0 | 0 0 0 0 0 2 2 1 7 1 0 2 2 1 7 1

Am F C G

0 2 2 1 7 1 0 2 2 1 7 1 0 2 2 1 7 1 0 2 2 1 7 1

Am F C Gsus4

0 2 2 1 7 1 0 2 2 1 7 1 0 6 6 1 1 6 1 0 6 6 1 1 6 1

说不上为什么 我变得很主动



Am F C Gsus4

0 6 6 1 1 6 1 5 6 | 1 6 1 2 2 1 1 | : 0 6 6 1 1 6 1 | 0 6 6 1 1 6 1 |

若爱上一个人什么 都会值得去 做 我想大声宣布 对你依依不舍

Am F Am7 Dm11 Gsus4 C G/B

0 6 6 1 1 6 1 5 6 | 1 6 1 2 2 1 1 | 0 1 1 1 1 0 1 | 7 6 7 1 1 5 1 |

连隔壁邻居都知道 我现在的感 受 河边 的风 在 吹着头发 飘动

Am7 Dm11 Gsus4 C G/B Am7 Dm11 Gsus4 Am

0 1 1 1 1 0 1 | 7 6 5 5 5 4 4 5 | 0 5 1 1 1 5 1 | 7 6 7 1 1 2 3 |

牵着 你的 手 一阵莫名 感动 我想 带你回我 的外婆家 一起

B Gsus4 C G/B

4 4 4 3 3 2 5 | 4 4 4 3 2 1 1 | 0 5 1 2 3 2 3 4 | 5 5 5 4 3 2 2 |





看着日 落 一直 到我们都睡 着 我想就这样牵着 你的手不放 开

Am Em F C/E

0 5 1 2 3 2 3 4 | 5 5 5 6 5 3 3 | 0 1 6 2 2 3 3 | 0 5 1 5 1 7 1 |





爱能不能够永远 单纯没有悲 哀 (我)想带你骑单车 (我)想和你看棒球

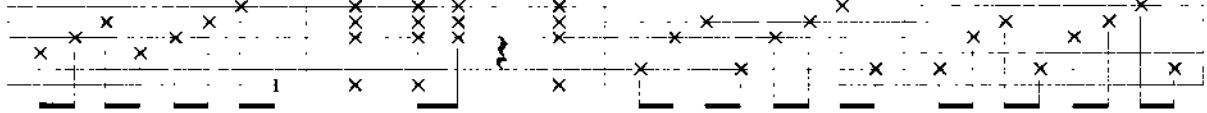

Dm7  

Gsus4  

C  

G/B  

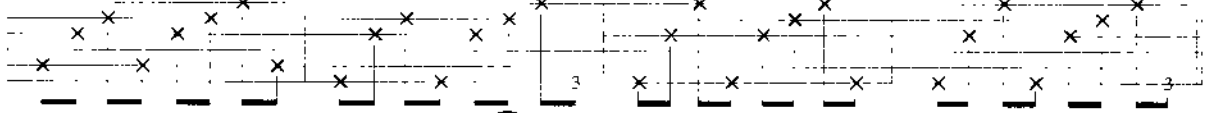





0 1 6 2 2 3 3    4 4 4 3 2 1 1    0 5 1 2 3 2 3 4    5 5 5 4 3 2 2  
 想这样没担忧    唱着歌一直走    我想就这样牵着    你的手不放 开

Am  

Em  

F  

C/E  

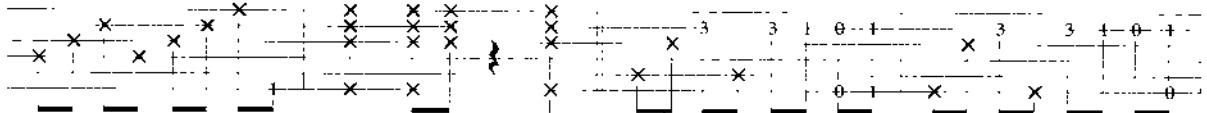





0 5 1 2 3 2 3 4    5 5 5 6 5 3 3    0 1 6 2 2 3 3    0 5 1 5 1 7 1  
 爱可不可以简简    单单没有伤 害    (你)靠着我的肩膀    (你)在我胸口睡着

Dm7  

Gsus4  

C  

G  

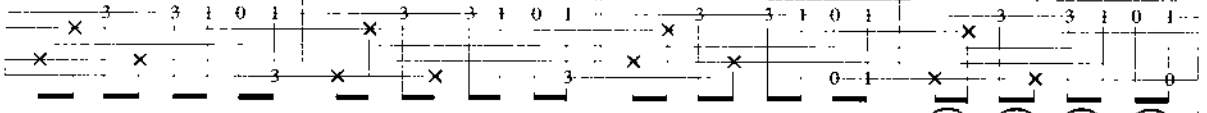



0 1 6 2 2 3 3    4 4 3 2 1 1    1 — — —    1 7 7 6 6 5 6 7  
 像这样的生活    我爱你 你爱我    想    简 简 单 单

Am  

F  

C  

G  

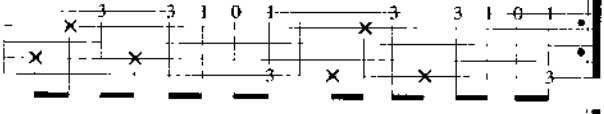

1 — — —    0 0 0 0    1 — — —    1 7 7 6 6 5 6 7  
 爱    想    简 简 单 单

Am  

F  



1 — — —    0 0 0 0 :||  
 爱    %



Chord diagrams: C, Dm7 (3fr), Em7, Dm7 (3fr), C, Dm7 (3fr), Em7, Dm7 (3fr).

Fingerings: 1, 1, 1, 5, 1, 1, 1, 0, 0, 0, 0, 0, 0, 0.

(G.T APG)

Chord diagrams: C, C.

Fingerings: 0, 0, 0, 0, 0, 0, 0, 0.

Fine



# 爱的就是你

“哇哈哈纯净水”广告曲 / “蜜桃女孩”连续剧主题曲

词 / 王力宏、楼南蔚、黄慧宁 曲 / 王力宏 演唱 / 王力宏



Key



Play



Capo



Tempo



Rhythm

Soul

Chords: F, C/E,  $\flat B$ ,  $\flat A$  4fr., F

0 0 5 6 5 0 7 7 — 5 6 7 6 6 — 5 6 6 5 5 — — —

Chords: C/E,  $\flat B$ ,  $\flat Bm/\flat A$  4fr.

0 0 5 6 5 0 7 7 — 5 6 7 6 6 — 0 2 3  $\flat 3$  — — —

Chords: F, C/E,  $\flat B$

3 — — — | 0 3 5 5 4 3 2 1 1 1 — 0 6 1 1 6 1

失去才会懂得珍惜 但我珍惜你



Fmaj7 3fr. F C/E bB

1 6 5 5 — — 0 3 5 5 4 3 2 1 1 1 — 0 0 1 1 2 2 2

伤越痛 就是 爱 越深 我不相信

C Gm7/D C Am7

2 — 0 0 0 4 4 4 3 4 3 2 1 1 2 2 0 5 5 5 4 5

你和我 同时 停止呼 吸 每一次 我们

D Gm Gm/bG Gm7/F

4 3 3 3 — 0 4 4 4 3 2 3 4 4 4 4 — 4 4 4 4 4 5 3 2

靠 近 你让 我忘 了困 惑 忘了 所有烦心

A F C/E bB

2 — 0 5 2 5 2 1 2 1 2 3 0 5 5 3 5 3 5 6 0 5 6 1 1 1 1 7 6 5

我把你 紧紧拥入怀里 捧 你在我手心 谁 叫我真的爱的就是

Am bB Am Dm Gm

3 — — 0 5 6 1 1 1 7 6 6 5 5 5 3 5 2 1 1 3 2 2 1 1 6 1 2

你 在 爱的纯净世界 你 就是我惟一 永远永远不要怀疑

C F C/E bB

2 — 0 5 2 5 2 1 2 1 2 3 0 5 5 3 5 3 5 6 0 5 6 1 1 1 1 7 6 5

我把你 当作我的空气 如 此形影不离 我 大声说我爱的就是

Am bB Am Dm Gm Gm/C

3 — — 0 5 6 1 1 1 7 6 6 5 5 5 3 5 2 1 0 5 3 2 2 1 1 6 6 1

你 在 爱的幸福国度 你 就是我惟一 我 惟一爱的就是你

F Gm Gm/C F (G.T1 Similar) C/E

1 — 0 0 6 3 2 2 1 1 6 6 1 1 — 2 3 5 5 6 5 5 — 0 3 5 5 6

我 真的爱的就是你 (G.T2 Solo)

Dm Gm/C F bB C

6 — — — 5 — — — :| 1 — 0 5 6 1 1 — — 5 6 5

就是你 Yeah

bB F bB Am

5 6 6 — — 0 0 0 3 5 1 1 — 0 5 6 1 1 — — 5 6 5

就是你 就是你 Yeah





惟一爱的就是你

我把你

我 惟一爱的就是你 我 真的爱的就是

你 **Rit.....** **Fine**

# It's Just Love

“蜜丝佛伦化妆品”电视广告

词/米希亚 曲/米希亚、乌野晴 演唱/米希亚

**Key** E **Play** C **Capo** 3 **Tempo** 4/4 = 80 **Rhythm** Slow Soul

**Fmaj7** **G** **Em** **Am** **Fmaj7** **G** **Em** **Gm7** **C7**

3 2 2 — 7 2 1 1 — 3 2 2 — 7 4 4 3 3

Hu..... Hu.....

**Fmaj7** **G** **Em** **Am** **Fmaj7** **Fmaj7/G** **G**

3 2 2 — 7 2 1 1 — 3 6 6 3 3 3 2 2 —

Mm.....

**Fmaj7** **G** **Em** **Am** **Fmaj7** **Gsus4** **G** **Cmaj9** **Gm7** **C7**

0 1 1 1 1 7 6 5 5 3 2 1 1 — 0 6 6 6 6 6 7 1 2 6 6 5 —

NaNiKi Na I Hi To Ko To Ni KiZuTu Ki Ga Tu I Ta

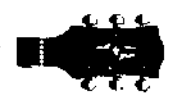

Fmaj7 G Em Am Fmaj7 Fmaj7 G #Fm7-5

0 1 1 1 1 1 7 6 5 5 5 3 2 1 1 2 3 | 4 3 4 3 1 6 3 3 | 3 2 2 0 5 1 2 |

E Ga O De Ka Ku Se Na I Hodo Mou Ha Zi Ha Te I Ta Ko I It's just

Fmaj7 G Em Am Fmaj7 G Em Am

3 2 2 7 6 5 2 7 1 0 5 1 2 | 3 4 2 2 3 5 | 6 5 3 1 1 — |

love Zi Bunn Ni Sa E It's just love U so O Tu I Te

Fmaj7 Em7 Fmaj7 Gsus4 G

0 6 6 6 6 6 6 7 1 7 0 7 7 7 7 7 1 2 1 0 1 1 1 1 1 1 2 3 1 | 6 5 3 5 5 —

To Ma Do I To Me Do Na Ku Na Mi Ta Ni Na Ga Sa Lc Te I Ma Wa Ma Da Ko Da E Sa Ga si Te Lu

G Cmaj9 Am Fmaj7 G Cmaj9 Am

0 0 0 1 7 1 1 1 7 1 1 1 7 1 | 1 2 3 4 4 4 2 1 7 1 | 1 1 7 1 1 1 7 1 |

A I Tai A I Tai I Ma Su Gu Ni De Mo A I Tai A I Tai Su Na O

Fmaj7 G Em Am7 Dm7

1 2 3 4 4 2 3 4 5 5 5 5 5 5 4 3 2 2 1 1 5 2 3 4 5 4 4 5 4 5 2 1 |

Ni Na Le Zu He Ya No A Ka Li Mo Tu Ke Na I Ma Ma He To Li Ki Li De Zi Kann To Me



G **bB6** A F Em

3 4 2 3 4 5 3 5 3 5 5 3 5 5 6 3 3 2 3 3 5 2 3 4 3 2 2 1 2 2 5 5 5 5

Ta Ma Ma A No Hi No O Mo I De Da Ki Si Me Te Zyu Wa Ki Ni Te O Da Ke Te Yu

Fmaj7 Em F F/G G

4 3 2 2 1 2 2 6 5 5 5 4 3 2 2 1 4 3 2 2 1 2 2 — 2 5 6 1 6 6 5 5 5 5 3 2 2

Bi Ga O Bo E Te Lu Zi Sa Ku Ma Na Bu Nan Ba Si Zu Ka Ni Na Zo Ta

Cmaj9 Am7 Fmaj7 G Cmaj9 Am7 Fmaj7 G

2 1 1 0 3 5 1 3 2 2 — 2 1 1 — 3 2 2 —

Mm..... La La.....

G F Em7

0 0 0 0 :|| 6 5 5 5 5 3 2 2 3 3 — 3 2 1 1 — 0 5 3 2

I I need you U Na Tu I Te U Na Tu

F Em7 bB6 Dm7



2 3 3 — 3 6 5 5 — — — 6 — 6 5 5 3 6 6 5 — —

I Te H u.....

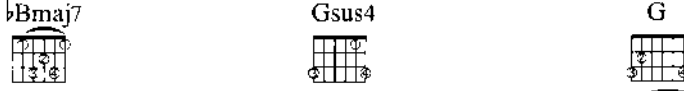
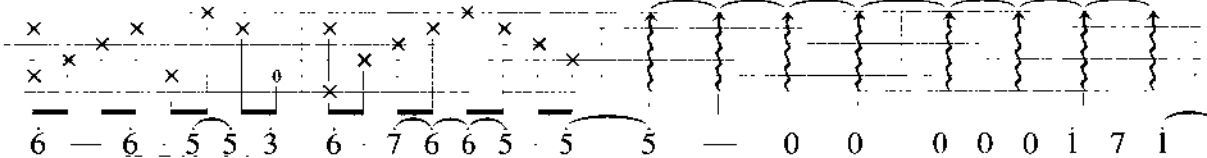

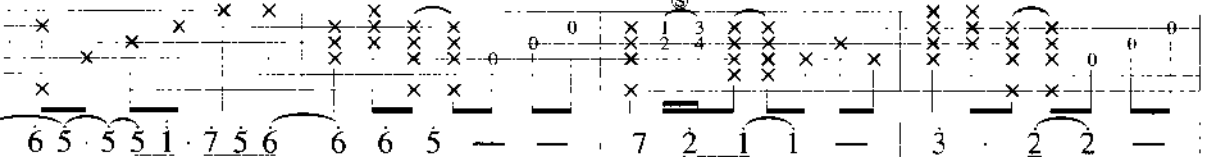

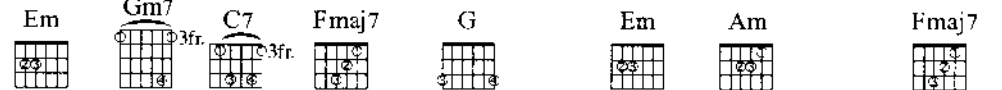

  
 Hu..... I want see you tonight A I Tai %

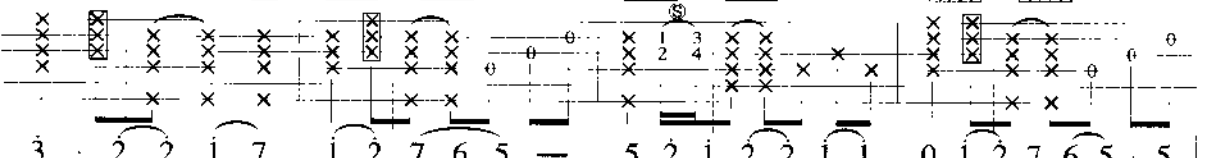







  

  
 Da Ki Si Ma Ta



  

  
 Wu..... Mm.....





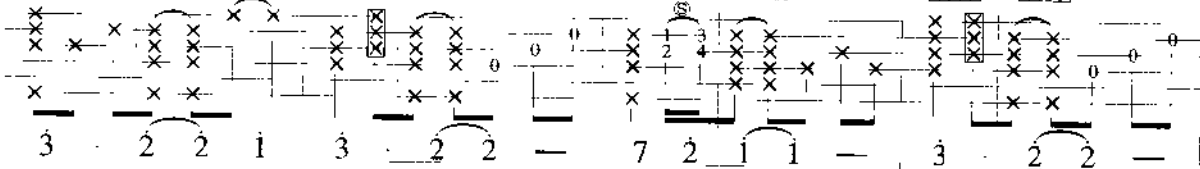



  

  
 O I want see you tonight I want to



  

  
 hold you tied I want I want





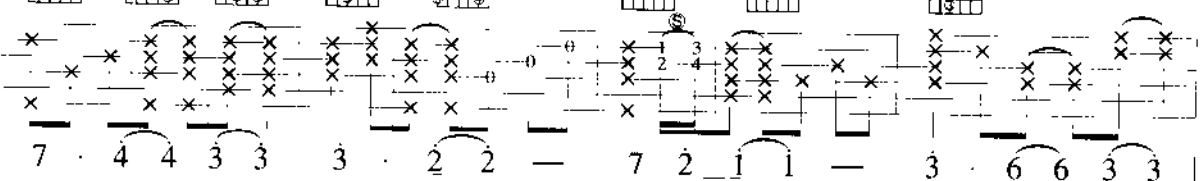









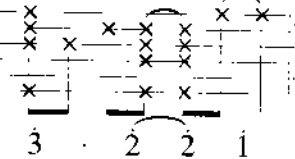





Fade Out





C Em Am Em

0 1 7 1 1 3 4 5 5 — — — 0 6 6 6 5 4 6 5 2 3 3 — —

HaHaGa KuLeTa Ta KUSann No Ya Sa Si Sa

F G Em Am F G

4 5 5 5 3 5 6 6 6 — 0 4 5 6 1 1 1 2 7 6 6 5 5 —

Ai Ga O I Da I Te A YuMeTo KuLi Ka E Si Ta

C Em F  $\nu$ A C/G

0 1 7 1 7 1 1 3 5 5 — 6 5 4 3 4 4 4 6 6 6 5 4 6 5 — — —

A NoToKiWa MaDa O Sa Na Ku Te I MiNaDo Si La Na I

Am Em Dm G C

0 6 7 1 1 1 1 2 3 3 3 4 3 2 1 3 2 0 6 7 7 7 1 2 2 1 1 1 — —

Sonn Na WaTaSiNo Te O Ni Gi Li ISyoNi AYunnDe Ki Ta

Dm G C F G Em Am

2 0 6 7 7 7 1 2 | 2 1 1 1 — 0 6 6 4 3 4 2 7 7 0 6 7 7 5 4 5 4 3 3 0 3 3 2

I SyoNi A Yunn De KiTa SoNo YaSaSiSa O ToKiNi WaI YaGaLi HaNaLe





F G C Em7/B

1 0 6 6 7 1 6 1 3 3 2 2 2 — 3 2 1 1 1 2 3 4 3 4 2 1 2 2 7 7

Ta HaHa E SuNa ONi NaLeSu Ho La A Si MoTo O Mi TeGoLann KoLe

Am Am/G F G Em Am

1 0 6 6 7 1 1 2 3 7 7 7 — 1 7 6 6 6 5 4 3 4 5 1 1 4 3

Ga ANaTaNoAYu MuMiChi Ho La Ma E O Mi Te Go Lann A Le

Dm G C C Em7/B Am Am7/G

4 0 4 4 3 2 1 7 2 1 1 — 0 5 4 3 3 1 7 7 1 2 2 5 6 1 1 7 1 2

Ga ANaTaNoMiLa I

F C/E Dm7 G C Em7/B Am Am7/G

1 2 2 2 1 0 3 3 1 0 7 7 0 2 3 0 2 0 0 0 0 1 3 5 3 3 3 3 5 3 3 3 5 5 8 8 8 3 3 5 3

1 6 6 6 1 5 5 5 1 5 0 2 3 4 5 6 5 5 7 7 2 3 5 5 6 5 5 6 6 1 1 0 2 3 2

F C/E Dm7 G



1 2 1 1 5 7 5 7 5 5 3 5 2 3 5 2 5 4 5 3 3 4 5

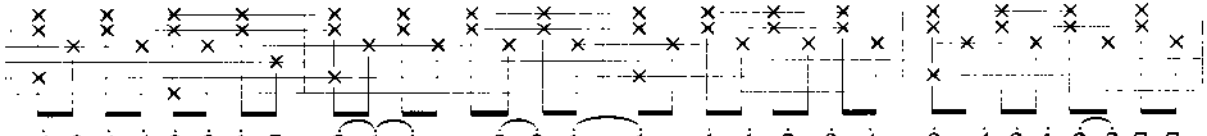

1 6 1 1 6 3 5 3 2 2 1 2 3 4 5 6 1 7 5 2 2 7 5

※





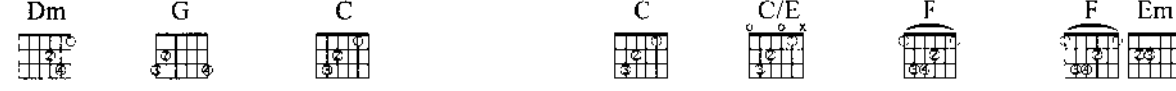

  
 4 0 4 4 3 2 1 7 | 2 1 1 — 3 2 1 | 1 1 1 2 3 4 | 3 4 2 1 2 2 7 7
   
 Ga A NaTa NoMiLa I Ho La A Si Mo To O Mi Te GoLann KoLe

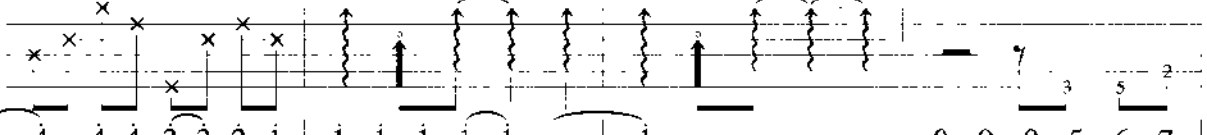

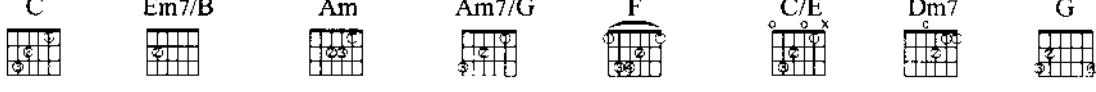
  
 1 0 6 6 7 1 1 2 | 3 7 7 7 — 1 7 6 | 6 6 5 4 3 4 | 5 1 1 4 3
   
 Ga A NaTa No A Yu MuMiChi Ho La Ma E O Mi Te Go Lann A Le

  

  
 4 0 4 4 3 2 1 7 | 2 1 1 — — | 5 7 1 1 5 5 5 | 4 3 4 4 — 0 1
   
 Ga A NaTa NoMiLa I Mi La He Mu Ka Te Yu

  

  
 4 4 4 3 3 2 1 | 1 1 1 1 1 — | 1 — — — | 0 0 0 5 6 7
   
 KuLi To A Lu I Te Yu

  

  
 1 2 3 5 5 6 7 7 1 1 2 1 | 1 — 5 5 7 7 5 6 | 6 5 6 5 5 7 7 1 2 | 1 6 5 5 6 1 7 6 5 5 7 6 5





# 52 二重唱

## Guitar

一般人都认为，要成为一组二重唱，除了要找到二个音色相当、默契要好的人之外，最重要的是二人之中必须要有一个有超于常人的音感（能唱和声的人），这样子才可能被称为是二重唱团体。否则可能会被称为“齐唱”了。所以说，如何唱好和音成了我们要讨论的重点。在这一章里我并不是要教大家唱和声的技巧，而是要来探讨如何来编写一个二重唱的和声谱。

或许你会认为，会唱和声是与生俱来的能力，没错！笔者也曾经见过许多人唱和声的方式，都是凭着一种感觉（Feeling）来唱的，问其是凭着何种感觉？唱什么音？却说不出所以然来，像这种感觉，与其说是天生的，不如说这些人都是对于和弦有着较敏锐的感受能力，但如果要大家天生就都有这种能力可能比较难，惟一的途径就是经过写谱的训练来达成这种和声能力，这种方式可能就比较容易了。

首先，在大家学习本章之前，笔者不得不要求大家必须将和弦组成的乐理概念先建立起来（亦可参照本书第24章—和弦组成），这将会是本章的重点。所以在这一章里，笔者要把大家都当做是一个对于和弦的组成、转位都已了解的人来解说。

笔者提供几种和声编写的要点给大家来做研究：

### 一、旋律根音皆放置于低音部

这种方式为最多人使用，也是最易学的和声方式，这里所指旋律根音事实上就是旋律音。依照和弦观念的说法，在一个音阶上建立一个音程，如果这个音程为一个协和音程（一度、四度、五度、大三度、小三度、大六度、小六度），那么我们就可称之为和声，如果建筑二个协和音程，便可称为和弦。这样子一来，我们可以在每个旋律根音上找到三种不同之顺阶和弦。



旋律根音	使用音	和弦	备注
1 (Do)	1.3.5	C	
	1.3.6	Am	和弦转位
	1.4.6	F	和弦转位
2 (Re)	2.4.6	Dm	
	2.5.7	G	和弦转位
	2.4.7	B <sup>-</sup>	尽量不用
3 (Mi)	3.5.7	Em	
	3.5.1	C	和弦转位
	3.6.1	Am	和弦转位
4 (Fa)	4.6.1	F	
	4.6.2	Dm	和弦转位
	4.7.2	B <sup>-</sup>	尽量不用
5 (Sol)	5.7.2	G	
	5.1.3	C	和弦转位
	5.7.3	Em	和弦转位
6 (La)	6.1.3	Am	
	6.2.4	Dm	和弦转位
	6.1.4	F	和弦转位
7 (Si)	7.2.4	B <sup>-</sup>	尽量不用
	7.2.5	G	和弦转位
	7.3.5	Em	和弦转位

左边的图表中，我们的讨论仅就三和弦来做讨论，暂时不讨论七和弦，而且将旋律音摆在最低的位置来做配置，由此看来，不同的和声音可以变成不同的和弦效果，反过来说，和声的配置必须在适当的和弦下来加入。

## 二、最好不要使用平行音程的做法

这是最不愉悦的和声方式。所谓平行音程的做法就是说，不管和弦为何，在每个旋律音上都加入一个平行音程（三度或五度），这种和声最容易有问题，尤其是在大调与小调的分辨上容易混淆，譬如说，Am小调歌曲旋律音是3（Mi），和声音可能是6（La），但如果不考虑和弦，可能会把它唱成5（Sol），让人有大调的感觉，这时必有不协和的情况发生，所以说尽量不要使用平行音程的和声方式。

## 三、避免让和声音程起伏太大

国内外有很多知名的二重唱团体，和声的方式并非使用单一种的和声方式，也就是说，可以使用高低声部互换的和声法，或使用和声交唱的和声方式，因为很可能你的高音极限没办法唱到和声的高音域，这时你可以将此句和声的唱法改为比旋律音低的声部的和声唱法，或者二人互相轮流唱和声，这样子还可利用音色的互换达到不同的效果，但终就无论你用何种和声方式，最重要的是尽量不要让和声音程起伏太大，一方面是不好唱，一方面是难听。



#### 四、和声的编写必须配置在适当的和弦下

第二点中我们说明了，尽量不要使用平行音程的做法，这时候所使用的和声就得完全依赖该小节的和弦来决定了。在观念上，其实和弦内音也可以把它当做是和声来使用。譬如说，如果有一小节的和弦是 Cmaj7，如果吉他弹的是 C 和弦，那么我们可以让和声唱 7 (Si)，这样子一来，照样可以有 Cmaj7 的和弦感觉。换个角度来看，如果和声音不在和弦的内音中，那可得要小心了，很可能容易唱走音，或者会让和弦性质改变，而让人有不和协的感觉。

下面的练习歌曲，我们以张雨生唱过的一首「大海」来做练习，请大家注意看看副歌上所使用的和声与和弦的关系：





B7 Am Em A

3 3 3 3#5 3 - | 0 2 2 1 3 2 2 1 2 | 1 6 6 6 6 1 6 6 6 1 | 2 2 2 2 2 1 3 2 2 1 2

写成幻影 我站在屋顶 泪和 霓虹迷蒙了眼睛 誓言 欺骗了吹痛相信 我的

D C G C

5 5 5 5 6 3 5 1 2 3 | 6 6 5 6 6 5 6 6 5 6 5 | 5 3 3 - 1 2 3 | 6 6 5 6 6 5 6 6 5 6 1 6

i i 7 i i 7 i i 7 i 7 | 7 5 5 - | i i 7 i i 7 i i 7 i 3 i |

心碎能说给谁听吾爱的 亲爱的可爱的挚爱的永远 无悔 不爱的 错爱的曾爱的伤爱的永远

G Am B7 D

5 3 3 - 3 2 1 | 2 2 2 1 2 6 3 2 1 | 3 3 3 3#5 3 - | 0 1 2 3

7 5 5 | 5 4 3 | #5 5 5 5 7 5 -

无情 我为你 蹉跎 一辈子 你给我 潇洒 几个 字 吾爱的

C G C G

6 6 5 6 6 5 6 6 5 6 5 | 5 3 3 - 1 2 3 | 6 6 5 6 6 5 6 6 5 6 1 6 | 5 3 3 - 3 2 1

i i 7 i i 7 i i 7 i 7 | 7 5 5 - | i i 7 i i 7 i i 7 i 3 i | 7 5 5

亲爱的可爱的挚爱的永远 无悔 不爱的 错爱的曾爱的伤爱的永远 无情 你简单

Am B7 C D

2 2 2 1 2 6 3 2 1 | 3 3 3 3 5 3 6 5 3 | 6 - - - 6 | 5 - - -

#5 5 5 5 7 5 1 7 5 | 1 - - - 1 | 7 - - -

寄出 几个 字 却要我 收下 无静的无声的 哭..... 啊





Em Am C B7

0 0 0 0 0 0 0 0 0 0 0 0 0 0 0 0

(E.G Blues Scale 请自由发挥)

Em C Am B7

0 0 0 0 0 0 0 0 0 0 0 0 0 0 0 0

Fine



### 小七和弦琶音练习 Dm7

1 4 3 1 3 2 1 4 1 2 3 1 3 4 1 1 4 3 1 3 2 1 4 1 2 3 1 3 4 1

5 8 5 6 7 5 7 6 5 5 8 5 6 7 5 7 6 5 5 8 5 6 7 5 7 6 5

和弦根音 和弦根音

注：1 2 3 4 表手指代号。可依次选择任意琴格来作练习。

## 大海

词/陈大力 曲/陈大力、陈秀男 演唱/张雨生

● Key  $\text{C}$  ● Play  $\text{C}$  ● Capo 1 ● Tempo 4/4 ● Fingers | 1 1 2 1 3 1 2 |

C Dm F G C Dm Fmaj7 G

3 · 5 1 3 4 3 2 1 6 · 1 2 - 5 · 5 1 3 4 3 2 1 3 · 1 7 · 6 5

C

1 - - 5 6 1 1 1 1 1 6 5 1 1 1 1 2 1 6 1 2 2 2 2 2 1 6

从那 遥远 海边 慢慢 消失 的 你 本来 模糊 的 脸 竟然

G7 Am Dm Am F G

2 2 2 2 3 2 3 5 | 6 6 6 5 6 5 3 2 2 3 2 1 6 5 6 1 1 1 1 1 6

渐渐 清晰 想要 说些 什么 又不 知从 何说起 只有 把它 放在 心

C C Am Dm

1 - - 5 6 | 1 1 1 1 1 6 5 | 1 1 1 1 2 1 6 1 2 2 2 2 2 1 6



























底 茫然 走在 海边 看那 潮来 潮去 徒劳 无功 想把 每朵

G7 Am Em Am F G

2 2 2 2 3 2 3 5 | 6 6 6 5 6 1 6 5 3 2 1 6 5 6 1 1 1 1 1 2

浪花 记清 想要 说声 爱你 却被 吹散 在风 里 猛然 回头 你在 哪



C 	Am % 	Em 	F 	G 	
1 - - 3 5   <u>1 1</u> <u>1 1</u> 1   3 1   7 7 <u>7 7</u> 1 7   6 5   4 4 <u>4 4</u> 4 6	如果 <u>6 6</u> <u>6 6</u> 6   大海 能 够 唤回 曾 经 的 爱 就 让 我 用 一 生 等				
C 	Am 	Em 	Fmaj7 		
5 - - 5 4   3 3 <u>3 3</u> 3   3 1   7 7 <u>7 7</u> 1 7   5 7   1̇ · 3̇ 3̇ <u>7 1</u>	待 如果 深情 往 事 你 已 不 再 留 恋 就 让 它 随 风 飘				
3 - - 3 2   1 1 <u>1 1</u> 1   1 6   5 5 <u>5 5</u> 6 5   3 5   6 · 1̇ 1̇ <u>5 6</u>					
G7 	Am 	Em 	F 	G 	
7 - - 5 7   1 1 <u>1 1</u> 1   3 1   7 7 <u>7 7</u> 1 7   6 5   4 4 <u>4 4</u> 4 7	远 如果 大海 能 够 带 走 我 的 哀 愁 就 像 带 走 每 条 河				
5 - - 5 4   3 3 <u>3 3</u> 3   4 5   7 7 <u>7 7</u> 1 7   5 7   1̇ - - -					
3 - - 3 2   1 1 <u>1 1</u> 1   2 3   5 5 <u>5 5</u> 6 5   3 5   6 - - -	流 所有 受 过 的 伤 所 有 流 过 的 泪 我 的 爱				
G7 	C 		C 		
0 0 7 5 4 <u>4 3</u>   3 - - -   0 0 0 0   1 - - - <u>5 6</u>	请 全 部 带 走			茫 然	
0 0 5 3 2 <u>2 1</u>   1 - - -					
C 					
1 - - 3 5	走 如果 %				
G7 		C 	Em 	F 	G 
0 0 5 3   2 3 - · <u>2 1</u>   1 - - -   3 · 1 2 -	请 全 部 带 走				
C 	Em 	F 	C 		
5 · <u>5 1 3 4 3</u> 2 1   6 - 4 5 4   3 - - -					

Fine



# 屋顶

词/周杰伦 曲/周杰伦 演唱/吴宗宪、温岚



C → E<sup>+</sup>



A → C



3



4/4, = 88



Slow Soul

A/C



#Fm

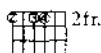

Dmaj7



E6



(E.P.)

0 5 5 1 1 7 1 | 0 5 5 1 1 7 1 2 | 3 1 1 - 3 4 2 2 3 3

#Fm



#Fm/E



Dmaj7



1 - - 0 1 7 5 5 3 3 | 6 6 1 1 - - -

A



#Fm7



D



E



(男) 半夜睡不着觉 把心情哼成歌 只好到屋顶找另一个梦境

0 5 5 1 1 7 1 | 0 5 5 1 1 7 1 | 0 5 5 1 1 7 6 7 | 1 7 6 6 7 7 1



A Adim C Am

1 0 0 0 0 0 5 5 1 1 7 1 | 0 5 5 1 1 7 1

(转C调) (女)睡梦中被敲醒 我还是不确定

Dm7 G C Am

0 5 5 1 1 7 6 7 | 1 2 2 3 6 5 5 | 0 5 5 1 1 7 1 | 0 5 5 1 1 7 1

怎会有动人旋律 在对面屋顶 我悄悄关上门 带着希望上去

Dm7 G E Esus4#G Am

0 5 5 1 1 7 6 7 | 1 1 1 2 3 2 2 | 0 0 0 0 | 0 0 0 0

原来是我梦里常 出现的那个人

(男)那个人不就是我梦里那 模糊的人 我们有

Dm7 G C G/B Am Dm7

1 7 1 2 2 3 3 3 | 0 0 0 3 2 1 | 1 - 0 1 7 1 | 1 2 2 3 3 1 1 2

同样的默契 用天线 排成爱 你的形状

(女)用天线 排成爱 你的形状



G G C G/B Esus4/G

2 — 2 3 3 2 0 0 0 0 0 5 1 2 2 3 2 1 2 — 2 3 2 1

(男)在屋顶和我爱的人 哦

4 — 4 5 5 4 0 5 3 4 4 5 3 4 5 — — 0 5 5 4 4 3 2 3

(女)在屋顶唱着你的歌 让星星点缀成最

Am Am7/G F Em A

6 6 6 6 7 7 1 1 0 5 5 1 7 6 0 7 1 7 7 6 5 5 0 3 2 2 b1 b1 b1 2

浪漫的夜晚 拥抱这时刻 这一分一秒 全都停止

2 1 1 1 2 2 3 3 0 5 5 1 7 6 0 7 1 2 2 1 7 7 0 5 4 4 3 3 3 4

浪漫的夜晚 拥抱这时刻 这一分一秒 全都停止

Dm7 G C G/B Esus4/G

2 6 4 3 3 2 2 0 0 0 0 0 0 5 1 2 2 3 2 1 2 — 2 3 2 1

(男)爱开始纠结 在屋顶和我爱的人 哦

Am Am7/G F Em A

6 6 6 6 7 7 1 1 0 5 5 1 7 6 0 7 1 7 7 6 5 5 0 3 2 2 b2 b2 b2 2

最孤独的夜晚 拥抱这时刻 这一分一秒 全都停止

2 1 1 1 2 2 3 3 0 5 5 1 7 6 0 7 1 2 2 1 7 7 0 5 4 4 3 3 3 4

最孤独的夜晚 拥抱这时刻 这一分一秒 全都停止



**Dm7** **G** **C** **Fmaj7**

1.

2. 6 4 3 3 2 2 | 0 0 5 1 2 1 1 | 3. 1 1 1 2 3 | 3. 2 2. 1

爱开始 结 梦有你而美 (E.P.)

4. — — — 0 0 5 5 4 4 3 ||

梦有你而美

**E** **Am** **Am7/G** **Fmaj7** **Dmaj7**

3fr. 3fr. 2fr.

7 — 7 2 7 1 | 1 3 7 1 | 6 — — 4 5 6 7 1 2 | 3. 6 6. 3 |

(转A调)

**#Cm7** **Bm7** **#Cm7** **Dm7** **Em** **F**

4fr. 2fr. 4fr. 2fr.

12 9 9 9 11 | 10 11 10 12(14) 10 12(14) 10 12 12 12 12 9 | 13 15 12 14 14 14 14 12

2 3 3 5 5. 6 1 | 1 6 1 3 3 4 3 2 1 | 2 3 3 5 5 3 2 5 | 6 4 1 2 3 1 2 2 5 3 2 1 |

(转C调)

**E** **C**

2.

12 7 12 14 15 12 13 13 13 | 15 17 17 17 17 17 17 17 | 12 12 12 12 12 12 12 12 | 13 15 12 14 14 14 14 12

1. 2 3 4 5 1 1 6 1 | 3 — — — 3 — — — :|| 1. 7 7 1 5 |

(E.P.)





# 广岛之恋

词/张洪量 曲/张洪量 演唱/张洪量、莫文蔚



#G — B

Key



G — bB

Play



1

Capo



4/4 J = 64

Tempo



Slow Soul

Rhythm

G9 G6sus4 G9

0 0 0 5 5 - 4 3 1 - - 5 5 - 6 3

D Em Am7 D

5 - 6 7 1 - 2 3 | 5 4 3 1 | 5 - 4 3 4

D G9 G6sus4 G9

2 - - - 5 5 5 5 4 3 1 - - - 5 5 5 5 6 3 6 |

(男)你早就该拒绝我 不该放任我的追



D G9 G6sus4 G9

6 5 5 - - | 5 5 5 5 4 3 1 - - - 5 5 5 5 6 3 6

求 给我渴望的故 事 留下丢不掉的名

D C Bm Em Am7

6 5 5 - - || 6 1 1 2 6 - 5 3 3 2 1 - 2 6 2 6 2 6 2 6

字 (女)时间难倒回 空间易破碎 二十四小时的爱情

G9 Am7 G9 G9

5 6 1 6 5 6 3 1 | 1 2 2 5 1 3 - - - 5 5 5 5 4 3

是我一生难忘的美丽回 忆 (男)越过道德的边

G6-11 G9 D G9

1 - - - | 5 5 5 5 6 3 6 6 5 5 - - 5 5 5 5 4 3

境 我们走过爱的禁区 享受幸福的错

G6-11 G9 D C

1 - - - | 5 5 5 5 6 3 6 6 5 5 - - | 6 1 1 2 6 -

觉 误解了快乐的意义 (女)是谁太勇敢



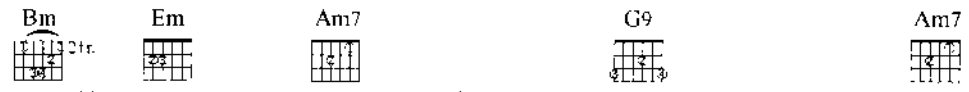

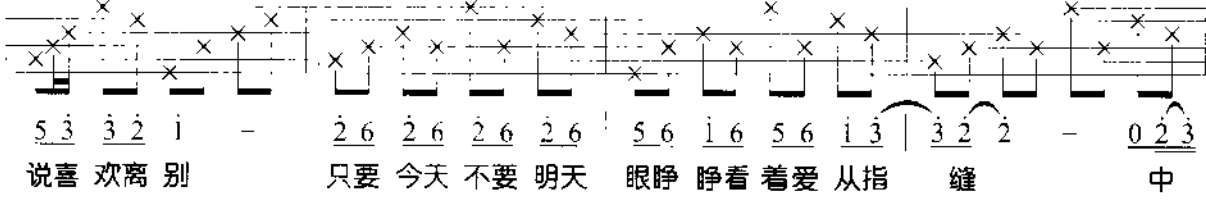



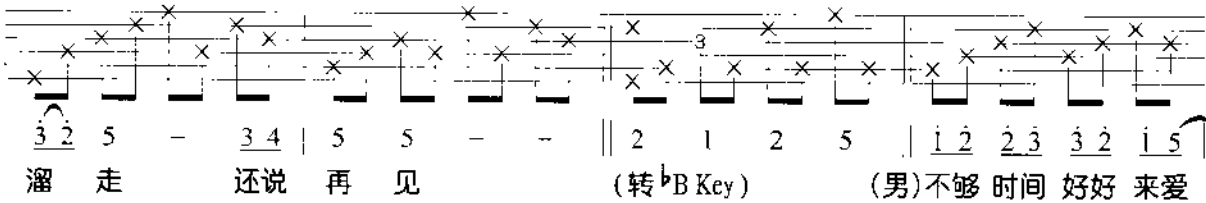



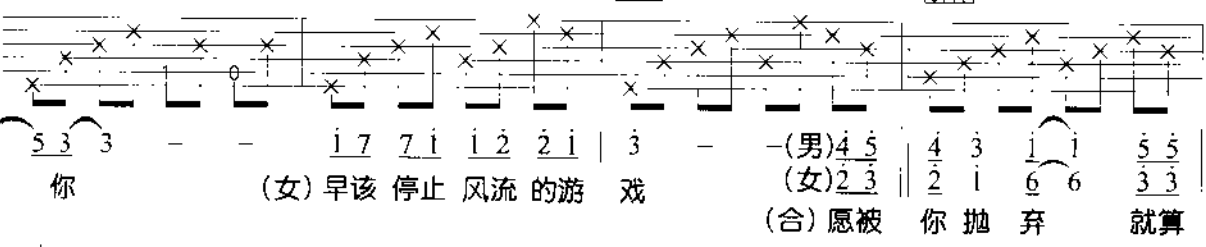





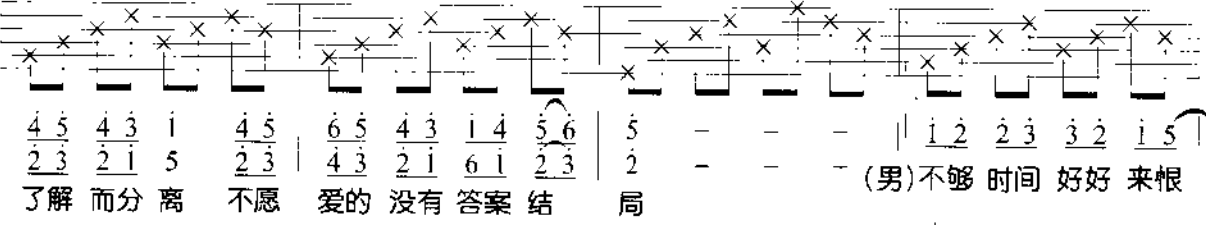





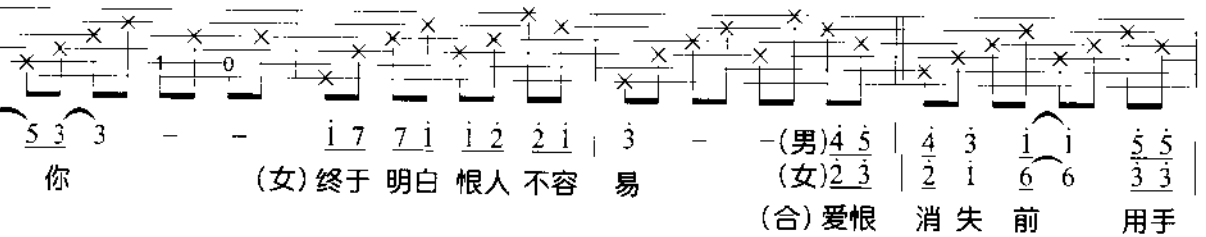

















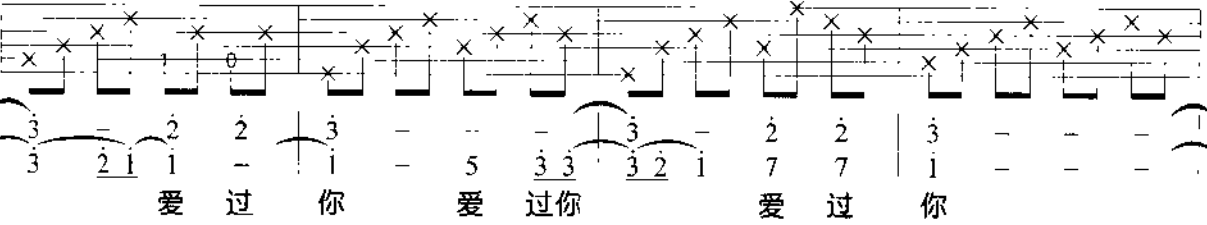







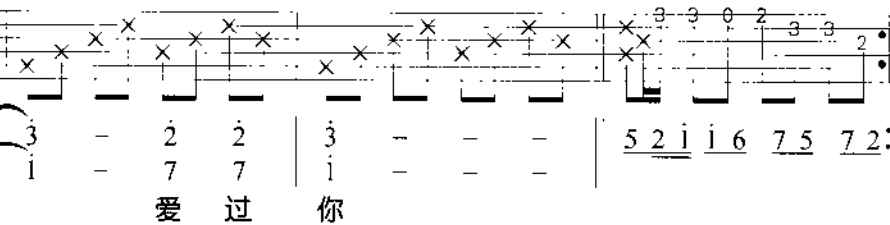











Fine



# 53 Guitar Finger Style

## 演奏曲

在民谣吉他的弹奏上，有很多的人都是使用Pick来搭配弹奏，比较高段的琴友甚至已经可以使用Pick将指法完整弹出。虽然Pick的摆动是民谣吉他技巧中很重要的课程之一，却也让人容易误解为民谣吉他的弹奏只是单纯的刷刷Chord而已。有鉴于弥补手指练的不足，特别增辟此单元，让各位琴友在弹唱之余，也能学习另外一种演奏风格的演出。

所谓Finger Style的演奏，泛指所有使用手指头所弹奏出来的音乐形态，大家比较常听到的多半是在“古典”或是“佛朗明歌”的音乐当中使用古典吉他来表现，但是在国外使用民谣吉他来弹奏这类演奏音乐的乐手，却早已族繁不及备载，诸如：Alex De Grassi、Don Ross、Peter Finger、Steven King……等等都是，国内部份则自董运昌——“听见蓝山的味道”一举得到金曲奖最佳演奏奖之后，开始渐渐有人开始注意这类的Finger Style演奏风格。

一般的FingerStyle演奏方式可选择使用手指或是使用指套的方式，如下图：

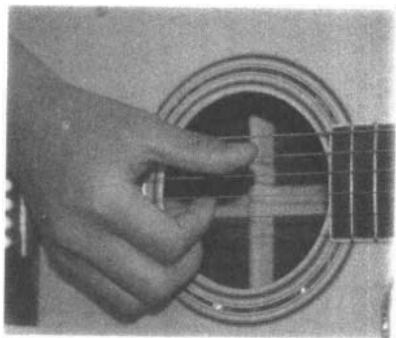

【一】使用手指弹奏

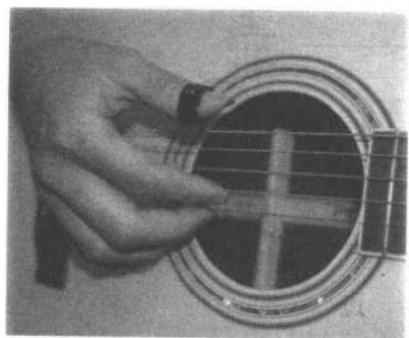

【二】使用指套代替手指弹奏



# Romance

韩剧“蓝色生死恋”主题音乐

♯ Key **Em-E**

🎸 Play **Em-E**

🕒 Tempo **3/4** ♩ = 104

🎵 Rhythm **Waltz**

**Em**

3 3 3 | 3 2 1 | 1 7 6 | 6 1 3

**Am**

6 6 6 | 6 5 4 | 4 3 2 | 2 3 4

**B7**

3 4 3 | #5 4 3 | 3 2 1 | 1 7 6

**B7**

7 7 7 | 7 1 7 | 6 6 6 | 6 1.2.

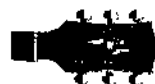

Em 3.4. E #Fm7

6 — — :| 3 3 3 3 2 1 | 1 7 7 |

(转E调)

B7 E

7 7 7 | 6 6 6 | 6 7 6 | 6 5 5 |

E A

5 6 7 | 1 1 1 | 1 7 7 | 6 6 6 |

A E B7 E

6 5 4 | 3 3 3 | 3 4 2 | 1 1 1 ||

E

1 — —

D.C. N/R







C G/B Am F C F D7/#F G

3 0 3 3 3 0 3 0 1 2 2 2 2 3 3 2 0 1 0 3 3 2 0 2 0 0

5 · 3 2 2 5 3 | 3 · 1 6 6 — | 0 5 1 3 4 3 2 | 2 — — —

F C/E Am7 Am7/G F Dm7 C/E F6 D7/#F G

2 0 1 0 0 3 0 1 1 2 2 0 0 3 2 3 3 2 0 2 0 0

0 6 7 1 1 5 · 5 | 5 2 3 1 1 6 6 | 4 3 2 3 2 | 2 — — —

C G/B Am F C F D7/#F G

3 0 3 3 3 0 3 0 1 2 2 2 2 3 3 2 0 1 0 3 3 2 0 2 0 0

5 · 3 2 2 5 3 | 3 · 1 6 6 — | 0 5 1 3 4 3 2 | 2 — — —

F C/E Am7 Am7/G F Dm7 C/E F6 F/G F/C C

2 0 1 0 0 3 0 1 1 2 2 0 0 3 2 3 3 2 0 2 0 0

0 6 7 1 1 5 · 5 | 5 2 3 1 1 6 6 | 4 3 2 1 | 1 — — — :

F C/E Am7 Am7/G F Dm7 C/E F6 F/G F/C C

2 0 1 0 0 3 0 1 1 2 2 0 0 3 2 3 3 2 0 2 0 0

0 6 7 1 1 5 · 5 | 5 2 3 1 1 6 6 | 4 3 2 1 | 1 — — — ||



# 玫瑰玫瑰我愛你

演奏 / 董运昌 编曲 / 林慧哲



A

Key



A

Play



4/4, = 180

Tempo

A    
 F#m 2fr.    
 Dmaj7    
 Ds/E 7fr.    
 E    
 A 2fr.    
 A    
 Bm 7fr.    
 E

2 0 2 0 2 5 7 9 7 0 5 2 2 2 2 0 0 2 0 7 9 7 10 7 0 0  
 0 4 2 0 7 7 1 2 0 0 2 4 0 0 2 0 6 7 9 9 Harm. 7 0 2 4  
 1 2 3 5 6 i i 3 2 5 i — 1 1· 2 3 5 5 2 3 2 i 6 5 —

A    
 C#m 4fr.    
 F#m 2fr.    
 Bsus4 2fr.    
 E    
 A 5fr.    
 Amaj7/G#    
 F#7    
 C#m7-5/G    
 Bm 2fr.    
 E7    
 Amaj7    
 C#7/G#

2 0 5 2 5 2 2 5 2 5 2 0 6 5 7 5 0 7 0 2 4 2 0 3 2 4 2 0 3 2  
 0 2 4 6 2 4 4 2 4 2 0 4 2 0 7 6 5 4 2 2 4 0 0 0 4 4  
 1· 2 3 5 6 i i 6 6 5 6 i 3 2 — 3 5 6 i 5 6 5 3 2 3 5 4 3 2

A    
 Dmaj7 5fr.    
 D#7    
 E9 7fr.    
 E9 5fr.    
 A 2fr.    
 A    
 Bm 7fr.    
 E

2 0 2 0 2 5 9 7 5 5 2 2 2 2 0 0 2 0 7 9 7 10 7 0 0  
 0 4 2 0 5 6 7 6 0 0 2 4 0 0 2 0 6 7 9 9 Harm. 7 0 2 4  
 1 2 3 5 6 i i 3 2 5 i — 1 1· 2 3 5 5 2 3 2 i 6 5 5 —



1. 2 3 5 6 1 1 6 6 | 5 6 1 3 2 — | 3 5 6 1 5 6 5 3 | 2 3 5 4 3 2 |

1. 2 3 5 6 1 1 3 | 2 5 1 1 — | 1 7 6 2 | 0 7 7 6 5 1 |

2 3 5 5 1 2 3 | 5 6 3 — | 1 7 6 2 | 0 7 7 6 5 1 |

2 3 5 5 1 2 3 | 5 6 2 2 — | 1 1 2 3 5 5 | 2 3 2 1 6 5 5 — |

1. 2 3 5 6 1 1 6 | 5 6 1 3 2 — | 3 5 6 1 5 6 5 3 | 2 3 5 4 3 2 |







## 二、小调调弦法

### Open E minor

E B E G B E

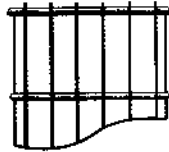

升高  
一个全音

升高  
一个全音

### Open D minor

D A D F A D

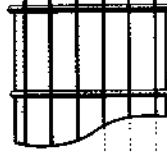

降低  
一个全音

降低  
一个全音

降低  
一个全音

降低  
一个全音

## 三、含有和弦外音的调弦法

当我们在开放弦上弹奏能够得到一个较好的「SENSE」时，可以使用此种带有和弦外音的调弦法。

### Open D sus4

D A D F A D

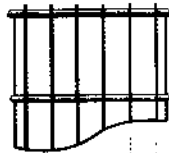

降低  
一个全音

降低  
一个全音

降低  
一个全音

降低  
一个全音



# 明天我要嫁给你

词/周华健 曲/周华健 演唱/周华健



Dm—F



Dm—F



4/4



Soul



EADGCE  
654321

F9



D9

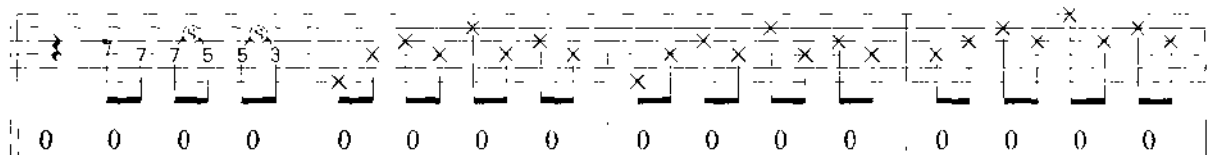

$\flat$ B



C

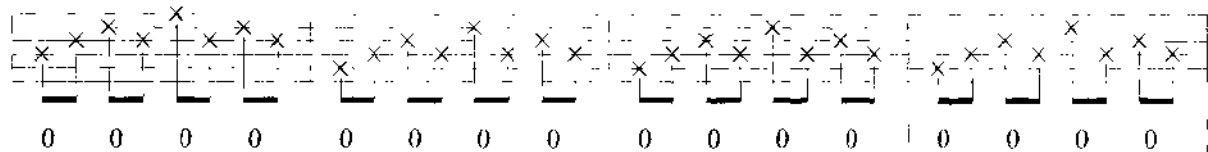

%

D9



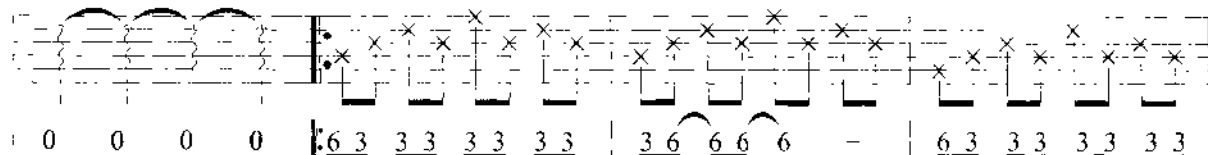

$\flat$ B



秒针 分针 滴答 滴答 在心 中 我的 眼光 闪烁 闪烁  
我问 自己 要你 爱你 有多 浓 我要 和你 双宿 双飞





弹指之间

**bB/B**  **C** 





3 6 6 6 6 - 6 3 3 3 3 3 3 3 3 6 6 6 6 6 5 - - -

好空 洞 我的心跳扑通扑通地阵阵悸动  
多冲 动 我的内心忽上忽下地阵阵悸动

**C**  1. **C**  2. **F9** 





5 - - - | 4 5 5 - 3 5 5 5 5 3 5 5 - - -

呜 明天我要嫁给你啦

**Am**  **D**  **bB**  **bB/B** 





3 5 5 5 5 3 2 1 1 - 0 5 5 5 6 1 1 1 6 6 6 6 3 3 3 1 6 3 2

明天我要嫁给你啦 要不是 每天的交通 烦扰着我所有的梦  
要 停 电那 一天 才 发现 我 寂寞 空洞

**G**  **C**  **F9**  **F9** 

2 - - - 2 - - - 3 5 5 5 5 3 3 5 5 - - -

明天我要嫁给你啦

**Am**  **D**  **bB**  **bB/B** 

3 5 5 5 5 3 2 1 1 - 0 5 5 5 6 1 1 1 5 5 5 6 1 1 1 5 5 5

明天我要嫁给你啦 要不是 你 问我 要不是 你 劝我 要不是





Chord diagrams:  $\flat B$ , C, F9

6 1 1 5 3 2 1 1 1 7 7 - 7 1 1 - - - 1 - 3 -

适当 的时候 你 让我 心 动

Chord diagrams: F9, D (2fr.), D9 (5fr.)

6 - - - 6 - 6 7 6 3 - - - 3 - - 3 5

Chord diagrams:  $\flat B$ ,  $\flat B/B$ , C

5 1 - - 6 - 3 3 2 - - - 2 - - - 3 2 0 3 0

Chord diagrams: F (3fr.), F-5 (3fr.), Fsus4 (3fr.)

1 0 0 0 0 0 0 0

动

Fine



# Longer

TOYOTA汽车电视广告主题曲

Dan Fogelberg



G	Am7	Bm11	C9	G	Am7	Bm11	C
0	0	0	0	0	0	0	0

G	Am7	Bm11	C9	Bm11	A69	G
3	1 2	3	4	5	4	3

G	Am7	Bm11	C9	G	Am7	Bm11	C9
0	5 3 2 2	3 4	5 6 5 3 1 1 2 2	0	5 3 2 2	3 4	5 6 7 6 6

Longer than there've been finishes in the ocean

Higher than any

bird ever flew



G Am7 Bm11 C9  $\flat$ B11 A69 G

0 5 3 2 2 3 4 5 6 5 3 1 1 2 2 5 4  $\flat$ 3 4 4 2 1 1

Longer than there've been stars up in the heaven I've been in love with you

G Am7 Bm11 C9 G Am7 Bm11 C9

0 5 3 2 2 3 4 5 6 5 1 1 2 2 0 5 3 2 2 3 4 5 6 7 6 6

stronger than any mountain cathedral Truer than any tree ever grew

G Am7 Bm11 C9  $\flat$ B11 A69 G

0 5 3 2 2 3 4 5 6 5 1 1 2 2 5 4  $\flat$ 3 4 4 2 1 1

Deeper than any forest primeval I am in love with you

C6 C  $\flat$ B6  $\flat$ B C6 C  $\flat$ B6  $\flat$ B

$\flat$ 7 6 4 5  $\flat$ 6  $\flat$ 7 5  $\flat$ 3  $\flat$ 3  $\flat$ 7 6 5 5 4  $\flat$ 6 5 4  $\flat$ 3

I'll bring fire in the water You'll send showers in the springs

C6 C  $\flat$ B6  $\flat$ B Gsus4 Gsus4/ $\sharp$  Gsus4/F Gsus4/ $\sharp$

$\flat$ 7 6 4 5 6 7 5  $\flat$ 3  $\flat$ 3 5 5 0 4 3 2 2

We'll fly through the falls and summers with love on our wings



G Am7 Bm11 C9 G Am7 Bm11 C9

0 5 3 2 2 3 4 5 6 0 5 3 1 2 2 0 5 3 2 2 3 4 5 6 7 7 6 6 0 5 5

through the years as the fire starts to yellow Burning lines in the book of our loves Through the

G Am7 Bm11 C9 bB11 A69 G

5 3 2 2 0 3 4 5 5 6 0 5 3 1 2 2 5 4 b3 4 4 2 1 1

binding cracks and the pages starts to yellow I'll be in love with you

bB11 A69 G C6 C bB6 bB

5 4 b3 4 4 7 1 1 0 2 3 4 5 3 1 5 0 1 2 b3 4 2 b7 4

I'll be in love with you (G调转C调)

C6 C bB6 bB C6 C bB6 bB

0 2 3 4 5 3 1 5 0 1 2 b3 4 2 b7 4 0 2 3 4 5 3 1 5 0 1 2 b3 2 1 2 4 b7 1

Gsus4 Gsus4/F Gsus4/F Gsus4/F

5 0 0 0 5 6 5 4 3 2

(C调转G调) %



G                      ♭B11      A69                      G                      ♭B11      A69

1 — — — — — 5 4 ♭3 4 4 7 1 1 — — — — — 0 0 0 0

I'll be in love with you

G

0 0 0 0

Fine



### 属七和弦琶音练习 G7

2 1 4 1 3 2 1 1 1 2 3 1 4 1 2

3 2 5 3 5 4 3 3 4 5 3 5 2 3

和弦根音

注：1 2 3 4 表手指代号。可依次选择任意琴格来作练习

# 55 Slide/Bottleneck

## Guitar

在 Blues 的演奏形态中，常常使用这种叫做 Bottleneck（小圆管）的 Slide 演奏法。一般我们也称 Slide 为 Bottleneck 的一种奏法，事实上，两者是一样的。在 Slide 时，通常会使用像水管般的小铁管，下图中，我们便是使用市面上所贩售的 Slide 圆管做练习。首先，将圆管套住左手手指，至于使用那一指都没关系，一般较常使用无名指或小指。好！如果你是使用无名指弹奏，便可使用中指与小指轻轻地夹住，以防圆管滑动。

### 一、技巧如图

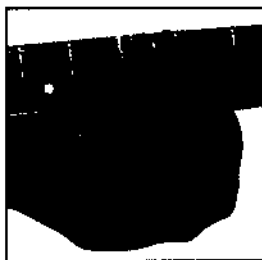

1. 将铁管轻轻地压在弦上，注意，切勿将弦压缩。

2. 弹奏的音程与琴格内的音是一样的。例如：第三弦第五琴格内的音是 Do，弹奏时将铁管轻压住第五格琴弦正上方即可。



3. 注意，Slide 铁管除了要压在琴弦正上方之外，还要与琴弦平行。

4. 一边弹奏时，使用铁管上方的手指将弦 Mute（消音）。



好！现在就让我们试着使用 Slide 弹奏三种和弦，千万注意弹奏时勿使 Slide 铁管呈斜面，或是离开琴弦的上方。

### ▶ 范例一

Three guitar tablature systems illustrating slide techniques:

- System 1: B string slide from fret 9 to 14.
- System 2: A string slide from fret 14 to 14, B string slide from fret 14 to 14.
- System 3: B string slide from fret 4 to 2, A string slide from fret 4 to 4.

## 二、使用Open Tunning的作法

在 Slide 中使用 Open Tunning 的做法也经常被使用。

### 1 • Open E Tunning

这种弹奏方式虽然和弦指型不一样，但是，使用 Slide 后就变得容易了！右图是经过 Tuning 之后，各弦的音程变化了。

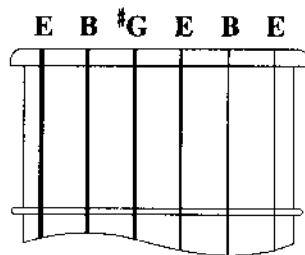





# Dear

词/姚谦 曲/颜志琳 演唱/吕方、颜志琳、袁惟仁



A



A



4/4 ♩ = 91



Soul

A Aadd9 #Fmadd9/#C

3 2 2 5 5 3 3 3 6 1 2 2 1 1 6 6

(1st Guitar Arp.)

A Aadd9 #Fm7

3 2 2 5 5 3 3 6 1 2 5 5 1 1 1

A Bm7sus4

3 2 2 1 1 5 5 3 2 2 6 6 6



(Guitar 1)

3 2 2 1 1 5 5 3 2 2 6 6 6

(Guitar 2 Slide)

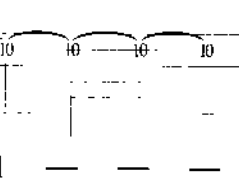
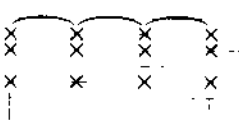
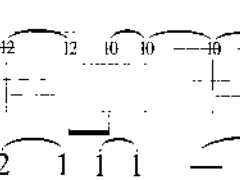
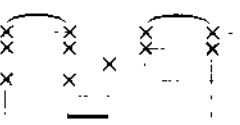
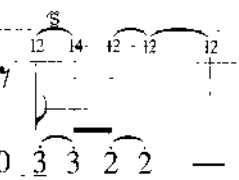
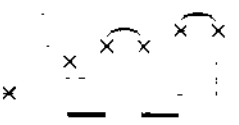
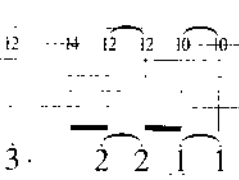
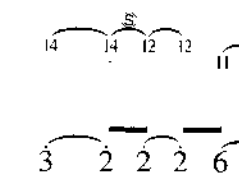
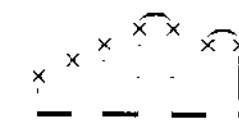
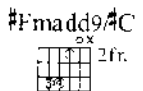
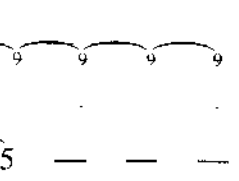
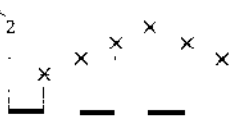
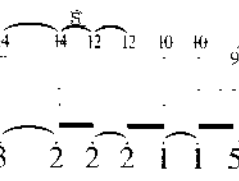
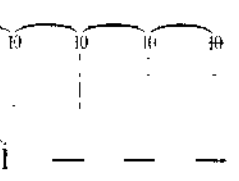
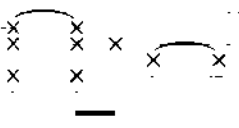
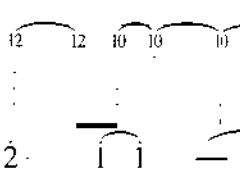
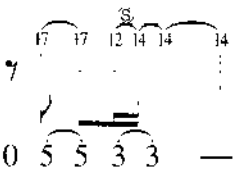
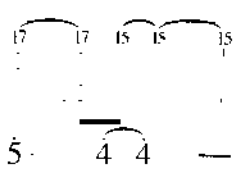
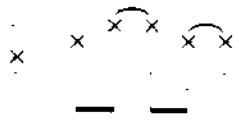







A  Bmsus2  2fr.



0 3 2 3 2 1 2 1 1 0 1 2 3 4 4 4 0 4 4 3 3 2 2 0 2 2 3

想念像 一个 盒子 不管外 面发生 什么 事 谁都无

D  Dadd9  A  A 



4 4 4 4 5 0 1 4 4 4 4 1 2 1 2 3 3 3 — 0 0 0 0

法 看透干 涉 里 面我波 涛 又汹涌 的 心事

A  Bmsus2  2fr.





0 3 2 3 2 1 2 1 1 0 5 2 3 4 4 4 4 4 4 3 3 2 2 0 5 2 3

时光只 能够 猜测 她离开 后孤单 怎么 解释 沉默只

D  D/E  A 

4 4 4 4 4 5 0 5 4 4 4 4 3 2 2 1 — — 0 0 0 5 5

是 一个开 始 等 待永 远不 可能 结 束 DEAR

Aadd9  2fr. Aadd9#G  2fr. #Fm7  2fr. #Fm7/E 

6 5 5 5 3 3 5 6 5 5 3 2 2 1 1 — — 0 0 6 6

我心依 然这 样 唤她 的名 字 别 人



D D/F Bm7 E

4 3 4 4 3 3 4 4 3 4 4 3 3 4 4 5 3 2 1 1 2 2 — — 5 5

只能经过却走不进我的心深处 DEAR

Aadd9 Aadd9#G #Fm7 #Fm7/E

6 5 5 5 3 3 5 6 5 5 3 2 2 1 1 — — 0 0 6 6

是我梦里会称呼她的方式 别人

D D/F Bm7 E

4 3 4 4 3 3 4 3 4 4 3 3 4 5 3 2 1 1 2 2 — 3 2 2

永远不能取代她在我心里位置 Dear Forever

Asus4 A A

2 1 1 — — 0 0 0 0 3 2 2 1 1 5 5 — —

(Slide GT.同前奏)

Bm7sus4 D E

3 2 2 6 6 6 — — — 5 4 4 — 0 5 5 3 3 —



Asus4                      A                      Aadd9                      Aadd9

2. 1 1 — 1 — — | 3 2 2 2 1 1 5 5 — —

#Fmadd9/C                      Dadd9                      E

3 2 2 2 6 6 | 6 — — — 3. 2 2 1 1 0 3 3 2 2 —

Asus4                      A                      Gadd9                      2.

2 1 1 1 — 1 — — :|| 0 4 3 4 3 2 | 3 2 2 — 2 3

爱是清醒的 迷失 所以

Dadd9                      E

4 4 4 4 4 4 4 — 6 5 5 — — — 5 — 0 5 5

可能不会 终止 DEAR %



D                      Bm                      E

4 3 4 4 3 3 4 3 4 4 3 3 4 5 3 2 1 1 2 2 0 5 3 3 2

永远不能 取代她在 我心里位置 I want you ba-







**A**

2 1 1 — — 0 0 0 0 3 2 2 6 6 6 — — — —



-by (2nd Slide GT. 同前奏)

**D** **E** **Asus4** **A**





5 4 4 — 0 5 5 3 3 — 2 1 1 — 1 — — —

**A** **Aadd9** **#Fmadd9/#C**

3 2 2 2 1 1 5 5 — — — 3 2 2 2 6 6 6 — — —

**D** **E** **Aadd9** **Asus4** **A**

3 2 2 — 0 2 3 — 2 1 1 1 — 1 — — — 0 0 0 0

Rit..... **Fine**



# 56 音乐类型【九】

## 十二小节式的 蓝调伴奏模式

在一个基本蓝调音乐的和弦进行模式中，使用三种最主要的和弦（I级、IV级、V级），而形成一个重要的和弦进行（Chord Progressions）模式，这将会是一个非常重​​要的观念。了解了这个法则之后，可以让你听得懂蓝调音乐，进而成为 Crossroad 中的「Blues man」。在这里我们将这个法则称之为「基本的12小节蓝调进行模式」。

### 一、基本12小节的进行模式

#### A大调

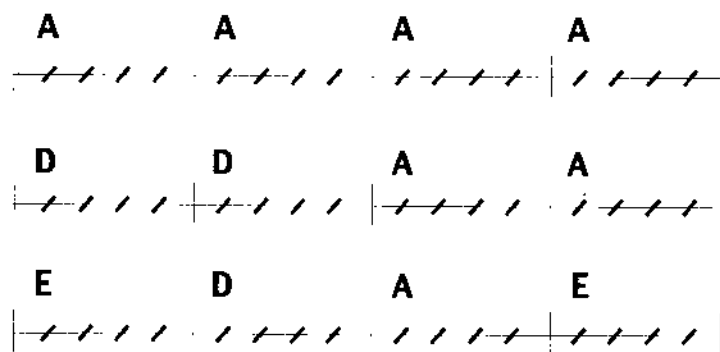

#### Bm小调

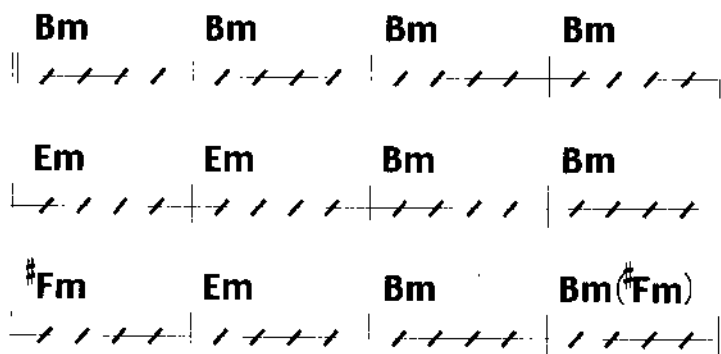

## 二、加入七和弦的进行模式

**E7**      **E7**      **E7**      **E7**  
 / / / / / | / / / / / | / / / / / | / / / / / |

**A7**      **A7**      **E7**      **E7**  
 / / / / / | / / / / / | / / / / / | / / / / / |

**B7**      **A7**      **E7**      **A7**  
 / / / / / | / / / / / | / / / / / | / / / / / |

## 三、A蓝调进行模式

**A**      **A**      **A**      **A**

**D**      **D**      **A**      **A**

**E**      **D**      **A**      **E**





# 57 蓝调音阶

蓝调音阶与小调五声音阶，几乎具有相同的音程组合。惟一差别的地方是蓝调音阶比小调五声音阶（A, C, D, E, G）多了一个降五度音程，使得蓝调音阶的音程音成了 A（根音），C（3度），D（4度）， $\flat E$ （ $\flat 5$ 度），E（5度），G（ $\flat 7$ 度），由于增加了降五度音程的 $\flat 3$ 音，使得整个音阶的蓝调味十足，所以我们就称此音为“蓝调音”。以下笔者列出了 A 调蓝调音阶的五种指型，就像之前练过的自然大调的指型一样，你不仅要会每一种指型，其次要练习 2 种或 2 种以上的指型连结。

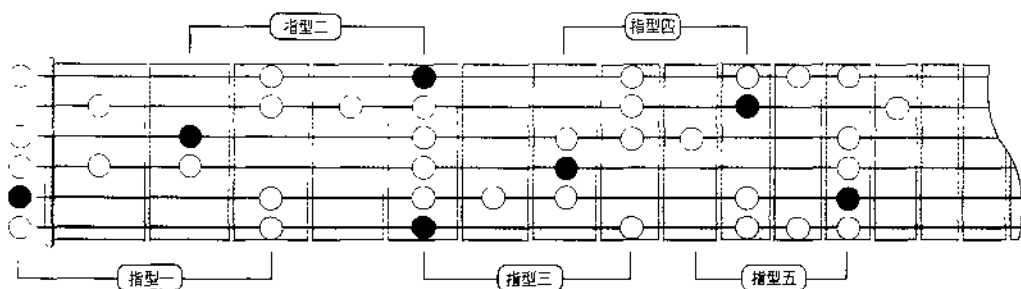

在实际演奏的时候，除了以上的音阶指型外，我们也常常听到一些是属于音阶以外的音，如大二度音程、大三度音程、大六度音程……等等，这些音都算是可弹奏的音，只是把它当做是经过音来处理，换句话说，你可以在 2 个任意的全音中加入其半音当做经过音来使用。再者这些指型音阶是可以在指板上任意的移动，而得到别的调性。譬如说，如果你要弹奏 D Blues，那您可以试着计算 A 到 D 之间的音程距离，A 到 D 是完全四度，半音数为 5，所以在琴格上将 A 蓝调音阶整个往下移动 5 个琴格，就可得到 D 蓝调阶了。

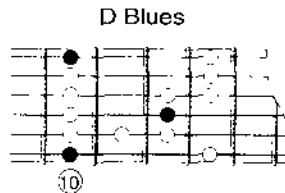
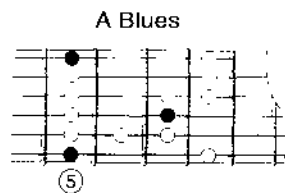

# 58 琴弦整平

## Guitar

如果你的吉他会发出吱吱的杂声时，多半都是因为琴弦的不平整所造成的。在这里我们将告诉你如何消除吉他杂声，我们称之为「琴弦整平」(Leveling Frets)。整平时请先调整钢管使琴头变直。

### 一、调整钢管

一般来说，吉他在经过气候的变化及弦的拉力，在使用过一段时间会有变形的可能，尤其是在琴颈的地方。这时候琴颈内的钢管就显得非常重要了。一般来说如果吉他等级不是太低，都会在琴颈内装一支钢管，用来调整琴颈的弯曲直度。

调整时请先将吉他立起，用眼睛检视琴颈侧边的弯曲情况，一般来说，如因琴颈成右图的弯曲方式，则请使用六角扳手顺时针转动，可让琴颈成凸状，反之，则可以让琴颈成凹状，但须特别小心一点，钢管是由一螺帽来控制，旋转时请特别控制力道大小，别让螺帽脱牙了。

### 二、整平琴弦

使用工具：15cm钢尺或绝对平直的物体、细砂纸。

首先，请先将吉他弦全部放松，使用干布先将琴颈清洁一番，然后使用钢尺平直的侧面靠在吉他琴颈上，使用目视法，看看每一个琴弦的高低状况。在此，为了求目视的准确度，请将吉他拿起对准日光灯或光线较强的地方，将更容易看清楚每一琴弦的状况。

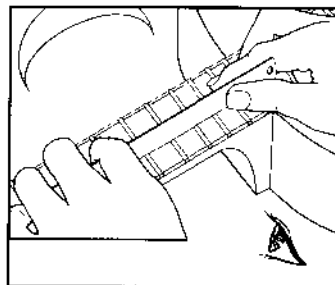

一般来说，不平整的琴弦便是造成吉他打弦或杂音的主因，所以这时候请拿起砂纸，在逐一检视的时候，也逐一地来做琴弦整平工作，但是请注意，任何吉他的指板都有一特定的弧度，所以请顺着这个弧度来做整平的工作。

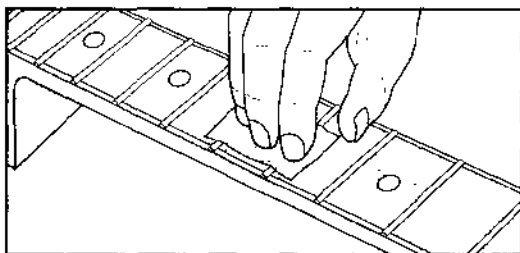

这时，琴弦也可能会因为过度的整平而使得吉他的延音效果变弱，声音变得迟钝，所以在整平时也须特别小心，切勿将琴弦磨成一个大平面，尽量以适度的整平为原则。

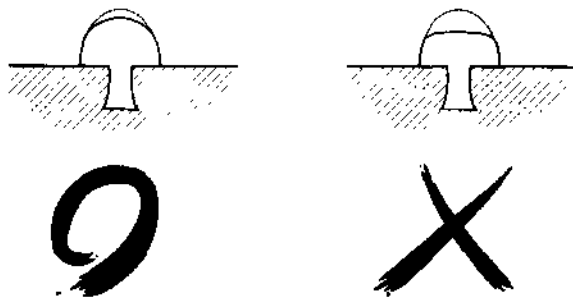

如此，逐一检视，逐一整平，直到琴弦间的高度落差为最小，再将弦装上就可以了。



# 59 各级和弦图表

## C Major - A Minor

C Dm Em F G Am Bdim Cmaj7 Dm7 Em7 Fmaj7 G7 Am7 Bm7b5/D Bdim7/D

## G Major - E Minor

Gmaj7 Bm D F#dim Bm7 D7 F#m7b5/E F#dim7/Eb

## D Major - B Minor

Dmaj7 F#m A C#dim F#m7 A7 C#m7b5/E C#dim7/E

## A Major - F# Minor

Amaj7 C#m E G#dim C#m7 E7 G#m7b5/D

## E Major - C# Minor

Ema7 G#m B D#dim G#m7 B7 D#m7b5

## F Major - D Minor

Fm Bb C7 Edim Gm7 Bbmaj7 Em7b5

0	E	A	D	G	B	E
F	A#	D#	G#	C#	F#	
F#	B	E	A	C#	F#	
G	C#	F#	A#	D#	G#	
G#	C#	F#	B	D#	G#	
5	A	D	G	C	E	A
A#	D#	G#	C#	F#	A#	
7	B	E	A	D	F#	B
C	F	A#	D#	G#	C	
9	C#	F#	B	E	G#	C#
D	G	C	F	A	D	
D#	G#	C#	F#	A#	D#	
12	E	A	D	G	B	E

使用根音在  
第6弦的  
封闭和弦

Maj7 7 Maj7 minor m7 m7b5 dlm7

Maj6 m6 Maj9 m9 9 7+ 7b5 7+9 7b9 7sus 13 13b9 mMaj7 +Maj7

使用根音在  
第5弦的  
封闭和弦

Maj7 7 Maj7 minor m7 m7b5 dlm7

Maj6 m6 Maj9 m9 9 7+ 7b5 7+9 7b9 7sus 13 13b9 mMaj7 +Maj7

使用根音在  
第4弦的  
封闭和弦

Maj7 7 Maj7 minor m7 m7b5 dim7

Maj6 m6 Maj9 m9 9 7+ 7b5 7+9 7b9 7sus 13 13b9 mMaj7 +Maj7



# 60 Guitar 各调音阶图解

**C major - A minor**

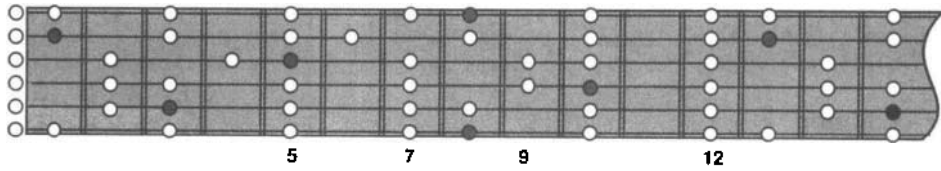

**G major - E minor**

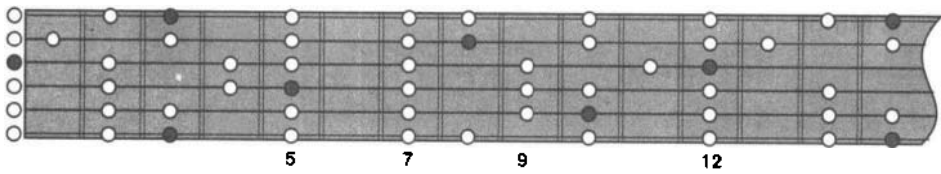

**D major - B minor**

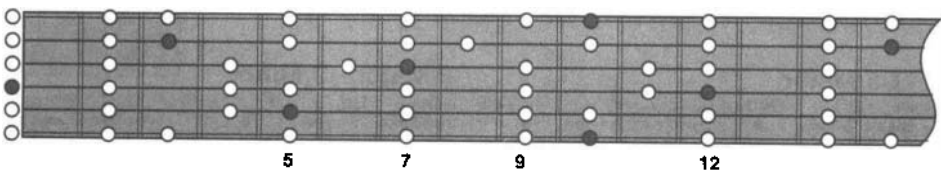

**A major - F# minor**

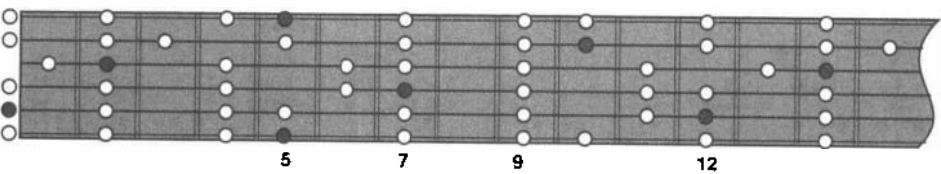

**E major - C# minor**

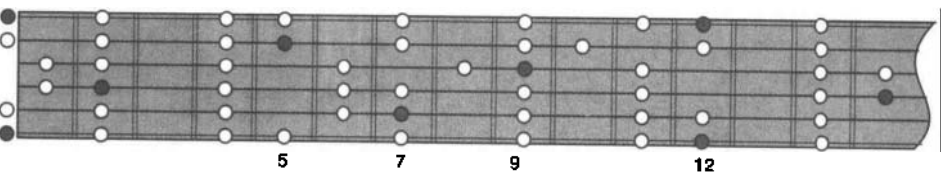

**F major - D minor**

